

ADVANTAGE[®] 4000

Series APR

AIR-PURIFYING RESPIRATOR

Model 4100 SINGLE-PORT Full Facepiece Respirator
P100 Respirator
GME - P100 Respirator

RESPIRATOR APPLICATION

P100 Respirator
GME-P100 Respirator

INDUSTRIAL APPLICATION

Chin-Type Canister

Model 4200 TWIN-PORT Full Facepiece Respirator
P100 Respirator
GME - P100 Respirator

RESPIRATOR APPLICATION

P100 Respirator
GME-P100 Respirator

INDUSTRIAL APPLICATION

Advantage 4200 Respirator

OPERATION AND INSTRUCTIONS

⚠ WARNING

This manual must be carefully read and followed by all persons who have, or will have, the responsibility for using or servicing the Advantage 4000 Air-Purifying Respirator. The Advantage 4000 Air-Purifying Respirator will perform as designed only if used and serviced according to these instructions; otherwise, the respirator could fail to perform as designed, and persons who rely on the Advantage 4000 Air-Purifying Respirator could sustain serious personal injury or death.

The warranties made by MSA with respect to the product are voided if the product is not installed, used and serviced in accordance with the instructions in this manual. Please protect yourself and your employees by following the instructions. Please read and observe the WARNINGS and CAUTIONS inside. For any additional information relative to use or repair call 1-800-MSA-2222 during regular working hours.

See separate insert for NIOSH Approval Information: P/N 10084702

For More Information, call 1-800-MSA-2222 or Visit Our Website at www.MSAafety.com



MINE SAFETY APPLIANCES COMPANY
CRANBERRY TWP., PENNSYLVANIA, U.S.A. 16066

INTRODUCTION

TABLE OF CONTENTS

Instructions for Use and Care.....	3	Maintaining the Respirator.....	15
General Description	5	Removing the Respirator	21
Size Selection.....	9	Decontamination	21
Respirator Fit Test.....	9	Cleaning and Disinfecting	23
Preparing the Respirator for Use	11	Storage.....	25
Donning.....	13	Advantage Facepiece Assemblies.....	28
Negative Pressure Seal Test	14		

CAUTIONS AND LIMITATIONS

Advantage 4000 Industrial and Gas Mask Applications

Note: All cautions and limitations do not apply to all applications. Refer to the NIOSH approval insert to verify the applicable cautions and limitations.

- A- Not for use in atmospheres containing less than 19.5 percent oxygen.
- B- Not for use in atmospheres immediately dangerous to life or health.
- C- Do not exceed maximum use concentrations established by regulatory standards.
- H- Follow established cartridge and canister change out schedules or observe ESLI to ensure that cartridges and canisters are replaced before breakthrough occurs.
- I- Contains electrical parts that may cause an ignition in flammable or explosive atmospheres.
- J- Failure to properly use and maintain this product could result in injury or death.
- L- Follow the manufacturer's User's Instructions for changing canisters.
- M- All approved respirators shall be selected, fitted, used, and maintained in accordance with MSHA, OSHA and other applicable regulations.
- N- Never substitute, modify, add, or omit parts. Use only exact replacement parts in the configuration as specified by the manufacturer.
- O- Refer to User's Instructions, and/or maintenance manuals for information on use and maintenance of these respirators.
- P- NIOSH does not evaluate respirators for use as surgical masks.
- S- Special or critical User's Instructions and/or specific use limitations apply. Refer to User's Instructions before donning.
- BB- Not for use for entry into atmospheres immediately dangerous to life and health.
- CC- For entry, do not exceed maximum use concentrations established by regulatory standards.
- FF- Respirators are to be fit tested prior to use with the heaviest cartridges, canisters, filters and/or accessories intended to be used. Fit testing should also be

conducted while wearing all personal protective equipment intended to be used. See User's Instructions for fit test requirements.

S- SPECIAL OR CRITICAL USER'S INSTRUCTIONS

Mersorb-P100 cartridges can be used against a mixture of chlorine and mercury that are both present simultaneously, but cannot be used if alternating between mercury contaminated atmospheres and chlorine-contaminated atmospheres.

Mersorb-P100 respirators utilize an end-of-service-life indicator for use against metallic mercury vapor. The band around the side of each Mersorb-P100 cartridge consists of chemically-treated paper. In use, as the paper is exposed to metallic mercury vapor it changes from orange to brown. When the indicator color changes to brown, the cartridge is beginning to lose its effectiveness against metallic mercury vapor and must be replaced. Thus, the wearer has a constant, positive check on the condition of the cartridge.

Do not enter any atmospheres with this respirator unless you know that you are not colorblind and can distinguish between the beginning and ending colors of the end-of-service-life indicator (when using Mersorb-P100/Mersorb respirators only).

Special Instructions for P100 with Splash Guard:

1. Test for Tightness – Support the cartridge from behind using your fingers and depress the button with your thumb. Gently inhale so that the facepiece collapses slightly and hold breath for ten seconds. The facepiece will remain collapsed while the breath is held, unless there is a leak in the seal.

NOTE: If a leak is detected, adjust the straps or reposition the facepiece, ensure the push button is completely depressed, and repeat test until no leakage is detected.

INSTRUCTIONS FOR USE AND CARE

⚠ WARNING

1. An adequate respiratory protection program must include knowledge of hazards, hazard assessment, selection of proper respiratory protective equipment, instruction and training in the use of equipment, inspection and maintenance of equipment, and medical surveillance.
2. This respirator will perform as designed only if used and maintained according to the manufacturer's instructions. The Program Administrator and the users must read and understand these instructions before using or servicing this product.
3. If the respirator does not perform as specified in this manual, it must not be used until it has been checked by authorized personnel.
4. Do not alter, modify, or substitute any components.
5. Inspect the respirator regularly and maintain it according to the instructions. Repairs must only be made by properly trained personnel.
6. This respiratory protective device does not supply oxygen. Use only in adequately ventilated areas which conform to the appropriate standard.
7. This respirator must be used in conjunction with the proper chemical or particulate canister/cartridge(s) for protection against specific contaminants. If you cannot determine that the filter canister/ cartridge(s) used with this device is designed for the contaminant, or if you do not know the identity of the contaminant, do not use this device.
8. Do not use when concentrations of contaminants are unknown.
9. Do not use when appropriate exposure limit (PEL, REL, TLV, etc.) is not known.
10. Leave the contaminated area immediately if:
 - a. Breathing becomes difficult
 - b. Dizziness or other distress occurs
 - c. You taste or smell the contaminant
 - d. You experience nose or throat irritation
 - e. Instructed by responsible individuals
11. Use strictly according to the instructions, labels, and limitations pertaining to this device. Follow an established canister/cartridge(s) change-out schedule.
12. This respirator may not provide a satisfactory seal with certain facial characteristics, such as beards or large sideburns, that prevents direct contact between the skin and the sealing surface of the facepiece. Do not use this facepiece if such conditions exist.
13. Do not wear eyeglasses under the facepiece. The temples or sidebars on eyeglasses will prevent an air-tight seal. If you must wear glasses, install the spectacle kit.
14. The user must perform a respirator fit test (Quantitative Test or Qualitative Test) and follow all warnings and limitations specified.
15. Wear impermeable protective clothing to prevent exposure to gases and vapors which can poison by

skin absorption.

16. Do not use this full facepiece with self-contained breathing apparatus (SCBA) unless equipped with a push-to-connect inlet.
17. Do not use this respiratory protective device in explosive atmospheres.
18. Do not use for urethane paints or other paints containing isocyanates unless an appropriate cartridge change-out schedule is developed. Due to their poor warning properties, overexposure can occur without user awareness and result in severe permanent damage to the respiratory system. If unable to develop an appropriate change-out schedule, use an air-supplied respirator or SCBA.

Failure to follow all warnings, instructions, and established protective measures can result in serious personal injury or death.

⚠ WARNING

- This respirator/filter provides **LIMITED** protection. It may help reduce exposure to airborne biological agents, including H1N1 (swine) flu virus, avian (bird) flu virus, other types of influenza, SARS, or other bacterial or viral biological agents and help reduce the risk for influenza infection during a pandemic, but will **NOT** eliminate the risk of exposure, infection, illness, or death.
- This respirator/filter is certified by NIOSH to comply with the requirements specified for the designated filter efficiency level; however, appropriate authorities have **NOT** established a safe level of exposure to biological agents. Therefore, the respirator may **NOT** prevent transmission of influenza virus.
- Refer to the Centers for Disease Control and Prevention (CDC) at www.cdc.gov for guidance on the use of respirators to help decrease exposure to H1N1 virus or other airborne biological agents in community, home, and occupational settings. The CDC recommends fit testing, medical evaluations, and training for optimal effectiveness when a respirator is used in a non-occupational setting. Neglecting these preparatory measures may cause an unsafe condition. Respirators used in an occupational setting **MUST** be used in accordance with a complete respiratory protection program as required by OSHA, which includes proper selection, training, fit-testing, and fit-checking. Detailed information on a respiratory protection program is available by contacting OSHA or visiting www.osha.gov.
- Do **NOT** remove respirator in contaminated areas. The outer surface of the respirator **MUST** be treated as if it is contaminated at all times. Tight-fitting

INSTRUCTIONS FOR USE AND CARE

safety goggles, or a full-facepiece respirator, may further help prevent transmission of influenza virus.

- The CDC recommends frequent hand washing and wearing gloves to help prevent transmission of disease due to exposure to surfaces where contaminants may be present, and also immediately following removal of the respirator.
- Do NOT reuse or share maintenance-free respirators. ALWAYS clean cartridge-style respirators before reuse in accordance with the instructions provided.
- This respirator/filter is NOT for use by (a) children, or (b) people with a medical condition that may be adversely affected by using it.

Failure to follow all warnings and instructions can result in serious personal injury or death.

CAUTION

When using filters in an application that produces sparks, ensure that they are protected by a shield. Contact with sparks can damage filters and reduce protection.

WARNING

- DO NOT use a gas mask chin canister in an area where spark is present.
- DO NOT use an OptiFilter® XL in an area where spark is present.

Failure to follow this warning can result in serious personal injury or death.

GENERAL DESCRIPTION

The Advantage 4000 APR is an air purifying respirator intended for use in atmospheres which are not immediately dangerous to life or health (non-IDLH). This respirator is intended for applications which may require the user to enter or exit a hazardous area, or work within the area for a limited time. Advantage 4000 series APRs are not approved for use in atmospheres containing CBRN contaminants.

The Advantage 4000 Model 4100 consist of a faceblank mask and head-harness with push-to-connect inlet assembly, twin-cartridge inlet assembly, or RD40 inlet assembly.

The Advantage 4000 APR Model 4200 consist of a full-facepiece mask with twin-port or plugged inlet assembly. Use of noseclip assemblies provided with Advantage 4000 series APRs is not optional. Properly installed noseclip assemblies must be present during use. Primary faceblanks and head-harnesses are Hycar™ and cloth, respectively.

METHOD OF OPERATION

Inhaled air is drawn through the canister/cartridge(s) which contain(s) adsorbents and a filter that removes or neutralizes specific contaminants. Exhaled air leaves the facepiece through the exhalation valve.

It is important that the user become familiar with the application and operation of the Advantage 4000 series APR Respirator and ensures that it fits properly before use.

When properly fitted to the user, the Advantage 4000 full facepiece with noseclip, head harness, and inlet assembly combined with the appropriate canister/cartridge(s), becomes a complete respiratory protective device.

The respirator consists of the following subassemblies:

- full facepiece (with required noseclip assembly)
- head harness
- inlet assembly
- filter canister/cartridge(s)

Facepiece size is identified on the front of the facepiece on the lower left head harness tab.

Noseclip size is identified on the front of the noseclip on the lower left (user's left) side of the baffle.

Note: Facepiece and noseclip size should match.

▲ WARNING

Advantage 4000 series APRs are not approved for use in atmospheres containing CBRN contaminants. Contact MSA at 1-800- MSA-2222 for information regarding CBRN approved facepieces. Failure to fol-

low this warning can result in serious personal injury or death.

FILTER(S) / CARTRIDGE(S)

See separate insert for NIOSH Approval Information (P/N 10084702).

ATTACHING FILTER CARTRIDGE

Model 4200 Twin-Port Respirator or Model 4100 Faceblank with Twin-Cartridge Inlet Assembly

1. Carefully attach filter cartridges to facepiece connectors (bayonets).
 - a. Align the small lug on the connector with the match-mark on the cartridge body to mate the cartridge cutouts with the bayonet lugs.



- b. Turn the cartridge clockwise until tight.

- c. (see Replacing Cartridges).

Model 4100 Single-Port Faceblank with RD40 Inlet Assembly.

1. Thread the cartridge into receptacle.
2. Hand tighten slowly until snug to ensure a good seal and prevent damage to threads.

Attaching Snap-On Filters

1. Place a filter in each filter cover. Never load filters into receptacles.



GENERAL DESCRIPTION

2. Snap filter cover onto both cartridges taking care not to damage the filter.



Note: If using the Comfo/Advantage Adapter, follow the instructions supplied in the Comfo/Advantage kit.

RESPIRATOR USE LIMITATIONS

The wearer must comply with the following MSA respirator use limitations:

- A. **MAXIMUM USE CONCENTRATION** – Do not exceed any of the following:
 1. Routine Use –
 - a. 50 times the exposure limit for the contaminants present if using a quantitative fit test method. Using a qualitative fit test may reduce the maximum use concentration. See the Respirator Fit Test section.
 - b. Immediately Dangerous to Life or Health (IDLH) concentration for any contaminant present.
 2. Escape (for Gas Mask only) –
- B. The limitations outlined in the applicable NIOSH approval
- C. Any applicable limitation contained in a standard established by regulatory agency (such as OSHA) with jurisdiction over the wearer.

⚠ WARNING

An appropriate cartridge change-out schedule must be developed by a qualified professional unless the cartridge/canister uses an end-of-service-life indicator. The change-out schedule must take into account all factors that may influence respiratory protection including specific work practices and other conditions unique to the workers' environment. If using against substances having poor warning properties there is no secondary means of knowing when to replace the cartridge/ canister. In such cases, take appropriate additional precautions such as a more conservative change-out schedule or use of an air-supplied respirator or SCBA to prevent overexposure. Failure to follow this warning can result in serious personal injury or death.

The following is a partial list of substances with poor warning properties:

Acrolein	Ozone
Carbon monoxide	Phosgene
Hydrogen selenide	Phosphine
Aniline	Phosphorous trichloride
Diisocyanates	Stibine
Methanol	Sulfur chloride
Arsine	Urethane or other
Dimethyl sulfate	diisocyanate containing
Methyl bromide	paints
Bromine	Vinyl chloride
Hydrogen cyanide	Nitro compounds:
Methyl chloride	Nitrogen oxides
Methylene chloride	Nitroglycerin
Nickel carbonyl	Nitromethane
Nitric Acid	

Canister for Chin-Type Gas Masks (Model 4100 Single Port)

Part No.	MSA Canister Identification	Purifying Protection Code	Approval	Maximum Escape Conditions		Gas/Vapors
				% Volume	PPM	
10059903	Phosphine/ Ammonia/Chlorine/ P100	PH/AM/CL TC	TC-14G-0274	0.50% 0.15%	1500	Ammonia/Chlorine Phosphine
10067469	Organic Vapor/ P100	OV	TC-14F-0279	0.50%	5000	Organic Vapors
10067491	Hydrogen Fluoride/P100	HF	TC-14G-0280	0.10%	1000	Hydrogen Fluoride
10067470	Formaldehyde Acid Gas/Chlorine Dioxide/Escape from Hydrogen Sulfide/P100	FM/AG/CD/HS	TC-14G-0282	0.05% 0.50% 0.10%	500 5000 1000	Formaldehyde Acid Gases and Hydrogen Sulfide Chlorine Dioxide

GENERAL DESCRIPTION

- D. MIXTURES OF CONTAMINANTS – This gas mask can be used for protection against a mixture of contaminants that are present simultaneously or alternately against one contaminant then another (using the same canister) if the mixture meets the following conditions:
1. The canister must be approved for all contaminants present.
 2. NIOSH permits mixing of the following contaminants: organic vapors, chlorine, chlorine dioxide, hydrogen sulfide, acid gases, ammonia, and carbon monoxide.
 3. Particulates can be mixed with any other particulate or any gas or vapor for which the canister is approved.
 4. Contaminants present simultaneously must be below IDLH levels for the specific contaminants. If any one contaminant in the mixture exceeds the IDLH concentration, then the entire mixture must be treated as IDLH and the respirator cannot be used (except for escape when using respirator in a gas mask configuration).
 5. Mersorb-P100 cartridges can be used against a mixture of chlorine and mercury that are both present simultaneously, but cannot be used if alternating between mercury-contaminated atmospheres and chlorine-contaminated atmospheres.
- E. TIME USE LIMITATION
1. Canisters and cartridges with an N95 or R95 filter shall be limited to 8 hours of use (continuous or intermittent) against particulates. (Service time can be extended by performing an evaluation in the specific workplace setting that demonstrates (a) that the extended use will not degrade the filter efficiency below 95%, or that the total mass loading of the filter is less than 200mg for a single canister application or less than 100 mg each for a dual cartridge application).
 2. GMHF-C-P100 and Hydrogen Fluoride/P100: Canister must be replaced after each use against hydrogen fluoride (not to exceed 8 hours) to ensure the integrity of the P100 filter.
- F. MULTI-USE LIMITATIONS (**OptiFilter XL only**)
1. Approved as a high efficiency particulate air filter on approved Powered Air Purifying Respirators. Also, approved as a P100 filter, but ONLY when used with an approved negative pressure respirator. Do not exceed maximum use concentrations established by regulatory standards.

EXPOSURE LIMITS

A listing of applicable exposure limits from the following sources is provided in MSA's Response® Respirator Selector: available online at www.MSAnet.com.

- American Conference of Governmental Industrial Hygienists (ACGIH)
 - Occupational Safety and Health Administration (OSHA)
 - National Institute for Occupational Safety and Health (NIOSH)
 - American Industrial Hygiene Association (AIHA)
- Contact MSA at 1-800-MSA-2222 for information.

EXPOSURE LIMITS FOR MIXTURES

The American Conference of Governmental Industrial Hygienists (ACGIH) publishes the following information to determine the TLV of a mixture.

First, determine the total concentration of the chemical mixture (C_{Mixture}) from the individual contaminant concentrations (C_1, C_2, C_3, \dots) using the following formula:

The TLV of the mixture is found by using the following formula where T_1, T_2, T_3, \dots are the individual contaminant TLVs and C_1, C_2, C_3, \dots are the individual contaminant concentrations:

$$T_{\text{mixture}} = \frac{C_{\text{mixture}}}{\frac{C_1}{T_1} + \frac{C_2}{T_2} + \frac{C_3}{T_3}}$$

Only use these equations if the contaminants present are actually mixed. Some substances do not mix and may be present separately, for example, in pockets or at different levels. In that case, the lowest TLV of the substances present must be used to determine the appropriate respirator category for protection against all contaminants present.

See MSA's Response® Respirator Selector for additional information.

SIZE SELECTION

Regardless of facial dimensions and respirator sizing charts, an actual respirator fit test, either qualitative or quantitative must be performed to ensure selection of the correct respirator size.

Fit test the respirator size relative to your facial features and dimensions. The Safety Administrator or Program Manager might assist in selecting the initial size to try.

Carefully don the respirator and conduct a Negative Pressure Seal test. See donning instructions for procedure.

If the respirator does not pass the Negative Pressure Seal Test or feels uncomfortable, try the next size. If other than facial seal leakage is detected, the condition must be investigated and corrected before another test is made.

Passing the Negative Pressure Seal Test does not verify that the size is correct. Size selection must be verified by successfully passing either a qualitative or quantitative Respirator Fit Test. If the respirator passes a Negative Pressure Seal Test but DOES NOT pass a Respirator Fit Test, try the next size.

Once the correct size is selected, the respirator must pass a Negative Pressure Seal Test every time the mask is donned to ensure proper fit before using the respirator.

The respirator must also pass the tightness test before the user attempts to enter a toxic atmosphere.

The respirator will not furnish protection unless all inhaled air is drawn through a suitable canister/cartridge(s).

RESPIRATOR FIT TEST

⚠ WARNING

The user must perform a respirator fit test (Quantitative Test or Qualitative Test) and follow all warnings and limitations specified. Failure to do so can result in serious personal injury or death.

A qualitative or quantitative respirator fit test must be routinely carried out for each wearer of this respirator to determine or confirm the amount of protection that the respirator provides. The fit test method chosen may impact the maximum use concentration.

Respirator fit tests are explained fully in the American National Standard Practices for Respiratory Protection, ANSI Z88.2-1992 which is published by the American National Standards Institute, 11 West 42nd Street, New York, New York, 10036 and Occupational Safety and Health Standards, OSHA 1910.134, which is published by the Occupational Safety and Health Administration, 200 Constitution Avenue, NW, Washington DC, 20210.

PREPARING THE RESPIRATOR FOR USE

CHECKPOINTS BEFORE USE

1. Check that all parts of the respirator are complete and undamaged. See the Inspection section for Inspections Procedures.
2. Check that the filter canister/cartridge(s) approval is appropriate and effective against the contaminant in the environment.

⚠ WARNING

When using the Advantage 4000 twin cartridge inlet assembly, ensure that the inhalation valve disc is laying flat against the adapter orifice. Failure to follow this warning can result in serious personal injury or death.

INSTALLING/REPLACING THE CANISTER/CARTRIDGE(S)

⚠ WARNING

Verify the contaminant(s) in the environment before entering. Always check that the filter canister/cartridge(s) is appropriate for use in the environment. A filter canister/cartridge(s) which is not designed for the contaminant present may not provide protection.

Failure to follow this warning can result in serious personal injury or death.

After verifying that the canister/cartridge(s) type is appropriate for use in the environment

1. Verify shelf life expiration date on carton, bag, and canister/cartridge(s) label has not been exceeded.

⚠ WARNING

- **DO NOT** use an expired canister/cartridge.
- **DO NOT** use the canister/cartridge(s) if the bag is opened, damaged, or missing. Canisters/ cartridges must be in their original packaging prior to use in a contaminated environment. Do not reuse the canister/cartridge(s).

Failure to follow this warning can result in serious personal injury or death.

2. Remove canister/cartridge(s) from its packaging.
3. Inspect the canister/cartridge(s) to be sure that it is not damaged.
4. Thread the filter canister/cartridge(s) into the facepiece port and hand-tighten.

If applicable, place a new filter in each filter cover. Never load filters into the receptacles.

Use the canister/cartridge(s) immediately upon opening the bag.

Note: For gas mask canister, refer to the shelf life section for storing the canister outside the packaging. Discard canister/cartridge(s) after each use.

Replace the canister/cartridge(s) before each use. Follow the established canister/cartridge(s) change-out schedules to ensure that canister/cartridge(s) are replaced before breakthrough occurs. When used at defined occupational exposure limits, the rated service time cannot be exceeded.

Replacement of the Mersorb P100 cartridge must occur when the end-of-service-life indicator turns brown.

After using the respirator in a gas mask application for escape, the canister must be replaced before reusing the respirator.

⚠ WARNING

DO NOT replace canister/cartridge(s) in a contaminated area. Be sure to follow applicable decontamination procedures. Failure to follow this warning can cause inhalation of contaminated air, resulting in serious respiratory injury or death.

When the mask is adjusted properly, the wearer should not taste or smell the contaminant, or experience eye, nose, or throat irritation. The wearer's inhalation resistance should be as experienced during training.

⚠ WARNING

- **If the respirator does not perform as specified, it must not be used until it has been checked by authorized personnel.**
- **Return to a non-contaminated area immediately if you experience nausea, dizziness, eye irritation, unusual odor or taste, excessive fatigue, or difficulty breathing.**
- **When using canisters in an application that produces sparks, ensure that they are protected by a shield. Contact with sparks can damage filters and reduce protection.**

DONNING

⚠ WARNING

When Using the Advantage 4000, ensure the inhalation valve disc is laying flat against the adapter orifice. Failure to follow this warning can result in serious personal injury or death.

DONNING THE FACEPIECE WITH THE CLOTH HEAD HARNESS

1. Loosen the harness straps until the end tabs are at the buckle.
2. Grasp the harness straps.

3. Insert chin into the chin cup.



4. Pull the harness over the head so that the netting lies flat and is centered behind your head.



5. Hold the facepiece by the inlet housing while tightening the lower straps. Pull them straight back, not out.



6. Tighten the upper straps.



7. Adjust the straps as necessary until the facepiece fits snugly against the face.



8. Ensure that straps are adjusted to same lengths from left to right sides of the facepiece.



9. Perform a negative pressure seal test.



DONNING

DONNING THE FACEPIECE WITH RUBBER HARNESS

1. Loosen the harness straps until the end tabs are at the buckle. Grasp the harness straps.



2. Insert chin into the chin cup.

3. Pull the harness back over head.
4. Pull the back of harness downward toward the neck until it's centered at the back of your head.
5. If necessary, hold the center of the facepiece inlet assembly with one hand and position the harness with the other hand, until obtaining a firm and comfortable fit against the face at all points.

⚠ WARNING

DO NOT carry or support the Advantage 4000 APR by cartridges or filters. They are not intended to be load bearing components.

6. Tighten the neckstraps so that the mask fits snugly against the face.



Note: Make sure the back of the harness is centered on the back of the head.

7. The top two harness straps must be flat against the top of head.

Note: Both top straps should be adjusted with button in the same position so straps are equal in length.

8. If the mask does not feel snug, loosen the bottom straps and reposition the back of the harness. Make sure that the back of the harness is positioned on the back of the head. If the mask does not become snug against the face, remove the mask and adjust the length of the top two straps.

Adjusting the Top Straps

1. Remove the strap from the button by pulling the loose end of the strap away from the button.

2. Move the slide away from the lens ring to allow the strap to slide through the lens ring connection. Adjust the length of the strap. Secure the strap in position by pulling the strap onto the button.



3. Smooth the straps so that they are flat. Move the slide so that it is located at the lens ring connection.

NEGATIVE PRESSURE SEAL TEST

The Negative Pressure Seal Test must be performed each time the facepiece is donned. A good face-to-facepiece seal must be verified before entering a hazardous area.

Perform the test as follows:

1. Ensure respirator is assembled properly.
2. Block off canister/cartridge(s) inlet using the palm(s) of the hand(s).
3. Inhale gently and hold breath for 10 seconds. If the seal is good, the facepiece will collapse and remain collapsed against face. Remove hands and breathe normally.
4. If the facepiece did not remain collapsed during the test, or any leakage is noticed, readjust straps and perform Negative Pressure Seal Test again.
5. If this does not correct the leak, the mask will not provide protection. If the leakage is from the face seal, a different size mask may provide a good seal. If other than face seal leakage is detected, the condition must be corrected before performing another test.

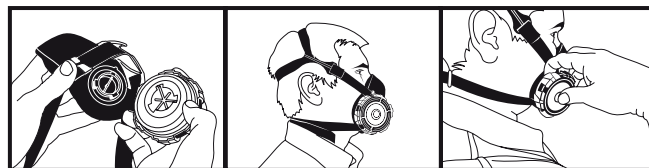

P100 with Splash Guard Method - Support the cartridge from behind using your fingers and depress the button with your thumb. Gently inhale so that the facepiece collapses slightly and hold breath for ten seconds. The facepiece will remain collapsed while the breath is held, unless there is a leak in the seal.

INSPECTION

NOTE: If a leak is detected, adjust the straps or reposition the facepiece, ensure the push button is completely depressed, and repeat test until no leakage is detected.

⚠ WARNING

This device may not seal properly with your face if you have a beard, gross sideburns, or similar physical characteristics (see ANSI Z88.2). An improper facial seal may allow contaminants to leak into the facepiece, reducing or eliminating respiratory protection. Do not use this device if such conditions exist. The negative pressure seal test must be conducted and passed before each use. Never remove the facepiece except in a safe, non-hazardous, non-toxic atmosphere. Failure to follow this warning can result in serious personal injury or death.

REMOVING THE RESPIRATOR WITH RUBBER HARNESS

To remove the facepiece:

1. Push the bottom buckles forward to loosen and fully extend the bottom straps.
2. Grasp the inlet assembly and pull the mask up and away from face.

REMOVING THE RESPIRATOR WITH CLOTH HARNESS

To remove the facepiece:

1. Push the bottom buckles forward to loosen and fully extend the bottom straps.



2. Push the upper buckles forward to loosen the upper straps.
3. Grasp the inlet assembly and pull the mask up and away from face.

MAINTENANCE

This respirator must be kept in good condition to function properly. When any respirator shows evidence of excessive wear or damage, it must be replaced immediately. This respirator, when not in use, should be stored in a clean dry location, such as its storage bag. Do not distort

the facepiece during storage. When disposing of the respirator or its components, do so in accordance with local, state and federal regulations.

REPAIR

Note: All repair procedures assume that the respirator is clean and free of contaminant and that the filter(s)/cartridge(s) are removed.

Removing the Inlet Assembly

1. Press the Inlet assembly release button.

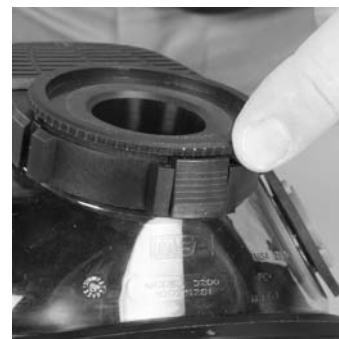

Plugged Inlet Assembly

2. Rotate the adapter clockwise a quarter turn until the notch and part number are at 9:00 o'clock.



RD40 Inlet Assembly

3. Firmly pull the inlet assembly from the facepiece assembly by grasping the inlet assembly and base of the facepiece.

Inlet Assembly Instructions

⚠ CAUTION

DO NOT use a sharp object to remove the o-ring. A damaged o-ring will not form an adequate seal with the facepiece.

Disassembling the Twin-Cartridge Inlet Assembly

1. Carefully roll the o-ring out of its groove and discard.
2. Carefully pry open the exhalation cover.
3. Depress Inlet assembly release button. Rotate the handwheel 135 degrees (3/8-turn) clockwise. Pull the adapter off the inlet assembly and rotate it another 45

INSPECTION

- degrees (1/8-turn).
- Carefully remove the button, allowing the springs to fall out.
 - Pull the adapter and the twin-cartridge manifold apart, taking care not to drop the O-ring between them.
 - Discard the O-ring.
 - Remove the gaskets from the bayonet fittings.
 - Gently pull the inhalation valve disc from the stem.
 - Inspect the valve for any damage and replace if necessary.
 - Fold the exhalation valve in half and gently pull out of the component housing.
 - Inspect the valve seat for any damage and replace if necessary.

Disassembling the Plugged Inlet Assembly

- Carefully roll the o-ring out of its groove and discard.
- Carefully pry open the exhalation cover.
- Depress the button on the inlet housing. Facing the front of the inlet assembly, rotate the adapter 135 degrees (3/8-turn) clockwise. Pull the adapter off the inlet assembly.
- Carefully remove the button, allowing the springs to fall out.
- Gently pull the inhalation valve disc from the stem.
- Inspect the valve disc and seat for damage and replace if necessary.

Disassembling the RD40 Inlet Assembly

- Carefully roll the o-ring out of its groove and discard.
- Carefully pry open the exhalation cover.
- Depress Inlet assembly release buttonFacing the front of the inlet assembly, rotate the adapter 135 degrees (3/8-turn) clockwise. Pull the adapter off the inlet assembly.
- Carefully remove the button, allowing the springs to fall out.
- Grasp the tab on the spider gasket and gently pull it out.
- Gently pull the inhalation valve disc from the stem.
- Inspect valve for any damage. Replace if necessary.
- Gently pull the exhalation valve disc from the stem.
- Inspect the valve disc and seat for damage and replace if necessary.

Disassembling the PTC Inlet Assembly

- Carefully roll the o-ring out of its groove and discard.
- Carefully pry open the exhalation cover.
- Depress the button on the inlet housing. Facing the front of the inlet assembly, rotate the adapter 45 degrees (3/8-turn) clockwise. Pull the adapter off the inlet assembly and place it on your working surface with the valve side up if applicable.
- Gently pull the inhalation valve disc from the stem.
- Inspect valve disc and stem for damage. Replace if necessary.
- Carefully release the button over your working surface, allowing the springs to fall out.
- Carefully remove the clip. Do not damage the spring

or valve.

- Place clip, spring, valve, and valve stem assembly (contained within rubber valve) on your working surface.
- Remove rubber valve from valve stem assembly. The inlet assembly is now completely disassembled. It may be cleaned using a non-sudsing cleaning solution such as Confidence Plus® Cleaning Solution (P/N 10009971)

⚠ CAUTION

Inspect all parts for damage before reassembly.

Reassembling the Twin-Cartridge Inlet Assembly

- Lightly lubricate exhalation valve stem with Christo-Lube (PN 604070) or similar fluorinated lubricant.
- Carefully press the valve stem into the orifice by pushing in the center of the valve face.
- Locate the button and place a small spring in each hole.
- Put the button into mating cavity and locate the adapter
- Place a new o-ring on twin-cartridge manifold seat and insert it into the serrated adapter with wider rib to the left and serrated adapter inverted.
- Rotate the notched adapter 180 degrees so that model number is visible and upright. Larger of the two ribs should be to the left.
- Pull the components apart gently to ensure that they are fully engaged.
- Rotate serrated adapter 3/8-turn clock-wise.
- Insert adapter into grooved channels by locating recessed button cavity.
- Press adapter into place and rotate adapter 3/8-turn counter-clockwise until it locks.
- Roll a new o-ring into position on the groove/interface between the serrated adapter and the component housing.
- Place the hinge tabs into the slots.
- Snap the cover into place.
- Carefully stretch the valve disc over the stem in the center of the adapter.
- Replace the bayonet gaskets on the fittings of the manifold.

The Twin-Cartridge Inlet Assembly is now ready for use with the Advantage 4000 facepiece.

Reassembling the Plugged Inlet Assembly

- Lightly lubricate exhalation valve stem with Christo-Lube (PN 604070) or similar fluorinated lubricant.
- Carefully press the valve stem into orifice by pushing in the center of the valve face
- Locate the button and place a small spring in each hole.
- Put the button into mating cavity and locate the adapter.
- Insert the adapter into the grooved channels by locat-

INSPECTION

- ing recessed button cavity.
6. Press the adapter into place and rotate the adapter 3/8-turn counter-clockwise until it locks.
 7. Roll a new o-ring into position on the groove between the plugged adapter and the component housing. Locate the exhalation cover.
 8. Place the lower tabs of the cover into the inlet assembly.
 9. Snap the top half of the cover into place.

The plugged Inlet Assembly is now ready for use with the Advantage 4000 Facepiece.

Reassembling the RD40 Inlet Assembly

1. Lightly lubricate exhalation valve stem with Christo-Lube® (PN 604070) or similar fluorinated lubricant.
2. Carefully press the valve stem into orifice by pushing in the center of the valve face
3. Locate the button and place a small spring in each hole.
4. Put the button into mating cavity and locate the adapter.
5. Insert adapter into grooved channels by locating recessed button cavity.
6. Press adapter into place and rotate adapter 3/8-turn counter-clockwise. A click will be heard when the button engages
7. Roll a new o-ring into position on the groove/interface between the RD40 adapter and the component housing. Locate the exhalation cover.
8. Place the hinge tabs into the slots. Snap the cover into place and locate the inhalation valve disc.
9. Carefully stretch the valve disc over the stem in the center of the spider gasket.
10. Replace the spider gasket valve in the seating groove inside of the RD40 Adapter.

The RD40 Inlet Assembly is now ready for use with the Advantage 4000 facepiece.

Reassembling the PTC Inlet Assembly

1. Lightly lubricate exhalation valve orifice.
2. Carefully insert disc portion of valve stem into orifice and stretch around until stem and valve are fully engaged and properly oriented.
3. Insert valve stem shaft into exhalation port of component housing.
4. Place exhalation pressure demand spring on spring retaining clip and, while holding spring on clip, set opposite end of spring in valve crown portion of exhalation valve.
5. Firmly press spring retaining clip sides into matching holes on component housing until engaged
6. Locate the button and place a small spring in each hole.
7. Put the button into mating cavity and locate adapter
8. Insert adapter into grooved channels by locating recessed button cavity.
9. Press adapter into place and rotate adapter 3/8-turn

- counter-clockwise until it locks into place.
10. Roll a new O-ring into position on the groove/interface between the PTC adapter and the component housing. Locate the exhalation cover.
11. Place the lower tabs of the cover into the mating grooves above the adapter.
12. Snap the cover into place and locate the inhalation valve disc
13. Carefully stretch the valve disc over the post in the center of the adapter

The PTC Inlet Assembly is now ready for use with the Advantage 4000 facepiece.

Disassembling the Facepiece: Model 4100 and 4200

1. Remove the U-clip from the inlet housing front by spreading away from the inlet assembly and sliding it down. Set the U-clip aside.
2. Push the inlet housing through the facepiece lens by applying inward force at bottom of inlet housing
3. Remove the nosecup by grasping to close to the inlet housing flange.
4. Remove and discard the small internal o-ring.
5. Remove the larger external o-ring and replace.
6. Set the inlet housing aside.
7. Holding the nosecup, gently push the inlet check valves from inside and through the nose-cup.
8. Inspect the silicone valves for any damage. Replace if damaged.

Disassembling the Facepiece: Model 4200 only

1. To replace the inhalation valves on the lens bayonet connectors, line the holes up in the valves with the posts on the back of the lens bayonet connectors and gently stretch the valve openings to slip over the posts
2. Remove the bayonet connector gaskets by stretching the gaskets slightly and lifting them over the bayonet connectors.

Removing the Lens from the Facepiece Blank

1. Remove the head harness. See the Removing the Head Harness section.
2. Using a Phillips screwdriver, unthread and remove the two screws securing the lens rings.
3. Separate the lens rings by inserting a flat head screwdriver into the rear notch of each side until it is seated firmly.
4. Carefully rock the screwdriver up and down until either half can be pulled from the facepiece blank by hand.
5. Fold back the facepiece blank and remove the lens. Set all components aside. Do not discard.

CAUTION

DO NOT allow the screwdriver blade to contact any portion of the facepiece blank.

Reassembling the Facepiece

1. To reassemble facepiece, reverse the preceding direc-

INSPECTION

tions with the exception of the lens which is reassembled as per the following instructions.

Before use, perform negative pressure test to insure proper reassembly of Advantage 4000 Respirator. If any portion of facepiece does not seal, remove from service and inspect/service immediately.

⚠ CAUTION

Before installing a new lens, check the blank groove for dirt or other debris, which may interfere with a seal between the lens and blank.

Reassembling the Lens

1. Insert the top of the lens into the top of the facepiece blank.



2. Mold the blank around the lens, checking to be sure that the lens is centered in the facepiece blank.

3. Stretch the blank enough to insert the bottom of the lens into the blank.
4. Guide the lens into the blank groove all the way around the lens. Ensure the lens is fully captured in the blank groove.
5. Guide the top lens ring over the outside of the facepiece blank lens groove, ensuring that the harness straps are at the back of the facepiece.
6. Guide the bottom lens ring over the outside of the bottom facepiece blank lens groove.



7. Work the lens rings down on to the facepiece blank to line-up the threaded ends as close as possible without bending the lens.

8. Install one Phillips screw in the top lens ring-mounting flange and thread it about halfway into the opposite lens ring flange.



9. Install the remaining Phillips screw in the other lens ring-mounting flange and thread it about half way into the opposite lens ring flange.
10. Alternate tightening the screws until the lens is secure.
11. Reinstall the Component Housing parts as described above.
12. Don the facepiece and perform the Negative Pressure Seal Test

RUBBER HARNESS STRAPS DISASSEMBLY

Top Straps

Unbutton the top straps and slide the straps back through retainer. Pull the top straps through slot in lens rings.



Bottom Straps

Unthread both bottom straps through the buckles.

Buckles

The bottom buckles are detachable. Grasp the buckle and the facepiece tab and push them together until the button is free.



INSPECTION

RUBBER HARNESS STRAPS REASSEMBLY

1. Place the new harness on a flat surface with the MSA logo facing "right-side up." In this position, the straps above the logo are the top straps.
2. Grasp one top strap and fold the end-tab in half.
3. From the "face" side of the facepiece, insert the end tab under the slot in lens ring.
4. Thread the end-tabs up through the lens ring slots and pull strap through several inches.

Attach the bottom straps to the bottom, detachable buckles:

1. Place the buckle's button-hole over the button.
2. Grasp a facepiece tab and buckle in each hand and pull them apart until the button snaps into the button-hole.
3. Ensure the strap is not twisted and that the boss on end-tabs side is facing up (away from the inside of the facepiece).
4. Thread the end tabs with the boss facing up, through the bottom slot of buckles, then over center bar, down through top slot of buckles.
5. Pull straps through buckles.
6. Don the facepiece and perform the Negative Pressure Seal Test.

CLOTH HEAD HARNESS DISASSEMBLY

Removing the Cloth Head Harness

1. Removing the upper strap.
 - At the top of the lens ring, fold the mask rubber down against the lens.
 - Push the straps and netting down against the lens, pivoting the upper buckle on the adapter clip
 - Pull upper buckle down, pulling them out of the adapter clip.

Replacing the Cloth Head Harness

1. Removing the bottom strap
 - Grasp the metal buckle and the facepiece tab. Push them together until the button is free from the buckle.

Removing the Adapter Clip

1. Slide the blade of a flathead screwdriver between the top of the lens ring and each black clip.
2. Pivot the screwdriver until the clip disengages.

Replacing the Cloth Head Harness

Note: Adapter clips are identified with an "R" or "L" indicating right and left sides.

1. Reassemble the adapter clips by pressing them into lens rings until fully engaged..

2. Installing the top straps.
 - Place the new harness on a flat surface so the straps behind the MSA logo are the top straps.
 - Ensure the black adapter clips are engaged.
 - Fold the mask rubber down against the lens.
 - Slide the slotted part of the black upper buckle up into its respective side's black adapter clip.
 - Pivot the upper buckle up and pull the strap, ensuring proper assembly.
3. Install the bottom strap
 - Place the metal buckles bottom-hole over the button then grasp a mask tab and buckle in each hand and pull them apart until the button shaft snaps into the button hole.
 - Thread the strap ends through the forward slot of the buckles, then over center bar, down through the rear slot of the buckles. Pull strap through the buckles.
 - Ensure no straps have become twisted. All straps should lay flat against the head when the facepiece is donned.
 - Perform a Negative Pressure Seal Test to insure that a seal has been achieved.

Note: All procedures are from the "face" side of mask.

1. Fold the mask rubber against lens.
2. Slide the slotted part of top strap under the Adapter Clip, push the slotted part into Adapter Clip. Pull on strap to ensure it is secure in Adapter Clip.
3. Make sure the strap is not twisted and ensure the strap moves freely.

Bottom Straps

Attach the bottom straps to the bottom, detachable buckles:

1. Place the buckle's button-hole over the button then grasp a mask tab and buckle in each hand and pull them apart until the button snaps into the button hole.
2. Make sure the strap is not twisted, and that the boss on end-tabs side is facing up (away from the inside of the mask).
3. Don the mask and perform the Negative Pressure Seal Test.

Adapter Clips Reassembly

Note: All procedures are from "face" side of mask.

1. The adapter clips are identified with an "R" or "L". "R" is for right side. "L" is for self side of lens ring.
2. With the "R" or "L" must face into the center of the mask and to the back of lens ring.
3. Push the new adapter clip over the boss of the lens ring.
4. Ensure the adapter clips are tight on lens ring.

REMOVING THE RESPIRATOR

DECONTAMINATION

⚠ WARNING

DO NOT remove respirator until respirator and protective clothing are decontaminated; otherwise, exposure to contaminants may result. Follow decontamination and disposal procedures established by appropriate authorities. Failure to follow this warning may result in serious personal injury or death.

Once the protective equipment has been decontaminated, proper disposal of affected equipment must be performed. Disposal is to be performed as required by federal, state, and/or local laws.

PROCEDURE FOR REMOVING THE RESPIRATOR

1. To remove the facepiece, insert the thumbs under each of the harness head straps end tab and fully extend the harness head straps.
2. Grasp the facepiece by the component housing or bottom head harness straps (not the exhalation valve or canister/cartridge(s)).
3. Pull it up and away from the face.

Note: Before the next use, check the respirator facepiece and if necessary, clean and disinfect. Always use a new canister/cartridge(s). Do not reuse the canister/cartridge(s).

CLEANING AND DISINFECTING

⚠ CAUTION

DO NOT use alcohol as a germicide because it may deteriorate rubber parts.

Depending on the cleaning policy adopted, either a designated person or the user should clean the respirator after each use. Non-sudsing Confidence Plus® Cleaning Solution (P/N 10009971) from MSA is recommended. It is a germicidal cleaner that cleans and disinfects in one operation. It retains its germicidal efficiency in hard water to inhibit the growth of bacteria. It will not deteriorate rubber, plastic, glass, or metal parts. Refer to the label for use instructions. A solution as effective as Confidence Plus Cleaning Solution and compatible with MSA respirator components may be substituted. ANSI suggests that users be trained in the cleaning procedure.

⚠ WARNING

Be careful not to inhale or touch the contaminant in handling the respirator or its parts. If necessary, use equipment disposal to protect you from the specific contaminant. Failure to follow this warning can result in serious personal injury or death.

1. Preparing Solution
 - a. Follow the instructions with the Confidence Plus Cleaning Solution.
 - b. If the Confidence Plus Cleaning Solution is not used, wash in a mild cleaning solution, rinse thoroughly, and submerge in a germicide solution for the manufacturer's recommended time.
2. Clean and Disinfect the Facepiece
 - a. Remove the canister/cartridge(s) from the facepiece.

- b. Thoroughly wash the facepiece (and nose cup) in the cleaning solution. A soft brush or sponge can be used to clean the soiled facepiece. Be sure to include cleaning the exhalation valve and seat.
- c. Rinse the facepiece and components in clean, warm (110°F), water (preferably running and drained).

⚠ CAUTION

If not rinsed thoroughly, cleaning agent residue may irritate the wearer's skin.

- d. Allow the facepiece to air dry, face up. Do not dry the parts by placing them near a heater or in direct sunlight. The rubber will deteriorate.
- e. Operate the exhalation valve by hand to be sure it works properly.
- f. Harness (straps and buckles)
- g. The facepiece and components should be air-dried or hand-dried with a clean lint-free cloth.

⚠ CAUTION

DO NOT force-dry the parts by placing them in a heater or in direct sunlight. The rubber will deteriorate. When facepiece is thoroughly dried, store the facepiece in the clam shell in which it was shipped.

STORAGE

Store only undamaged respirators for further use. When not in use, store the respirator in cool, dry, and clean ambient air.

Do not distort the facepiece during storage. When disposing of the respirator or its components, do so in accordance with local, state, and federal regulations. Discard the canister/cartridge(s) if the original bag or carton is opened or damaged. For gas mask application only, see Storage and Shelf Life information below.

SHELF LIFE

Follow the shelf life expiration date stamped on the carton, bag, and/or canister/cartridge(s) as applicable. The expiration date will only apply if factory sealed and undamaged or the proper procedure is followed, otherwise the canister must be discarded.

⚠ WARNING

DO NOT use an expired canister/cartridge(s). Failure to follow this warning can result in serious personal injury or death.

Storage and Shelf Life for Canister Part Numbers 10059903, 10067469, and 10067470 Stored Outside the Original Foil Packaging:

These canisters have a 5 year shelf life with the expiration date printed on the foil bag. The canisters may be stored outside the original factory packaging by using the following procedure:

Approved Storage Configurations Outside the Original Foil Packaging

Storage using the supplied cap/plug component

1. Remove the canister from the box and bag.
2. Locate the white block on the canister label.
3. Mark on the canister, in the white block, an expiration date of 1 year (for formaldehyde canister an expiration date of 6 months) from the date the canister was removed from the packaging. This expiration date must not to exceed the original expiration date printed on the foil packaging.

4. Using the enclosed cap and plug assembly as shown in Figure A, place the cap end over the threaded outlet of the canister as shown in Figure B.
5. Insert the plug end on the inlet of the canister as shown in Figure C.
6. Using thumbs, press in the center of both the cap and the plug ends to ensure the cap/plug is firmly in place and the canister is sealed.
7. Discard cap/plug after each use.

Storage in user supplied case

1. Remove the canister from the box and bag.
2. Locate the white block on the canister label.
3. Mark on the canister, in the white block, an expiration date of 1 year (for formaldehyde canister an expiration date of 6 months) from the date the canister was removed from the packaging. This expiration date must not to exceed the original expiration date printed on the foil packaging.
4. The canister must be attached to the facepiece with the plug side of the cap and plug component secured into position.
5. The respirator must be placed upright in the plastic case.
 - 10075204 Phosphine/Ammonia/Chlorine/P100
 - 10075205 Hydrogen Fluoride/P100
 - 10075206 Formaldehyde/Acid Gas/Chlorine Dioxide/Escape from Hydrogen Sulfide/P100
 - 10075207 Organic Vapor/P100
6. Ensure the lid is snapped tight and the case is closed.

⚠ WARNING

DO NOT store the canister above 120°F. Failure to follow this warning can alter the performance of the canister and result in serious personal injury or death.

ACCESSORIES

The facepiece may be equipped with the following accessories:

1. Cover Lens (clear or tinted), in small, medium, or large
2. Spectacle Kit

⚠ CAUTION

Refer to the NIOSH Approval Matrix for a complete list of Approved Accessories. If you must wear corrective eyewear, install an approved spectacle kit, listed on the NIOSH approval matrix insert.

⚠ WARNING

Know the contaminant(s) in the environment before entering. Always check that the filter canister/cartridge(s) is appropriate for use in the environment. A filter canister/cartridge(s) which is not designed for the contaminant present may not provide protection. Failure to follow this warning can result in serious personal injury or death.

Installing the Nosecup for Advantage 4000 Facepiece

1. Place nosecup into facepiece with notch of nosecup facing the bottom of facepiece.
2. Place bottom of nosecup under facepiece seal.
3. Stretch nosecup over Inhalation Valve Housing ensuring notch of nosecup is over tab of inhalation valve housing.
4. Stretch nosecup around lip on inhalation valve housing ensuring nosecup is in place.

Spectacle Kit

Spectacle kits are available for the Advantage 4000 (P/N 10029298). The kit includes the support assembly, a rubber block, and the spectacle frame. Prescription lenses can be obtained locally or through MSA.

Adjusting the Spectacles

1. To move the spectacles closer to your face, pull the frame prongs out of the rubber block.
2. To move the spectacles farther from your face, push the frame prongs into the rubber block.

3. To move the spectacles up or down, slide the rubber block up or down on the support arms.



Filter

1. Set the pre-filter pad into the filter cover.
2. Set the spacer on top of the pre-filter pad.
3. Fit the pre-filter cover assembly over the OptiFilter HE cartridge. Press firmly into place.

Attaching the Gas Mask Chin Canister to the Belt

This conversion kit consists of:

Qty.	Item	Part Number
1	Belt Clip	10068195
1	Breathing Tube	10068129
1	Belt	493702, 9961, 492827
1	Spark Cover	10068152

Installation Instructions

1. Attach the male thread end of the breathing tube securely to the facepiece component housing.
2. Slide the belt clip over the neck of the canister.
3. Securely fasten the female end of the breathing tube to the male end of the canister.
4. Attach the belt around the waist and attaché the belt clip to the belt.

Spark Cover (For Belt-Mounted Chin Style Gas Mask Canisters only)

1. Remove canister and spark cover from the packaging.
2. Attach the canister to the facepiece or breathing tube depending on the configuration being used.
3. Once the canister is attached, align the feet of the spark cover with the inlet hole of the canister.
4. Grasp the outside of the canister, twist and push on the spark cover. The spark cover will snap in place.
5. To remove the spark cover, gently squeeze the outside of the cover, twist, and pull the spark cover off.
6. Check the spark cover before each use to ensure no sparks have created holes or warped the part. If holes are created or the part is warped, replace the spark cover with a new one.

OTHER RESPIRATORY CONFIGURATIONS

This respirator can be used in other configurations that stated in these User's Instructions. Below is a list of these other configurations and the part number for the User's Instructions. Review the NIOSH matrix to verify the configuration that is being used is an approved configuration.

Approved Respirator	User's Instructions P/N
OptimAir MM2K	10020949

ADVANTAGE[®] 4000

ADVANTAGE 4000 ASSEMBLY	
PART NUMBER	DESCRIPTION
10075908	FACEPIECE ASSEMBLY, PD, SILICONE, MEDIUM
10075909	FACEPIECE ASSEMBLY, PD, HYCAR, MEDIUM
10075914	FACEPIECE ASSEMBLY, PD, SILICONE, SMALL
10075915	FACEPIECE ASSEMBLY, PD, HYCAR, SMALL
10075920	FACEPIECE ASSEMBLY, PD, SILICONE, LARGE
10075921	FACEPIECE ASSEMBLY, PD, HYCAR, LARGE

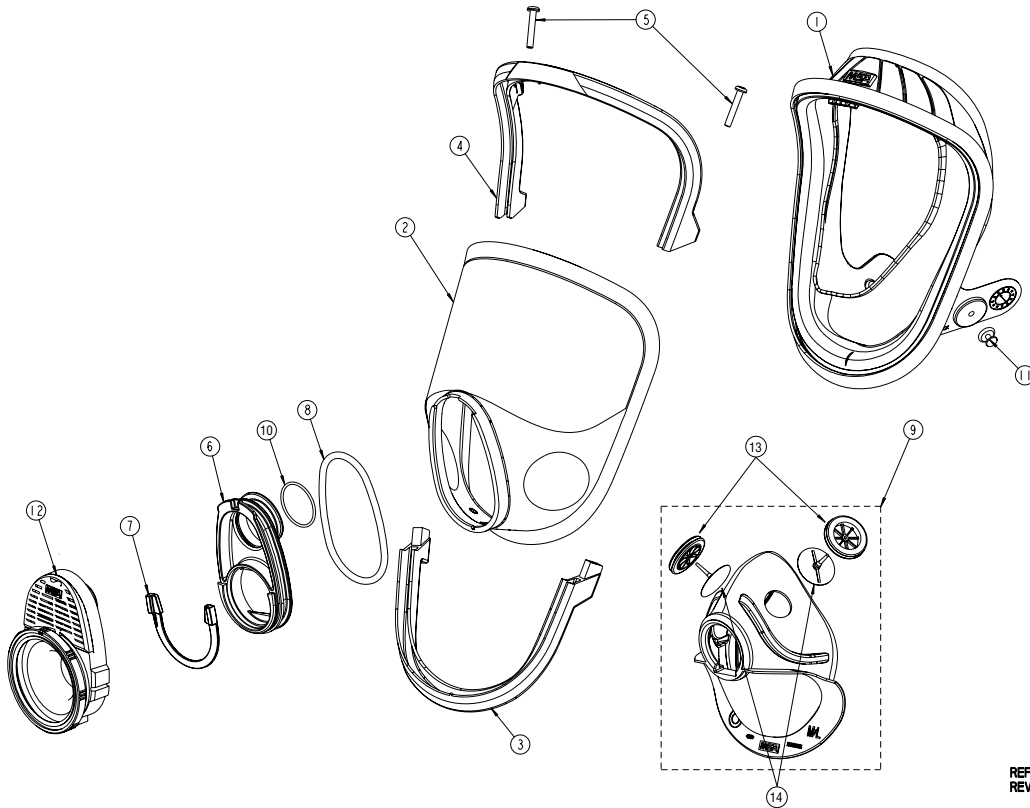

REFERENCE: 7-210-LINEART
REV.0

ADVANTAGE 4000 SINGLE PORT FACEPIECE COMPONENTS				ADVANTAGE 4000 SINGLE PORT FACEPIECE COMPONENTS (CONT.)			
ITEM NO.	PART NUMBER	QTY REQD	DESCRIPTION	ITEM NO.	PART NUMBER	QTY REQD	DESCRIPTION
1	10073455	1	FACEBLANK, HYCAR, SMALL	13	804822	2	INLET CHECK VALVE SEAT
	10073457		FACEBLANK, HYCAR, LARGE	14	804823	2	INLET CHECK VALVE DISC
	10073459		FACEBLANK, HYCAR, MEDIUM	NOT SHOWN	465008	1	BAG, DRAWSTRING
	10083926		FACEBLANK, SILICONE, SMALL		10029294	1	COVER, LENS
	10083927		FACEBLANK, SILICONE, LARGE		10075903	1	CLOTH HEAD HARNESS ASSEMBLY
	10083925		FACEBLANK, SILICONE, MEDIUM		NOSECUP ASSEMBLY COMPONENTS (NOT SHOWN)		
2	10074738	1	LENS, SINGLE PORT 4100-H	ITEM NO.	PART NUMBER	QTY REQD	DESCRIPTION
	10084808		LENS, SINGLE PORT 4100-S	KIT	10030794		CLASSIC RUBBER HARNESS KIT
KIT	10100417	1	LENS RING KIT	NOT SHOWN	10025286	1	RUBBER HARNESS
3	*		1-LENS, RING, LOWER, BLACK		10029406	2	SLIDE
4	*		1-LENS, RING, UPPER, BLACK		10025288	4	HARNESS BUTTON
5	*		2-SCREW, SST, 4MX25MM LG, PHIL PAN HD		10025287	2	BUCKLE
6	10061973	1	HOUSING, INLET		10030797		SLIDE (10029406) FOR CLASSIC RUBBER HARNESS, 10 PER PACKAGE
7	10061996	1	UCLIP		10030795		HARNESS BUTTON (10025288), 12 PER PACKAGE
8	10025297	1	O-RING, HOUSING, SILICONE		10030796		BUCKLE (10025287) FOR CLASSIC RUBBER HARNESS, 6 PER PACKAGE
9	10065803	1	NOSECUP ASSEMBLY, MED/LG				
	10065804		NOSECUP ASSEMBLY, SMALL				
10	10084819	1	O-RING, SIZE, 2-024				
11	10025288	2	BUTTON, HEAD HARNESS				
12	10065329	2	INLET ASSEMBLY				

ADVANTAGE[®] 4000

ADVANTAGE 4000 ASSEMBLY	
PART NUMBER	DESCRIPTION
10083792	FACEPIECE ASSEMBLY, SINGLE, SILICONE, MEDIUM
10083793	FACEPIECE ASSEMBLY, SINGLE, HYCAR, MEDIUM
10083796	FACEPIECE ASSEMBLY, SINGLE, SILICONE, SMALL
10083797	FACEPIECE ASSEMBLY, SINGLE, HYCAR, SMALL
10083900	FACEPIECE ASSEMBLY, SINGLE, SILICONE, LARGE
10083801	FACEPIECE ASSEMBLY, SINGLE, HYCAR, LARGE

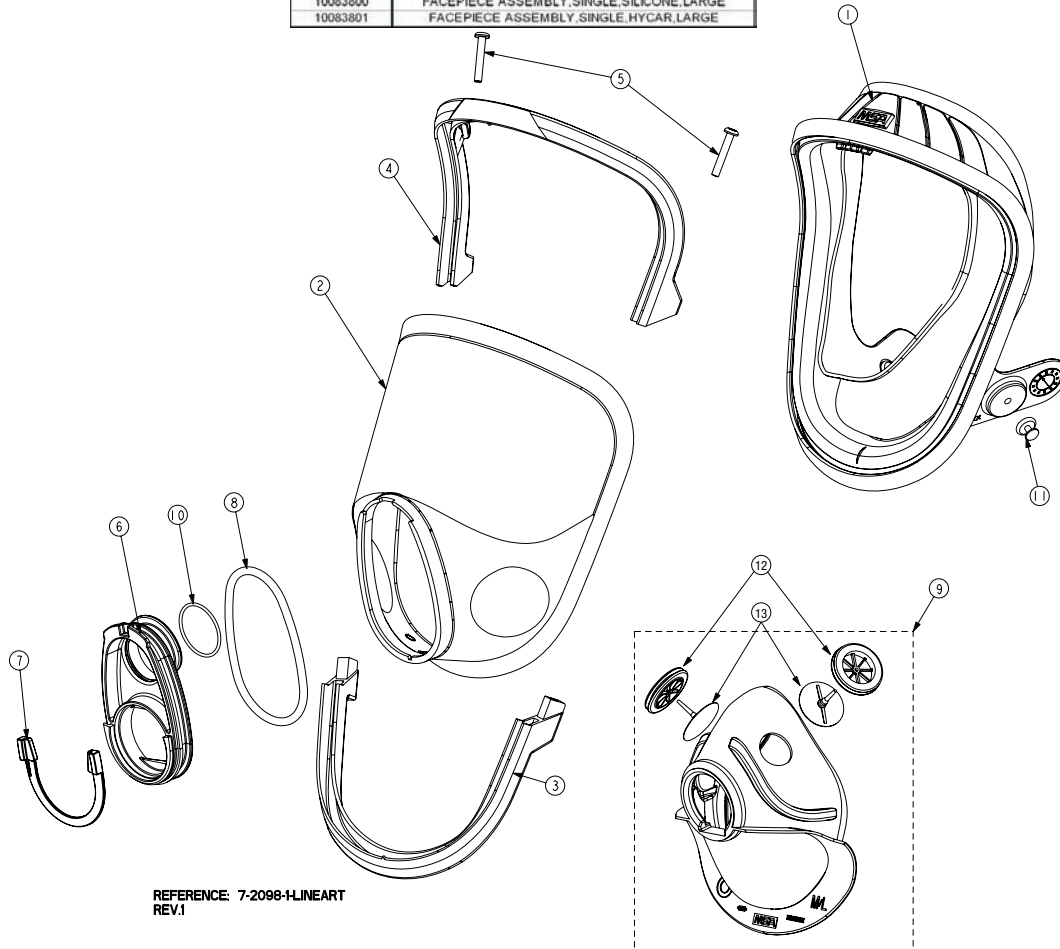

REFERENCE: 7-2098-HLINEART
REV.1

ADVANTAGE 4000 SINGLE PORT FACEPIECE COMPONENTS				ADVANTAGE 4000 SINGLE PORT FACEPIECE COMPONENTS (CONT.)			
ITEM NO.	PART NUMBER	QTY REQD	DESCRIPTION	ITEM NO.	PART NUMBER	QTY REQD	DESCRIPTION
1	10073455	1	FACEBLANK, HYCAR, SMALL	13	804823	2	INLET CHECK VALVE DISC
	10073457		FACEBLANK, HYCAR, LARGE	NOT SHOWN	465008	1	BAG, DRAWSTRING
	10073459		FACEBLANK, HYCAR, MEDIUM	10029294	1	COVER, LENS	
	10083926		FACEBLANK, SILICONE, SMALL	10075903	1	CLOTH HEAD HARNESS ASSEMBLY	
	10083927		FACEBLANK, SILICONE, LARGE	NOSECUP ASSEMBLY COMPONENTS (NOT SHOWN)			
	10083925		FACEBLANK, SILICONE, MEDIUM				
2	10074738	1	LENS, SINGLE PORT 4100-H	ITEM NO.	PART NUMBER	QTY REQD	DESCRIPTION
	10084808		LENS, SINGLE PORT 4100-S	KIT	10030794		CLASSIC RUBBER HARNESS KIT
KIT	10100417	1	LENS RING KIT	NOT SHOWN	10025286	1	RUBBER HARNESS
3	*	1-LENS, RING, LOWER, BLACK	10029406		2	SLIDE	
4	*	1-LENS, RING, UPPER, BLACK	10025288		4	HARNESS BUTTON	
5	*	2-SCREW, SST, 4MX25MM LG, PHIL PAN HD	10025287		2	BUCKLE	
6	10061973	1	HOUSING, INLET		10030797		SLIDE (10029406) FOR CLASSIC RUBBER HARNESS, 10 PER PACKAGE
7	10061996	1	UCLIP		10030795		HARNESS BUTTON (10025288), 12 PER PACKAGE
8	10025297	1	O-RING, HOUSING, SILICONE		10030796		BUCKLE (10025287) FOR CLASSIC RUBBER HARNESS, 6 PER PACKAGE
9	10065803	1	NOSECUP ASSEMBLY, MED/LG				
	10065804		NOSECUP ASSEMBLY, SMALL				
10	10084819	1	O-RING, SIZE, 2-024				
11	10025288	2	BUTTON, HEAD HARNESS				
12	804822	2	INLET CHECK VALVE SEAT				

ADVANTAGE[®] 4000

ADVANTAGE 4000 ASSEMBLY	
PART NUMBER	DESCRIPTION
10083760	FACEPIECE ASSEMBLY, TWIN, SILICONE, MEDIUM
10083781	FACEPIECE ASSEMBLY, TWIN, HYCAR, MEDIUM
10083784	FACEPIECE ASSEMBLY, TWIN, SILICONE, SMALL
10083785	FACEPIECE ASSEMBLY, TWIN, HYCAR, SMALL
10083788	FACEPIECE ASSEMBLY, TWIN, SILICONE, LARGE
10083789	FACEPIECE ASSEMBLY, TWIN, HYCAR, LARGE

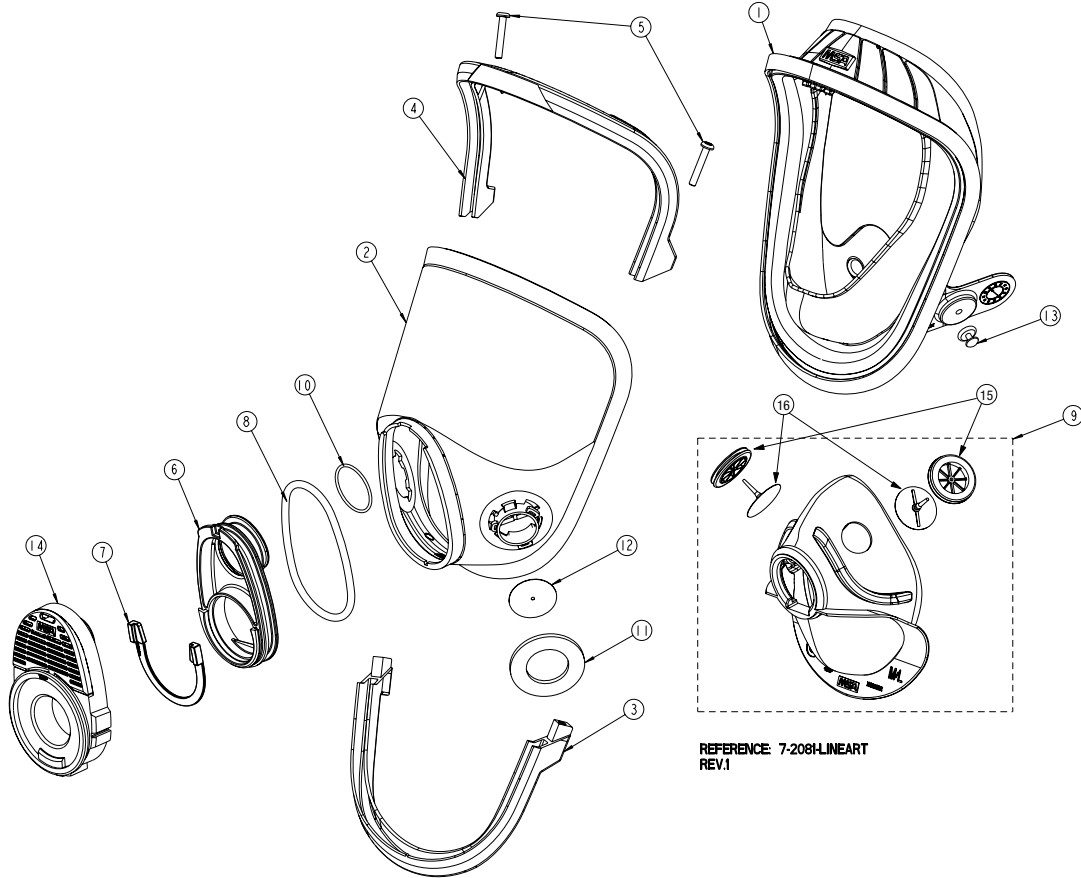

REFERENCE: 7-208H LINEART
REV.1

ADVANTAGE 4000 TWIN PORT FACEPIECE COMPONENTS				ADVANTAGE 4000 TWIN PORT FACEPIECE COMPONENTS (CONT.)			
ITEM NO.	PART NUMBER	QTY REQD	DESCRIPTION	ITEM NO.	PART NUMBER	QTY REQD	DESCRIPTION
1	10073455	1	FACEBLANK, HYCAR, SMALL	14	10065332	1	INLET ASSEMBLY
	10073457		FACEBLANK, HYCAR, LARGE	15	804822	2	INLET CHECK VALVE SEAT
	10073459		FACEBLANK, HYCAR, MEDIUM	16	804823	2	INLET CHECK VALVE DISC
	10083926		FACEBLANK, SILICONE, SMALL	NOT SHOWN	465008	1	BAG, DRAWSTRING
	10083927		FACEBLANK, SILICONE, LARGE	NOT SHOWN	10029294	1	COVER, LENS
	10083925		FACEBLANK, SILICONE, MEDIUM	NOT SHOWN	10075903	1	CLOTH HEAD HARNESS ASSEMBLY
2	10115696	1	LENS, TWIN PORT 4200-H W/BAYONET CONNECTORS	NOSECUP ASSEMBLY COMPONENTS (NOT SHOWN)			
	10115697		LENS, TWIN PORT 4200-S W/BAYONET CONNECTORS	ITEM NO.	PART NUMBER	QTY REQD	DESCRIPTION
KIT	10100417	1	LENS RING KIT	KIT	10030794		CLASSIC RUBBER HARNESS KIT
3	*		1-LENS, RING, LOWER, BLACK	NOT SHOWN	10025286	1	RUBBER HARNESS
4	*		1-LENS, RING, UPPER, BLACK		10107784	1	KEVLAR HEAD HARNESS
5	*		2-SCREW, SST, 4MX25MM LG, PHIL PAN HD		10029406	2	SLIDE
6	10061973	1	HOUSING, INLET		10025288	4	HARNESS BUTTON
7	10061996	1	UCLIP		10025287	2	BUCKLE
8	10025297	1	O-RING, HOUSING, SILICONE		10030797		SLIDE (10029406) FOR CLASSIC RUBBER HARNESS, 10 PER PACKAGE
9	10065803	1	NOSECUP ASSEMBLY, MED/LG	NOT SHOWN	10030795		HARNESS BUTTON (10025288), 12 PER PACKAGE
	10065804		NOSECUP ASSEMBLY, SMALL		10030796		BUCKLE (10025287) FOR CLASSIC RUBBER HARNESS, 6 PER PACKAGE
10	10084819	1	O-RING, SIZE, 2-024				
11	10018496	2	GASKET, BAYONET				
12	10030061	2	VALVE, FACEPIECE				
13	10025288	2	BUTTON, HEAD HARNESS				

ADVANTAGE[®] 4000

ADVANTAGE 4000 ASSEMBLY	
PART NUMBER	DESCRIPTION
10065332	ADVANTAGE 4000 INLET ASSEMBLY, PLUGGED

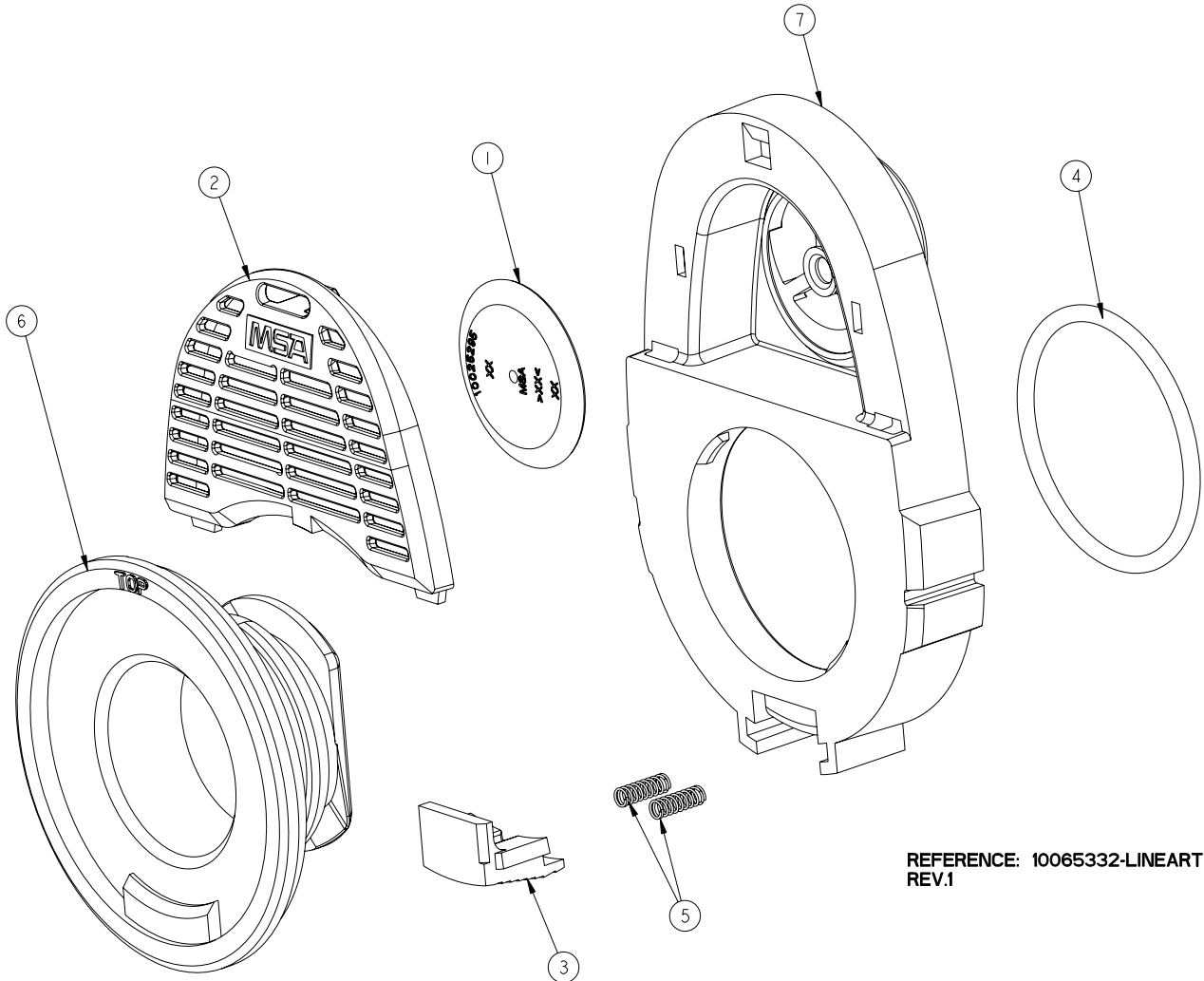

REFERENCE: 10065332-LINEART
REV.1

ADVANTAGE 4000 INLET ASSEMBLY, PLUGGED COMPONENTS			
ITEM NO.	PART NUMBER	QTY REQD	DESCRIPTION
1	10025295	1	VALVE, EXHALATION
2	10061974	1	COVER, EXHALATION
3	10061976	1	BUTTON, LOCKING
4	10065301	1	ORING, #128
5	10065303	2	SPRING
6	10065337	1	ADAPTER
7	10061975	1	HOUSING, COMPONENT
NOT SHOWN	604070	-	LUBRICANT

ADVANTAGE[®] 4000

ADVANTAGE 4000 ASSEMBLY	
PART NUMBER	DESCRIPTION
10065329	ADVANTAGE 4000 INLET ASSEMBLY, PUSH-TO-CONNECT

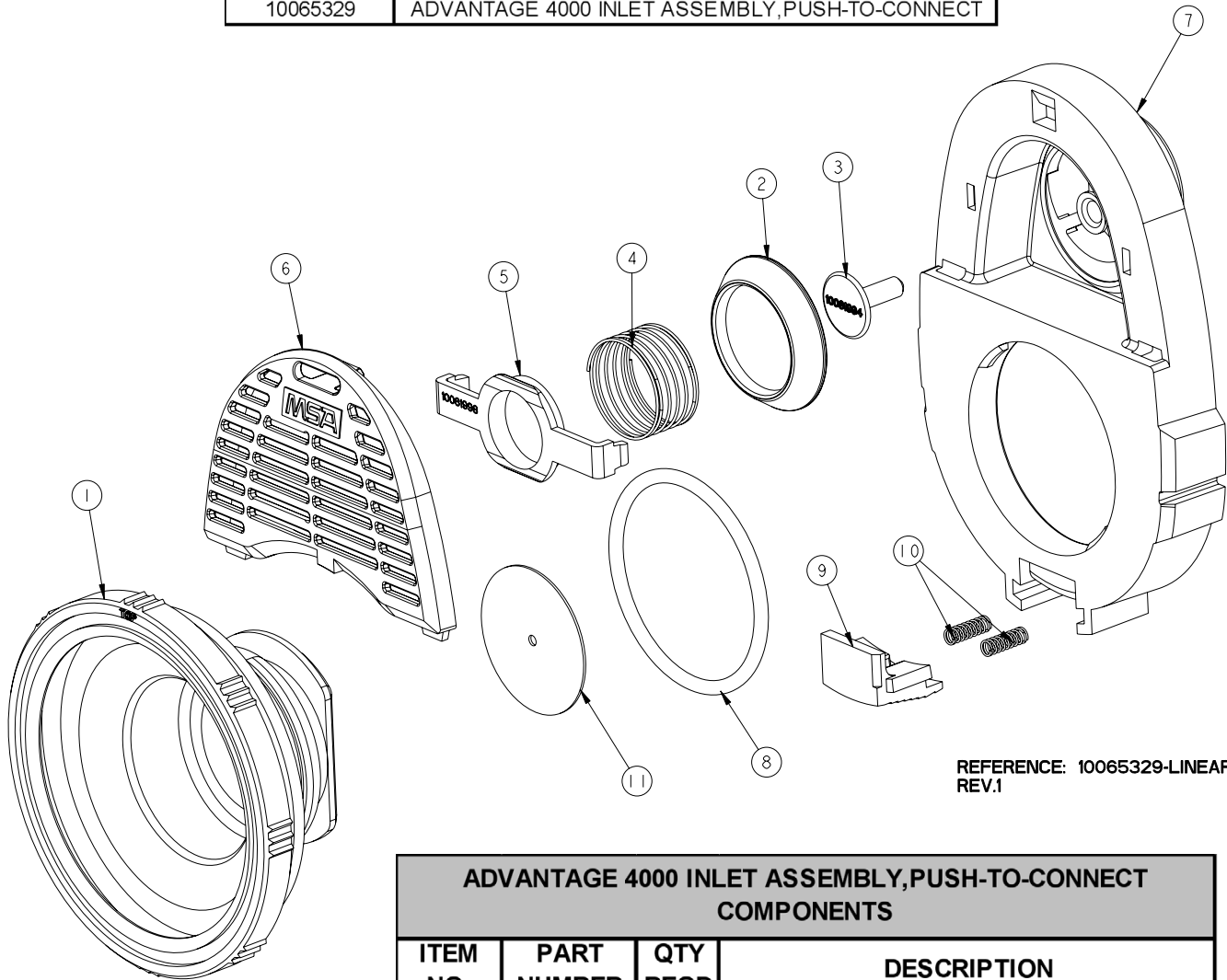

REFERENCE: 10065329-LINEART
REV.1

ADVANTAGE 4000 INLET ASSEMBLY, PUSH-TO-CONNECT COMPONENTS			
ITEM NO.	PART NUMBER	QTY REQD	DESCRIPTION
1	10061978	1	ADAPTER
2	10061995	1	VALVE, EXHALATION
3	10061994	1	STEM
4	10081456	1	SPRING, EXHALATION
5	10061998	1	RETAINER, SPRING
6	10061974	1	COVER, EXHALATION
7	10077331	1	HOUSING, COMPONENT
8	10065301	1	ORING, #128
9	10061976	1	BUTTON, LOCKING
10	10065303	2	SPRING
11	10065805	1	VALVE, INHALATION
NOT SHOWN	604070	-	LUBRICANT

ADVANTAGE[®] 4000

ADVANTAGE 4000 ASSEMBLY	
PART NUMBER	DESCRIPTION
10065328	ADVANTAGE 4000 INLET ASSEMBLY, TWIN-CARTRIDGE

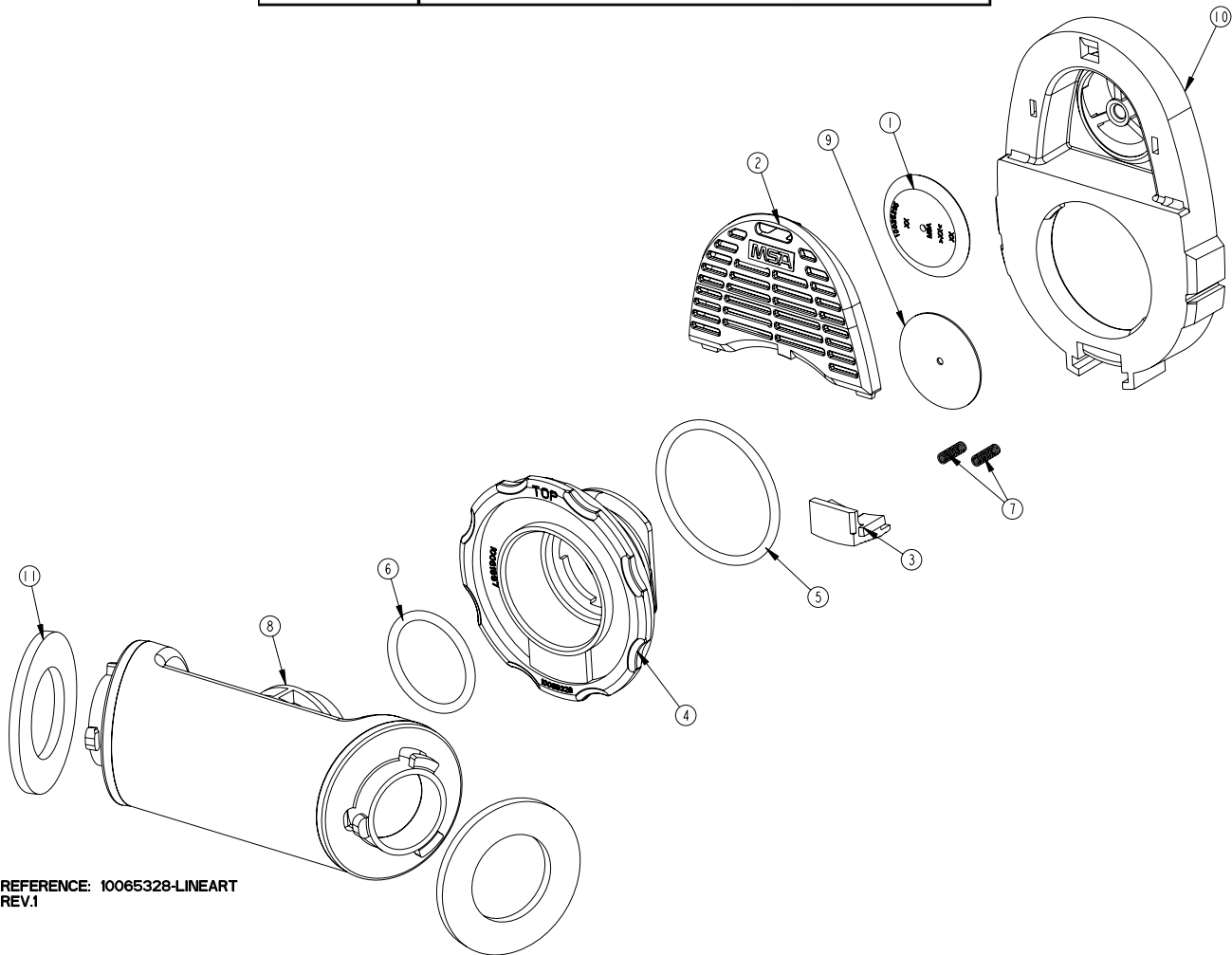

REFERENCE: 10065328-LINEART
REV.1

ADVANTAGE 4000 INLET ASSEMBLY, TWIN-CARTRIDGE COMPONENTS			
ITEM NO.	PART NUMBER	QTY REQD	DESCRIPTION
1	10025295	1	VALVE, EXHALATION, PUSH-ON
2	10061974	1	COVER, EXHALATION
3	10061976	1	BUTTON, LOCKING
4	10061997	1	HANDWHEEL
5	10065301	1	ORING, #128
6	10065302	1	ORING, #120
7	10065303	2	SPRING
8	10065333	1	TWIN CARTRIDGE ASSY W/BAYONET CAPS
9	10065805	1	VALVE, INHALATION
10	10061975	1	HOUSING, COMPONENT
11	10018496	2	GASKET, BAYONET
NOT SHOWN	604070	-	LUBRICANT

ADVANTAGE[®] 4000

ADVANTAGE 4000 ASSEMBLY	
PART NUMBER	DESCRIPTION
10065330	ADVANTAGE 4000 INLET ASSEMBLY,RD40

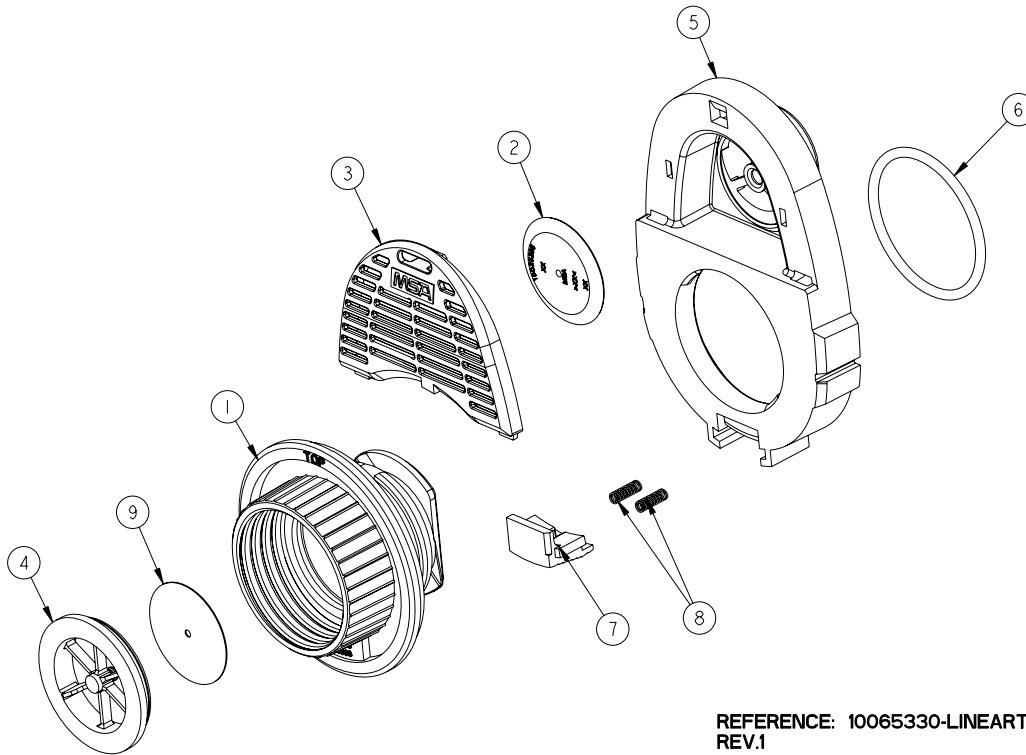

REFERENCE: 10065330-LINEART
REV.1

ADVANTAGE 4000 INLET ASSEMBLY,RD-40 COMPONENTS			
ITEM NO.	PART NUMBER	QTY REQD	DESCRIPTION
1	10065336	1	ADAPTER
2	10025295	1	VALVE, EXHALATION
3	10061974	1	COVER, EXHALATION
4	10025292	1	GASKET, SPIDER
5	10061975	1	HOUSING, COMPONENT
6	10065301	1	ORING, #128
7	10061976	1	BUTTON, LOCKING
8	10065303	2	SPRING
9	10065805	1	VALVE, INHALATION
NOT SHOWN	604070	-	LUBRICANT



For More Information, call 1-800-MSA-2222 or Visit Our Website at www.MSAafety.com

MINE SAFETY APPLIANCES COMPANY
CRANBERRY TWP., PENNSYLVANIA, U.S.A. 16066