

FL500 UV/IR FLAME DETECTOR



FL500 UV/IR FLAME DETECTOR

RELENTLESS PROTECTION
OVER WHAT MATTERS MOST

UV/IR TECHNOLOGY

A UV/IR flame detector combines an ultraviolet sensor for quick response and an infrared detector that monitors radiation emitted by a flame. This combination offers increased immunity, operates at faster speeds, and is suited for both indoor and outdoor use.

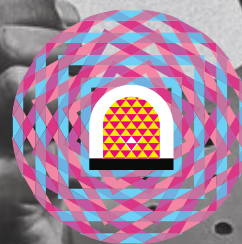

FALSE ALARM IMMUNITY

The FL500 UV/IR detector is designed to detect fires while maintaining false alarm immunity.



HIGH SPEED

Designed to detect fires and provide a fast response.



FOR YOUR WORKSITE

We are dedicated to offering flame detection solutions that always have your worksite in view and keep operations moving.

Rugged stainless
steel enclosure

Self-check feature

IR detector

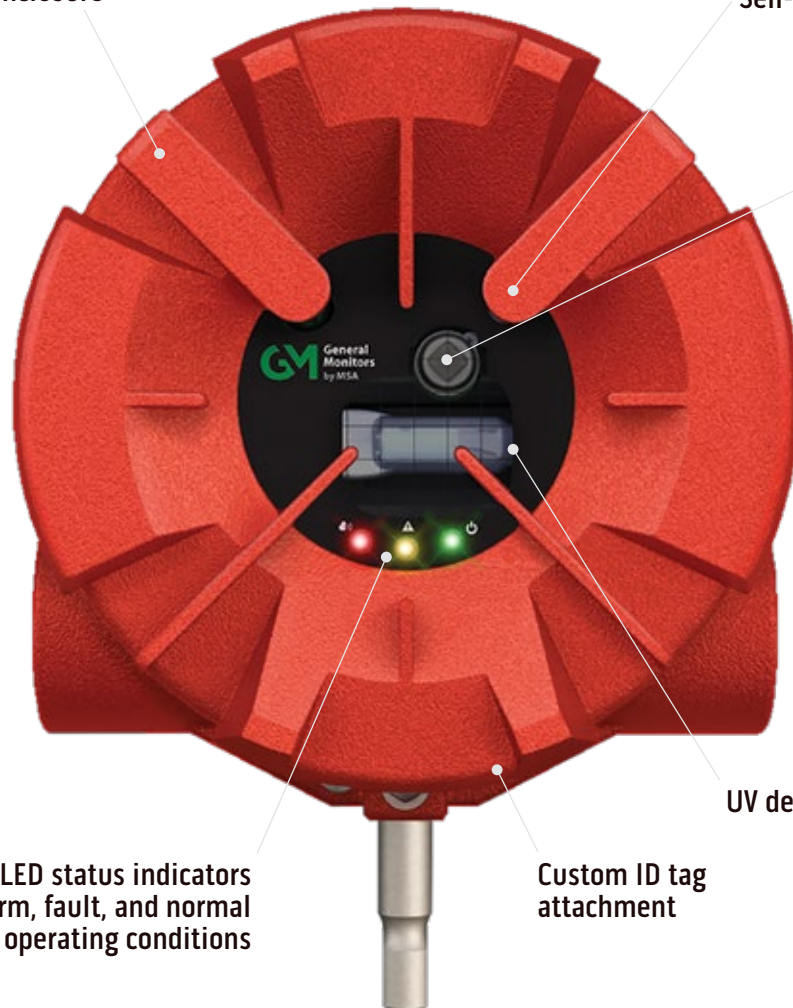

UV detector

Three LED status indicators
for alarm, fault, and normal
operating conditions

Custom ID tag
attachment

IMPROVED DESIGN

Newly designed with a stainless steel housing
and three LED indicators that are always in view.

SAFETY INTEGRITY SELF-CHECK

Automated self-check of the optical path and electronic circuitry for worry-free operation.

We operate at the highest reliability standards, giving you peace of mind. Every two minutes, a built in self-check known as Continuous Optical Path Monitoring (COPM) performs an optical and electrical check. The self-check routines are designed to ensure the optical path is clear and the electronic circuitry is operational.

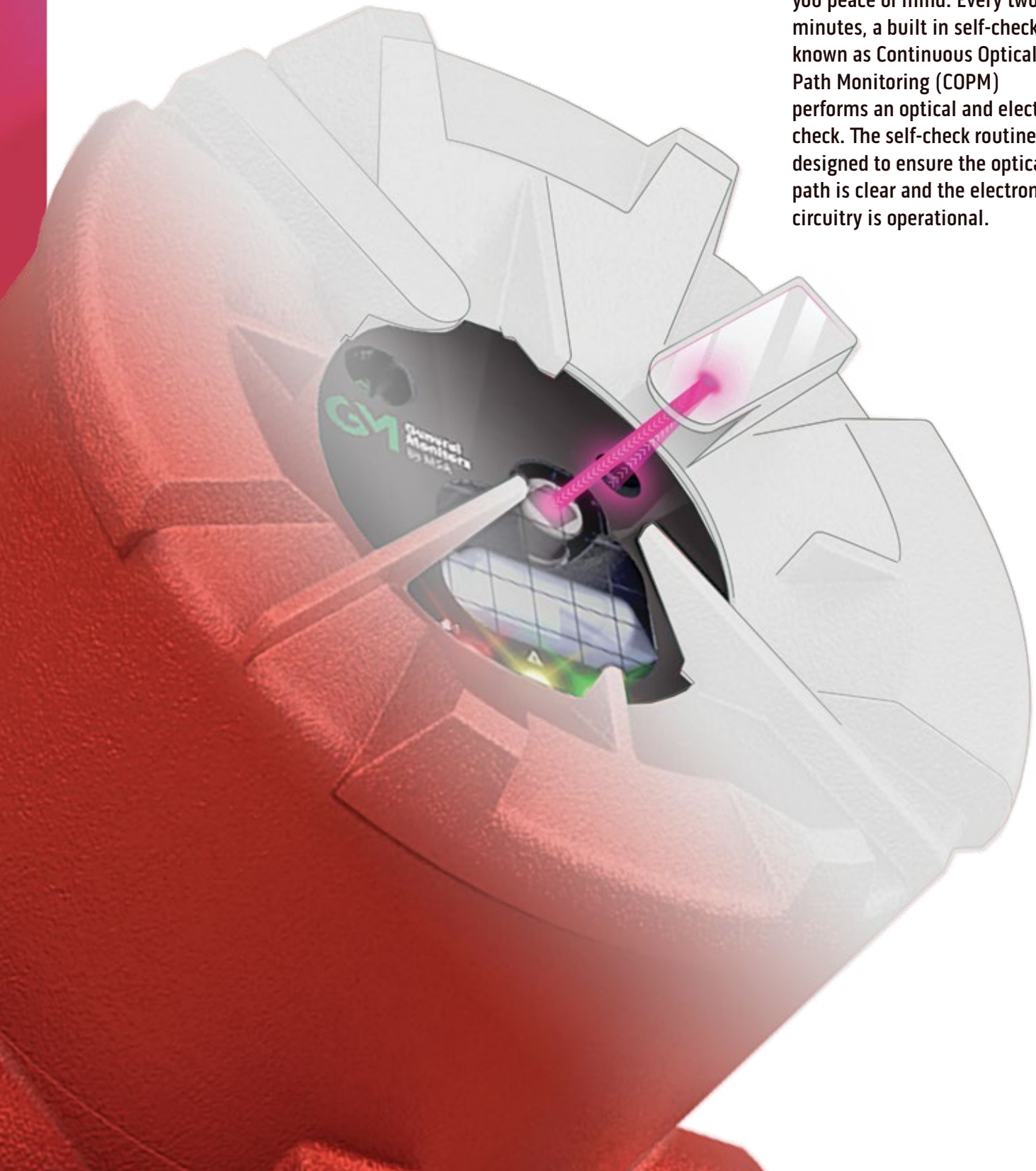

TEST ANYTIME, ANYWHERE

Safely test your flame detector to ensure proper function and operation of your complete detection system.

The FL500 can be tested with the explosion proof TL105 Test Lamp, which simulates the flickering of a fire and provides a high-energy, broadband radiation source that emits energy in both the ultraviolet and infrared spectra to safely activate our flame detectors.

This allows the detector to be tested under real fire conditions without the associated risk of an open flame.



REDUCED RISK WITH
NO OPEN FLAME

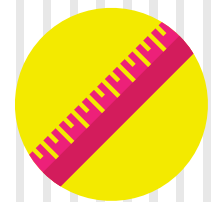

WORKS 15-25 FEET AWAY



RELIABLE TESTING,
ANYTIME



TL105 Test Lamp



PERFORMANCE APPROVED DETECTION

BUTANE

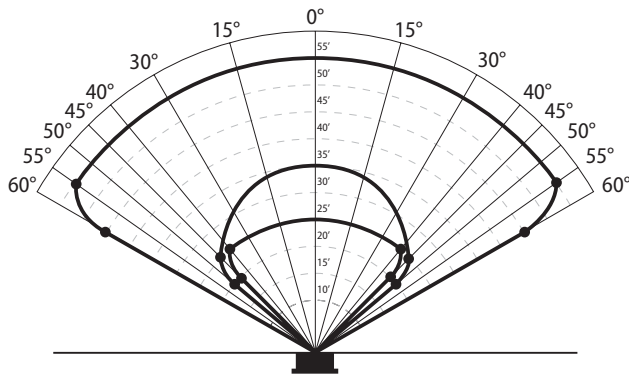

HORIZONTAL	HIGH	MID	LOW
0°	55'	35'	25'
±40°			25'
±45°		25'	20'
±50°		20'	
±55°	55'		
±60°	45'		

ETHANE

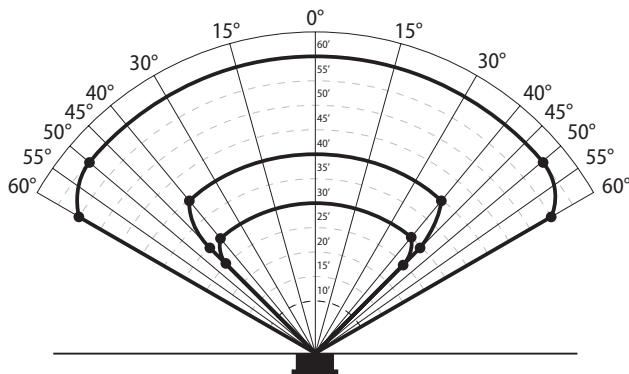

HORIZONTAL	HIGH	MID	LOW
0°	60'	40'	30'
±40°		40'	30'
±45°		30'	25'
±50°	60'		
±60°	55'		

HEPTANE

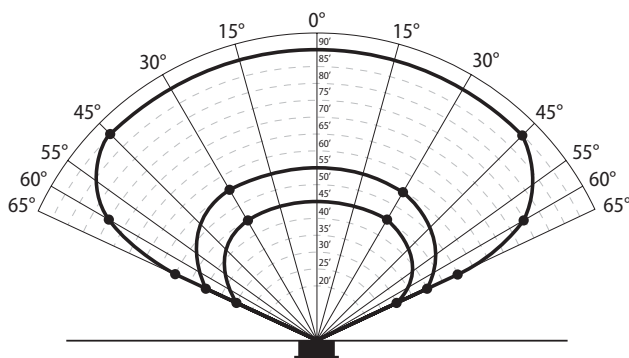

HORIZONTAL	HIGH	MID	LOW
0°	90'	55'	45'
±30°		55'	45'
±45°	90'		
±60°	75'	50'	35'
±65°	50'	40'	30'

HYDROGEN

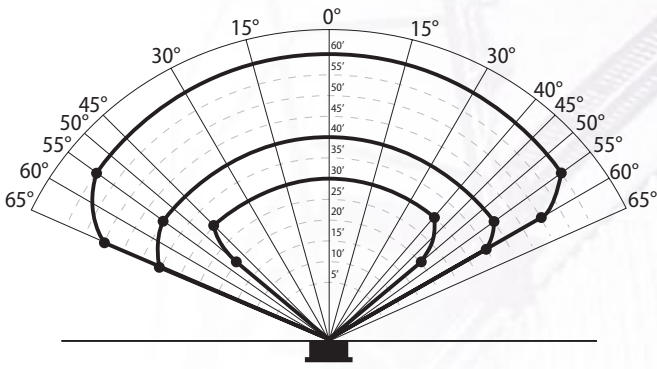

HORIZONTAL	HIGH	MID	LOW
0°	60'	40'	30'
±30°	60'	40'	30'
40°			30'
45°	60'	40'	
-45°	60'	40'	30'
±50°			20'
±55°	60'	40'	
60°	50'	35'	
-65°	50'	35'	

METHANE

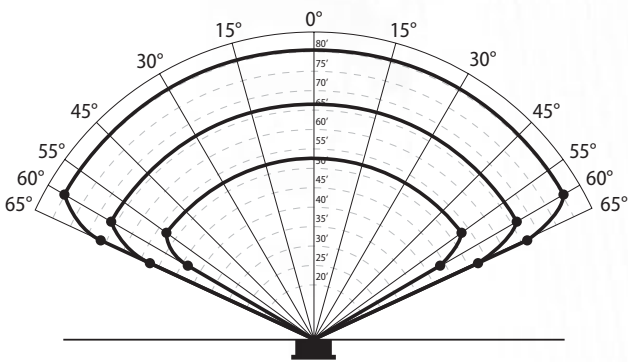

HORIZONTAL	HIGH	MID	LOW
0°	80'	60'	45'
±45°	80'		
±55°	65'	50'	45'
+60°		40'	35'
-60°		35'	35'

METHANOL

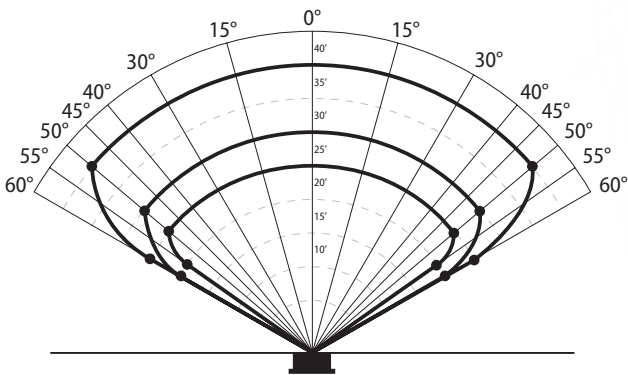

HORIZONTAL	HIGH	MID	LOW
0°	40'	30'	25'
±50°	40'	30'	25'
±55°			20'
±60°	25'	20'	

PROPANE

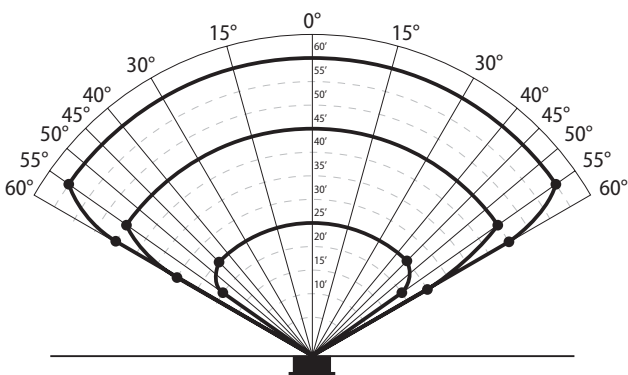

HORIZONTAL	HIGH	MID	LOW
0°	60'	45'	25'
±45°			25'
±55°	60'	45'	20'
+60°	45'	25'	
-60°	45'	30'	

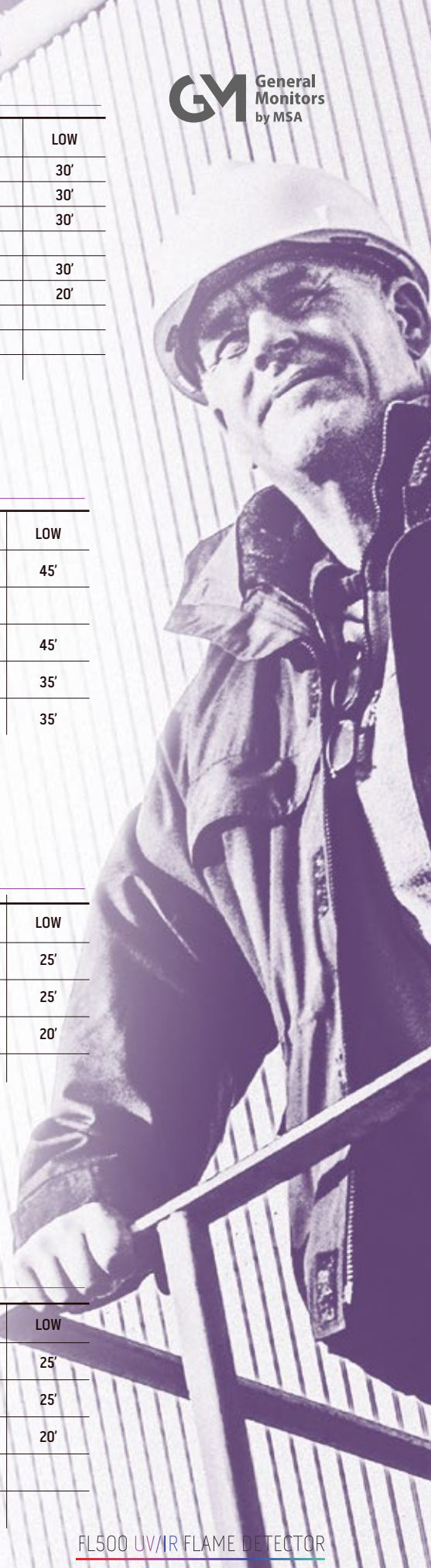

FL500 UV/IR FLAME DETECTOR



SYSTEM SPECIFICATIONS

Wave Lengths	185 to 260 nm (UV) 4.35 microns (IR) 2.95 microns (IR-H2 only)	
Field of View	Up to 130° max. conical	
Fuel	Distance – ft. (m)	Response Time (s)
n-Heptane	90 (27)	6.0
n-Heptane	60 (18)	< 3.0
Methanol	40 (12)	12.0
Methane	80 (24)	< 10.0
Propane	60 (18)	< 7.0
Butane	55 (17)	< 6.0
Ethane	60 (18)	< 3.0
Hydrogen	60 (18)	< 3.0
Accessories	Test lamp	
Classification	Class I, Div 1, Groups A*, B, C, D; Class II, Div 1, Groups E, F, G; Class III, Type 6P Ex db IIC T5 Gb; Ex tb IIIC T100°C Db II 2 G D IP66/IP67	
Warranty	Three Years	
Approvals	CSA, FM, ATEX, IECEx, INMETRO, CE Marking (FL500) CSA, FM, ATEX, IECEx, INMETRO, CE Marking (FL500-H2) Compliance to CPR through EN 54-10 HART 7 registered, SIL 3 suitable	

ENVIRONMENTAL SPECIFICATIONS

Operating Temperature Range	-67°F to +185°F (-55°C to +85°C)
Storage Temperature Range	-40°F to +185°F (-40°C to +85°C)
Operating Humidity Range	0% to 95% RH, non-condensing

MECHANICAL SPECIFICATIONS

Housing	316 Stainless Steel, powder coated
Diameter	4.5" (114 mm)
Length	5.5" (140 mm)
Weight	9 lb. (4.0 kg)
Mounting	Stainless steel mounting bracket
Cable Entry	2 x 3/4" NPT or 2 x 25 mm
Standard Configuration	FL500-5-5-1-2-1-1-1 1.25 mA HART, source current, relays, Modbus, high sensitivity, 4 sec. delay, 3/4" NPT, mounting bracket

ELECTRICAL SPECIFICATIONS

Input Power	20-36 VDC 200 mA max. current (3 W max. power consumption)
Typical Current	80 to 150 mA
Analog Output	Source or Sink
Analog Signal	0-20 mA
Fault Mode	0-0.2 mA**
COPM Self-Check Fault	2 mA, ± 0.2 mA***
Ready Signal	4 mA, ± 0.2 mA
IR Signal	8 mA, ± 0.2 mA
UV Signal	12 mA, ± 0.2 mA
Alarm Low	16 mA, ± 0.2 mA
Alarm High	20 mA, ± 0.2 mA
Relay Contact Rating	5 A 250 VAC, 5 A @ 30 VDC resistive (North America), 5 A @ 30 V RMS/42.4 V peak, 5 A @30 VDC resistive (Europe)
Dip Switch Selectable Options	Sensitivity High, Medium, Low Time Delay Alarm High 2, 4, 8, or 10 seconds Alarm Low & Alarm High Relays Latching/Non-Latching Energized/De-Energized
RS-485 Output	Modbus RTU, suitable for linking up to 128 units or up to 247 units with repeaters.
BAUD Rate	2400, 4800, 9600, or 19200 BPS
HART	Fully HART 7 FieldComm compliant
EMC	Complies with EN 50130-4, EN 61000-6-4
Cable Requirements	Screened or screened and armored to BS5308 Part 2, Type 2, or equivalent.
Status Indicator	3 LEDs with status, fault, and alarm conditions
Faults Monitored	Memory checksum, reset line shorted, optics blockage, internal voltages, and low supply voltage

* Applicable to FM approval only

** Under HART, current values can be either 3.5 mA or 1.25 mA, depending on user selection

*** Under HART, current values can be either 3.5 mA or 2.0 mA, depending on user selection

Note: This Bulletin contains only a general description of the products shown. While product uses and performance capabilities are generally described, the products shall not, under any circumstances, be used by untrained or unqualified individuals. The products shall not be used until the product instructions/user manual, which contains detailed information concerning the proper use and care of the products, including any warnings or cautions, have been thoroughly read and understood. Specifications are subject to change without prior notice.

MSA operates in over 40 countries worldwide. To find an MSA office near you, please visit [MSAsafety.com/offices](https://www.MSA.com/offices).