

User Instructions
V-TEC® io1
Fall Protection



Order No.: 10215637_r0

Print Spec: 10000005389 (R)

CR: 800000043205

⚠ WARNING!

Read this manual carefully before using or maintaining the device. The device will perform as designed only if it is used and maintained in accordance with the manufacturer's instructions. Otherwise, it could fail to perform as designed, and persons who rely on this device could sustain serious injury or death.

The warranties made by MSA with respect to the product are voided if the product is not installed and used in accordance with the instructions in this manual. Please protect yourself and your employees by following the instructions.

Please read and observe the WARNINGS and CAUTIONS inside. For additional information relative to use or repair, call 1-800-MSA-2222 during regular working hours.

MSA is a registered trademark of MSA Technology, LLC in the US, Europe and other Countries. For all other trademarks visit <https://us.msasafety.com/Trademarks>.

This device complies with part 15 of the FCC Rules. Operation is subject to the following two conditions: (1) This device may not cause harmful interference, and (2) this device must accept any interference received, including interference that may cause undesired operation.

You are cautioned that changes or modifications not expressly approved by the party responsible for compliance could void the user's authority to operate the equipment.

English:

This device complies with RSS-210 of the Industry Canada Rules. Operation is subject to the following two conditions: (1) This device may not cause harmful interference, and (2) this device must accept any interference received, including interference that may cause undesired operation.

French:

Ce dispositif est conforme à la norme CNR-210 d'Industrie Canada applicable aux appareils radio exempts de licence. Son fonctionnement est sujet aux deux conditions suivantes: (1) le dispositif ne doit pas produire de brouillage préjudiciable, et (2) ce dispositif doit accepter tout brouillage reçu, y compris un brouillage susceptible de provoquer un fonctionnement indésirable.



The Safety Company

1000 Cranberry Woods Drive
Cranberry Township, PA 16066
USA
Phone: 1-800-MSA-2222
Fax: 1-800-967-0398

For your local MSA contacts please go to our website www.MSAsafety.com

Contents

- 1 Safety Regulations 4**
 - 1.1 Correct Use 4
 - 1.2 Warnings 4

- 2 Description 5**
 - 2.1 Physical Contents 5

- 3 Specifications 7**
 - 3.1 Physical Specifications 7
 - 3.2 Electrical Specifications 8

- 4 Installation 8**
 - 4.1 Installing the V-TEC io1 8
 - 4.2 Installing the RFID Tag 11

- 5 Operation 12**
 - 5.1 Using the V-TEC io1 System 12
 - 5.1.1 Connecting the V-TEC io1 system to the D-ring 12
 - 5.1.2 Sleep Mode 13
 - 5.1.3 Battery Service Life 13
 - 5.1.4 Charging the io1 13
 - 5.2 Status Indicators 13

- 6 Inspection 14**

- 7 Troubleshooting 14**

- 8 Warranty 15**

1 Safety Regulations

1.1 Correct Use

The V-TEC io1 is intended for use as part of a complete personal fall protection system.

The V-TEC io1 is intended to provide audible and visual feedback to users, relaying the connection status of their personal protective equipment (PPE).

The V-TEC io1 is intended for use on Order Picker-type Powered Industrial Trucks (PITs) with overhead-mounted personal fall limiters (PFLs).

WARNING!

Use in applications other than overhead-mounted on an Order Picker-type PIT may result in the io1 remaining asleep and not alarming. Do NOT use in other applications.

Failure to follow this warning can result in serious personal injury or death.

1.2 Warnings

WARNING!

- Device is not Intrinsically Safe. Do NOT use this device in flammable or explosive environments.
- Use the io1 only with the MSA V-TEC PFL and an MSA harness with the RFID tag installed. Do NOT attach to other products.
- Read the V-TEC PFL manual, P/N 63011-96, for instructions and warnings on use of the V-TEC PFL to which the io1 is connected.
- Do NOT alter this equipment or intentionally misuse it. Do NOT use fall protection equipment for purposes other than those for which it was designed. Do NOT use fall protection equipment for towing, hoisting, or material handling.
- Only MSA or persons or entities with written authorization from the manufacturer may make repairs to the V-TEC io1 system. No unauthorized repairs, modifications, alterations, and/or additions are permitted.
- The V-TEC io1 system is only to be used for its intended purpose and within its limitations. Further clarification can be obtained from MSA.
- The io1 must be protected from sharp edges, abrasive surfaces, fire, acids, caustic solutions, or temperatures outside the range -40 °C to 54 °C (-40 °F to 130 °F).
- Do NOT rely on feel or sound to verify proper snaphook or carabiner engagement. Do NOT rely on cessation or absence of an alarm to verify proper snaphook or carabiner engagement. Ensure that gate and keeper are closed before use.
- If the V-TEC io1 system is damaged or is subjected to fall arrest forces or impact forces, it must be immediately removed from service and marked as “UNUSABLE” until it has been destroyed.
- If PPE is resold, it is essential that instructions for use, maintenance, and periodic examination are provided in the language of destination.
- Do NOT interfere with or obstruct the alarm lights and sounds.

Failure to follow these warnings can result in serious personal injury or death.

2 Description

The V-TEC io1 system consists of a V-TEC PFL and a permanently integrated io1 component on the snaphook that monitors and communicates connection status between the snaphook and an MSA harness with an RFID tag attached.

This manual covers instructions and warnings on installation of the V-TEC io1 system and use of the io1.

Reference the V-TEC PFL manual, P/N 63011-96, included in the box, for instructions and warnings on use of the V-TEC PFL to which the io1 is connected.

Wake Mode

Motion wakes the io1 from sleep mode. During wake-up, a 15 second countdown to alarm starts and the io1 pulses red LEDs until a connection is made.

If a connection is present when awake, the io1 pulses a green LED to indicate a good connection.

During a connection event, a tri-tone is played to signal connection. No alarms are sounded during the connected period.

If a disconnection occurs when awake, the io1 counts down a timer and goes into alarm sequence. Once the timer expires, the io1 beeps 90 dB alarm sounds and blinks red lights.

See Table 1 for more information on io1 status indicators.

Sleep Mode

The io1 is calibrated to fall asleep when no movement is sensed. This allows the io1 to fall asleep naturally when it should, such as an order picker stepping off of the Order Picker-type PIT and leaving the io1 to rest.

2.1 Physical Contents

Component	Part Number
V-TEC io1	10213901 (non-swivel snaphook) 10213902 (swivel snaphook)
Charging Line Components <i>includes battery, wires, connector/adapter, cable ties, peel and stick cable tie mounts</i>	10215631
RFID Tag/Screws	10215626
V-TEC PFL User Instructions	63011-96
V-TEC io1 User Instructions	10215637

Figure 1 V-TEC io1 Components

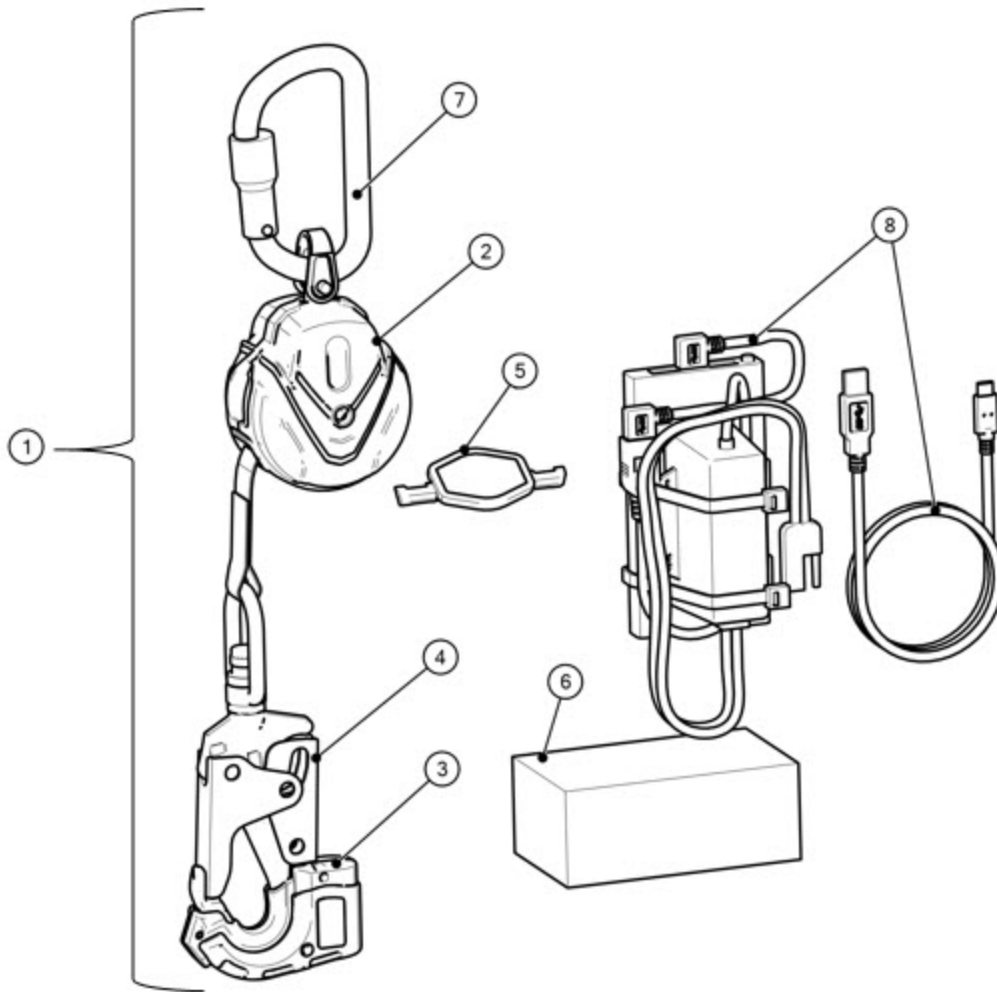

- 1 V-TEC io1 System
- 2 V-TEC PFL
- 3 io1 Component
- 4 Snaphook
- 5 RFID Tag
- 6 Box
- 7 Carabiner
- 8 Charging Kit

Figure 2 Installed RFID Tag

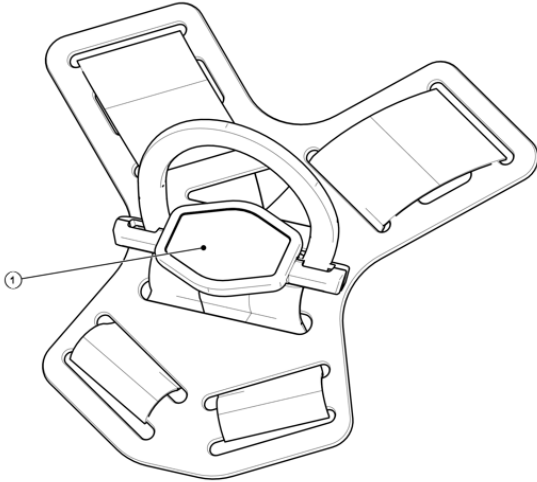

1 RFID Tag

Figure 3 Installed V-TEC io1

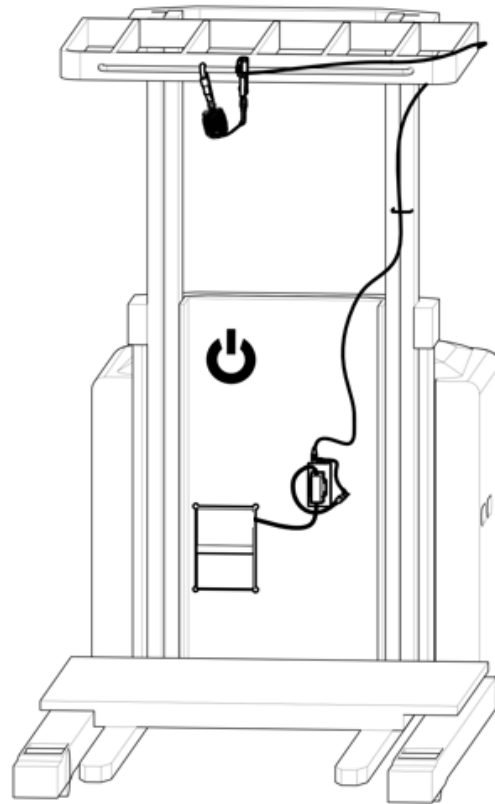

3 Specifications

3.1 Physical Specifications

Capacity	310 lbs (141 kg)
Anchorage Strength	3,600 lbf (16 kN)
Dimensions	13.5" x 3.4" x 2.75"
Product Weight	V-TEC io1 Only: 2.4 lbs Entire Product Kit: 4.8 lbs
Standards	ANSI Z359.14-2014 CSA Z259.2.2-17 OSHA 1910.140, OSHA1926.503
Certifications	FCC Part 15, RSS-210

3.2 Electrical Specifications

Component	Specification	
24V Converter	Input Range:	8V - 40V DC via 16AWG wires
	Output Voltage:	5V DC
	Output Current:	2.5A max
	Output Connection Type:	Female USB Type A
	Operating Temperature:	-10°C to +70°C
	Compliance:	Meets SAE J-1113, Integrated Short Circuit Protection
	Certifications:	FCC, Industry Canada, CE, WEEE, RCM, e-Mark and RoHs Compliant USB 2.0 BC 1.2 DCP Support
USB A to Micro-B Adapter	Interface:	USB 2.0
	Connector 1:	USB Type Micro-B Male
	Connector 2:	USB Type-A Mal
Power Pack	Outputs:	USB-A / 1A and 2.1A
	Inputs:	USB Micro
	Weight:	8.2 oz
	Dimensions:	5.16 x 2.76 x 0.59 inches
10' USB Cable	Interface:	USB 3.0/3.1 Gen 1 (5 Gb/s)
	Connector 1:	USB Type-C Male
	Connector 2:	USB Type-A Male
io1	Input:	USB C 5V
	Battery Capacity:	350mAh LiPo/nom. 3.7V
	Charge Current:	150mA
	Charge Threshold:	35mA

For PFL, Rescue, Training, and Inspection content related to the lanyard itself, please reference included PFL manual, MSA P/N 63011-96.

4 Installation

4.1 Installing the V-TEC io1

WARNING!

- Before wiring the V-TEC io1, disconnect power from the PIT.
- Install wiring in accordance with the electrical code of the country in use, the local authority having jurisdiction, and these installation instructions, as applicable.

Failure to follow these warnings can result in serious personal injury or death.

- (1) Disconnect power from the PIT electrical system.
- (2) Remove the access panel(s) over the control area. Find the open power receptacle and clean as needed.

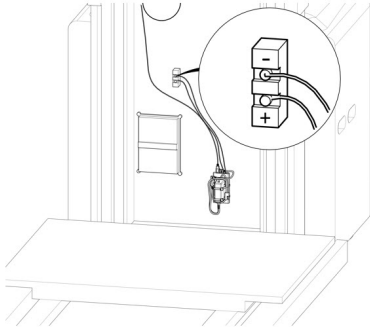

NOTE: Wipe away dust and dirt from the electrical leads with degreaser and a cloth. Inspect the surface for visible dirt or corrosion that may impede electrical contact.

- (3) Plug the input end of the power cord into the available power source. The red-striped wire of the power cord is positive (+) and must be hardwired to a power source of 12-24V. Use any leftover cable clips and cable ties to manage access wires.
 - a) Confirm the supplied io1 power connector will mate with the power receptacle. Each PIT manufacturer has a slightly different preferred location. If unsure where to connect to a hardwired power source on your truck, contact your local PIT authorized service center.

b) Ensure the connector is fully connected and that there are no loose wires.

- (4) Clean the area of attachment for the auxiliary power pack. This should be a flat location on the control wall where the auxiliary battery pack will fit.

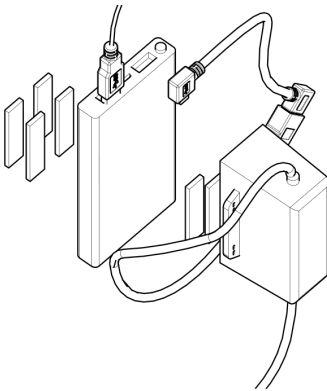

- (5) Mount the combined 24V to USB converter and power pack module to the face of the control wall using the peel and stick foam panel.

Apply pressure to ensure a good adhesion is made. Use zip-ties to add physical restraint, if possible and placement permits.

NOTE: Confirm this location has the required clearance between the control wall and the panel that will be placed over it.

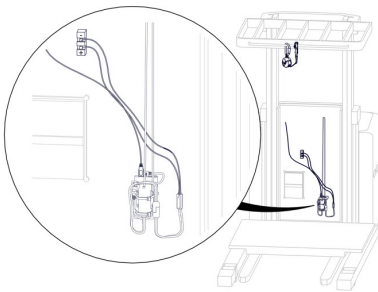

- (6) Mount the V-TEC io1 system onto overhead fall protection rail.

NOTE: Do NOT permanently fix the carabiner in place. It must be able to slide freely.

- (7) Locate a place for the charging line holder on one of the overhead vertical slats that allows the charging line to hang freely.

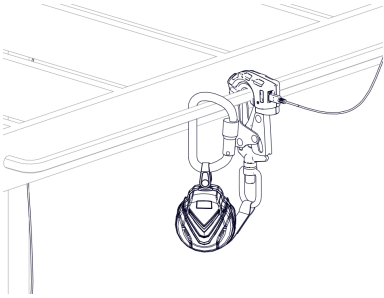

- (8) Connect the 10' USB cable to the USB C port on the back of the io1.

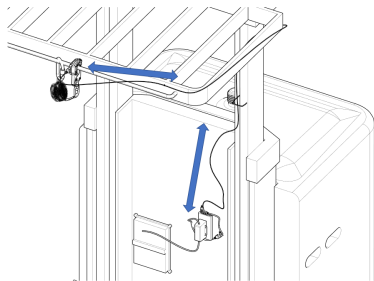

- (9) Route the cable back to the cabin pillar and secure it in the upper corner near the roof leaving some slack in the cable as shown.

NOTE: Use the provided cable ties and peel and stick cable tie mounts as needed.

- (10) Route the USB cable down along the pillar and display post as needed to control the wire path and prevent it from interfering with other components.

NOTE: Use the provided cable ties and peel and stick cable tie mounts as needed.

- (11) Pass the cable down into the open access area and pull all slack cable through to the access area to easily reach the already attached power pack.

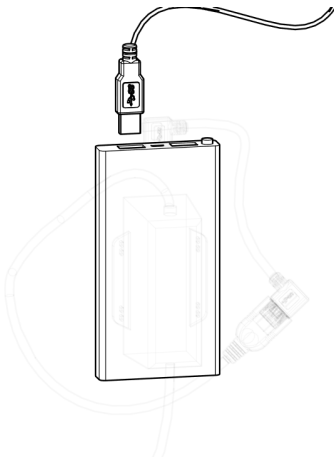

- (12) Connect the USB type A end of the USB cord to the open port on the power pack.

NOTE: Look for the charge LED near the USB-C port on the hook to light either red or green to confirm connection.

- (13) Route the USB cable from the power pack back along the control wall and to the entry point into the access compartment.

NOTE: Use the provided cable ties and peel and stick cable tie mounts as needed to control the wire path and prevent it from interfering with other components.

- (14) Coil any excess wire inside the access area.

NOTE: Use cable ties to secure it so that it does not interfere with any other components or the closing of the access door.

- (15) Disconnect the USB cable from the io1.

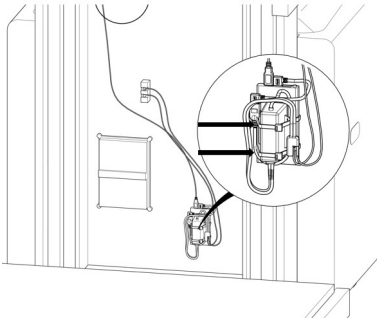

- (16) With the peel and stick cable tie mount attached to the end of the USB cable, select a location near the pillar to affix the peel and stick cable tie mount.

NOTE: This location should be easy for the worker to reach and not allow the stowed cable to interfere with typical picking actions.

NOTE: Wipe the surface clean of grease, dust, debris, or other surface contaminants that may affect adherence of the peel and stick cable tie mount.

- (17) Peel the paper off the peel and stick cable tie mount and firmly stick it to this area.

- (18) Reconnect the PIT electrical system to the battery.

NOTE: Be sure power reaches the power pack by looking for the charging lights on the pack.

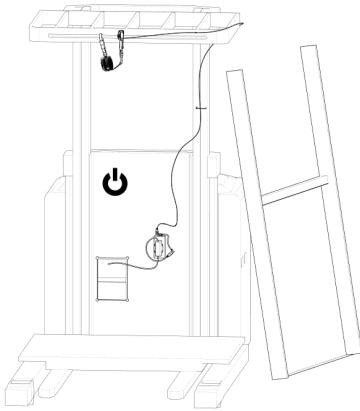

- (19) Replace the access panel(s) over the control area.

4.2 Installing the RFID Tag

- (1) If needed, remove the clasp bar of the V-TEC io1 RFID tag by using a #2 Phillips screw driver.

NOTE: The two assembly screws are captured and should not be fully removed for disassembly.

- (2) Position the main body of the RFID carrier at the center of the base of the D-ring. Ensure the MSA logo is right side up. The recesses in the mounting arms of the RFID carrier body should line up with the sides of the D-ring.
- (3) Hold the main body of the RFID carrier in place and rotate the D-ring and carrier downwards until the back of the carrier is accessible.
- (4) Fit the clasp bar into place. Using a #2 Phillips screwdriver, fasten the clasp bar to the main body of the RFID carrier with the two captured screws.

The D-ring should be facing upward toward the wearer's head for this step.

Ensure the recesses of the RFID carrier arms fully enclose the sides of the D-ring. Do not over-tighten the screws.

5 Operation

WARNING!

- Do NOT use a rechargeable battery that shows signs of damage such as bulging, swelling, leaking fluid, a cracked housing, or broken contacts.
- Do NOT use a rechargeable battery charging system if any component of the system shows damage. Replace the components if they show cracks or distortion, or if the cord shows damage or wear.
- Do NOT attempt to open the housing of the rechargeable battery module. The rechargeable battery module does not have replaceable cells.
- Do NOT dispose of batteries in a fire. Batteries can explode. Dispose of in accordance with local regulations and requirements.
- Use only the MSA rechargeable battery charging system (P/N 10215631) with the io1 rechargeable battery.
- Keep the io1 and rechargeable battery charging system dry. Do NOT disassemble, repair, or alter the io1 or charging system. Do NOT immerse in water or other liquids.
- Only use the io1 in temperatures between 32°F (0°C) and 104°F (40°C).
- Do NOT expose the rechargeable battery or charging system to high temperature or heating equipment including, but not limited to, direct sunlight and water heaters. Overheating may cause an explosion.
- Do NOT drop, crush or puncture the rechargeable battery or charging system. Damage from such occurrences can lead to short-circuit and overheating of the equipment.

Failure to follow these warnings can result in serious personal injury or death.

5.1 Using the V-TEC io1 System

5.1.1 Connecting the V-TEC io1 system to the D-ring

Attach the io1 to the D-ring.

NOTE: When contact is made, the io1 plays a "connection" tri-tone sound and an LED pulses green.

WARNING!

Ensure the io1 turns green.

Failure to follow this warning can result in serious personal injury or death.

If after several tries the io1 is still red when attached to the D-ring, use a paperclip to reset the device or contact MSA Customer Service. See [7 Troubleshooting](#) for more information on resetting the io1.

NOTE: When the io1 wakes up, a 15 second countdown to connect begins. An alarm sounds at 15 seconds if no connection is made.

NOTE: While the io1 and D-ring are connected, the io1 pulses green in 3 second intervals.

NOTE: If the io1 and D-ring become disconnected, a 30 second countdown to reconnect begins. An alarm sounds at 30 seconds if no connection is made.

5.1.2 Sleep Mode

When the io1 does not detect motion, the device enters sleep mode.

The io1 “wakes up” when it detects motion.

5.1.3 Battery Service Life

When the battery has 20% service life remaining, the io1 pulses red at 3 second intervals until it is plugged in to charge.

5.1.4 Charging the io1

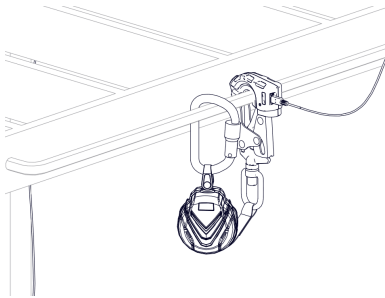

- (1) Park the order picker truck.
- (2) Insert the charging cable into the USB-C port on the io1.
- (3) The LED is red if the battery is less than 90% charged. The LED is green if the battery is at least 90% charged.

When the battery is fully charged, the LED pulses green.

5.2 Status Indicators

Table 1 Status Indicators

Hook Behavior	Occurs When
Initial Turn On/Reset	
Ascending tri-tone followed by visual self test of each LED light	io1 is turned on or reset with the reset button.
While in Use	
Sequence of ascending tones	io1 wakes from sleep mode
Ascending single tri-beep tone	io1 connects with harness tag
Pulsing red LED light	io1 is disconnected
Intermittent pulsing green LED light	io1 is connected
Pulsing red LED light while connected	io1 battery is at 25% or lower
Sequence of descending tones	io1 wakes from sleep mode with a battery at 25% or lower
Descending tri-tone and solid red LED light	io1 is malfunctioning—See 7 Troubleshooting for io1 reset information.
While Charging	
Solid red LED light	io1 battery is less than 90% charged
Solid green LED light	io1 battery is at least 90% charged

WARNING!

Do NOT interfere with or obstruct the alarm lights and sounds.

Failure to follow this warning can result in serious personal injury or death.

6 Inspection

Inspection Component	Inspect For:
io1 case	Inspect for cracks, dents, and chipping.
Alarm sounding hole	Inspect for debris blocking alarm hole (remove if present). Confirm alarm sounds according to status indicators in Table 1 .
Charging line	Inspect charging line and verify they are free of any cuts or abrasions. The cables should be fully secured at the each connection point and there should be no loose portions of wire.
Labels	Inspect labels to ensure they are present and all information is legible. The labels should be free from abrasions or peeling.

See MSA V-TEC PFL Manual, MSA P/N 63011-96 (included in box) for Retractable Lanyard portion.

7 Troubleshooting

If the io1 is not working, perform a hard reset. See Table 1 for status indicators.

Press the reset button on the side of the io1 plastic housing with a small paperclip to turn it off. Do this again to turn the io1 back on.

Figure 4 Reset io1

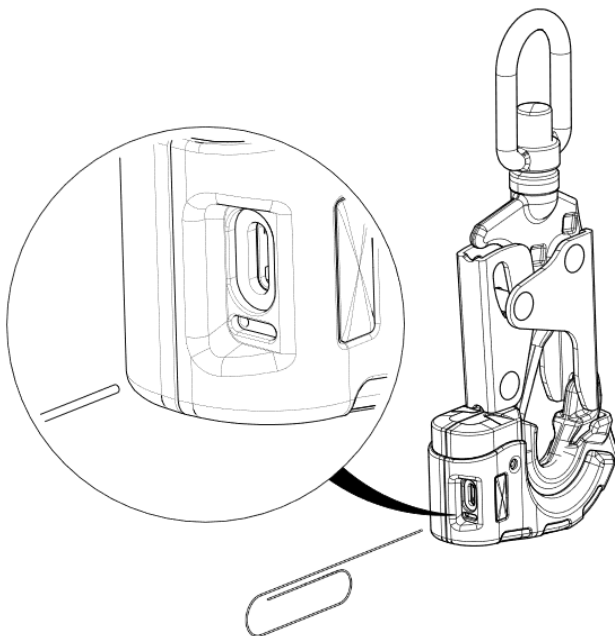

8 Warranty

Express Warranty – MSA warrants that the product furnished is free from mechanical defects or faulty workmanship for a period of one (1) year from first use or eighteen (18) months from date of shipment, whichever occurs first, provided it is maintained and used in accordance with MSA's instructions and/or recommendations. Replacement parts and repairs are warranted for ninety (90) days from the date of repair of the product or sale of the replacement part, whichever occurs first. MSA shall be released from all obligations under this warranty in the event repairs or modifications are made by persons other than its own authorized service personnel or if the warranty claim results from misuse of the product. No agent, employee or representative of MSA may bind MSA to any affirmation, representation or modification of the warranty concerning the goods sold under this contract. MSA makes no warranty concerning components or accessories not manufactured by MSA, but will pass on to the Purchaser all warranties of manufacturers of such components. THIS WARRANTY IS IN LIEU OF ALL OTHER WARRANTIES, EXPRESS, IMPLIED OR STATUTORY, AND IS STRICTLY LIMITED TO THE TERMS HEREOF. MSA SPECIFICALLY DISCLAIMS ANY WARRANTY OF MERCHANTABILITY OR FITNESS FOR A PARTICULAR PURPOSE.

Exclusive Remedy – It is expressly agreed that the Purchaser's sole and exclusive remedy for breach of the above warranty, for any tortious conduct of MSA, or for any other cause of action, shall be the repair and/or replacement, at MSA's option, of any equipment or parts thereof, that after examination by MSA are proven to be defective. Replacement equipment and/or parts will be provided at no cost to the Purchaser, F.O.B. Purchaser's named place of destination. Failure of MSA to successfully repair any nonconforming product shall not cause the remedy established hereby to fail of its essential purpose.

Exclusion of Consequential Damages – Purchaser specifically understands and agrees that under no circumstances will MSA be liable to Purchaser for economic, special, incidental, or consequential damages or losses of any kind whatsoever, including but not limited to, loss of anticipated profits and any other loss caused by reason of the non-operation of the goods. This exclusion is applicable to claims for breach of warranty, tortious conduct or any other cause of action against MSA.

For additional information please contact the Customer Service Department at 1-800-MSA-2222.

