

Abrasi-Blast™ Respirator

INSTRUCTIONS

⚠ WARNING

This manual must be read carefully by all persons who have or will have the responsibility for using or servicing the product. Like any complex piece of equipment, the Abrasi-Blast Respirator from MSA will perform as designed only if it is used and serviced according to the instructions. Otherwise, it could fail to perform as designed, and persons who rely on this respirator could sustain serious personal injury or death.

The warranties made by MSA with respect to the product are voided if the product is not installed, used, and serviced in accordance with the instructions in this manual. Please protect yourself and your employees by following the instructions. Please read and observe the WARNINGS and CAUTIONS inside. For any additional information relative to use or repairs, call 1-800-MSA-2222 during regular working hours.

See separate insert for NIOSH Approval Information: P/N 10122516

For More Information, call 1-800-MSA-2222 or Visit Our Website at www.MSAnet.com



MINE SAFETY APPLIANCES COMPANY
CRANBERRY TWP., PENNSYLVANIA, U.S.A. 16066

INTRODUCTION

TABLE OF CONTENTS

NIOSH Approval Information	2
Special or Critical User Instructions	2
Description	5
Assembling the Respirator	6
Unpacking and Inspection	6
Donning	8
Using the Respirator	12
Removing the Respirator	14
Cleaning and Disinfecting	15

NIOSH APPROVAL INFORMATION

CAUTIONS AND LIMITATIONS

- A- Not for use in atmospheres containing less than 19.5 percent oxygen.
- B- Not for use in atmosphere immediately dangerous to life or health.
- C- Do not exceed maximum use concentrations established by regulatory standards.
- D- Airline respirators can be used only when the respirators are supplied respirable air meeting the requirements of CGA G-7.1 Grade D or higher quality.
- E- Use only the pressure ranges and hose lengths specified in the User's Instructions.
- G- If airflow is cut off, switch to filter and/or cartridge and immediately exit to clean air.
- H- Follow established cartridge and canister change schedules or observe ESLI to ensure that cartridges and canisters are replaced before breakthrough occurs.
- J- Failure to properly use and maintain this product could result in injury or death.
- L- Follow the manufacturer's User's Instructions for changing cartridges, canister, and/or filters.
- M- All approved respirators shall be selected, fitted, used, and maintained in accordance with MSHA, OSHA, and other applicable regulations.
- N- Never substitute, modify, add, or omit parts. Use only exact replacement parts in the configuration as specified by the manufacturer.
- O- Refer to User's Instructions, and/or maintenance manuals for information on use and maintenance of these respirators.
- P- NIOSH does not evaluate respirators for use as surgical masks.
- S- Special or critical User's Instructions and/or specific limitations apply. Refer to User's Instructions before donning.

Maintaining the Respirator	16
Repositioning the Lens Housing Assembly	17
Accessories	18
Abrasi-Blast Hood Styles and Accessories	20
Facepiece Assemblies	21
Flow Control Devices	23
Air-Supply Hoses	25
Quick-Disconnects	26

S - SPECIAL OR CRITICAL USERS INSTRUCTIONS

The wearer must comply with the following MSA respirator use limitations:

1. The limitations outlined in the applicable NIOSH approval.
2. Any applicable limitation contained in a standard established by a regulatory agency (such as OSHA) with jurisdiction over the wearer.
3. Users must wear suitable protective clothing and precautions must be taken so that the respirator is not worn in atmospheres that may be harmful to the device.
 - a. Do not wear for protection against substances with poor warning properties or those which generate high heats of reaction with sorbent material in the filter.
 - b. Make certain conditions of exposure are within the limits for which the device is approved.
4. Refer to Tables 1, 3, and 5 for specific supply hose and pressure limitations for the Abrasi-Blast. Also, for more detailed information, refer to the specific approval label at the end of the configuration.
5. **The Advantage® 4000 Facepiece** is not authorized for use without a noseclip.
6. This approval applies only when the device is supplied with respirable air through 8 to 300 feet of air supply hose within the pressure range of 35 - 40 pounds per square inch gage.
7. A maximum of 12 sections of air supply hose may be used in making up the maximum working length of hose. Each section of coiled hose, regardless of length, is considered 50 feet in length (max.: 6 sections).
8. Below 32° F, add the following noseclips to the Ultravue® Facepiece: 471539, 471540, or 471541.
9. NIOSH approval information is included as a supplement (P/N 10122516) to these instructions for Abrasi-Blast Respirators.

INTRODUCTION

RESPIRATOR USE LIMITATIONS DUO-FLO™ MODE

Maximum Use Concentration — Duo Flo Mode

Do not exceed ANY of the applicable maximum use concentrations listed in Table 1.

Mixtures of Contaminants —

NIOSH allows this respirator to be used for protection against a mixture of contaminants that are present simultaneously or used alternately against one contaminant then another (using the same filters) if the mixture meets the following conditions:

- a. The filter must be approved for all contaminants present.
- b. Contaminants present simultaneously must be below IDLH levels for the specific contaminants. If any one contaminant in the mixture exceeds the IDLH concentration then the entire mixture must be treated as IDLH and the respirator cannot be used (except for escape from particulates with appropriate filter).

Table 1

RESPIRATOR TYPE RESPIRATOR USE	RESPIRATORS WITH PARTICULATE FILTERS OR FILTER CARTRIDGES
Routine Use in Air-Supplied Mode - Including Entry Continuous Use and Non-Emergency Egress	1,000 Times Exposure Limit
Routine Use in Air-Purifying Mode - Including Entry, Continuous Use, Non-Emergency Egress and/or Moving from Station-to-Station	50 Times Exposure Limit
Emergency Escape in Air-Purifying Mode	Unlimited

Exposure Limits for Mixtures

The American Conference of Government Industrial Hygienists (ACGIH) publishes the following information to determine the TLV of a mixture.

First, determine the total concentration of the chemical mixture (C_{Mixture}) from the individual contaminant concentrations ($C_1, C_2, C_3 \dots$) using the following formula:

$$C_{\text{Mixture}} = C_1 + C_2 + C_3 + \dots$$

The TLV of the mixture is found by using the following formula where $T_1, T_2, T_3 \dots$ are the individual contaminant TLVs and C_1, C_2, C_3, \dots are the individual contaminant concentrations:

Only use these equations if the contaminants present are actually mixed. Some substances do not mix and may be present separately, for example, in pockets or at different levels. In that case, the lowest TLV of the substances present must be used to determine the appropriate respirator category for protection against all contaminants present.

Exposure Limits

A listing of acceptable exposure limits from the following sources.

- American Conference of Government Industrial Hygienists (ACGIH)
- Occupational Safety and Health Administration (OSHA)
- National Institute for Occupational Safety and Health (NIOSH)
- American Industrial Hygiene Association (AIHA)

Contact MSA at 1-800-MSA-2222 for information.

DESCRIPTION

The Abrasi-Blast Respirator may be ordered in numerous configurations. To identify the configuration that you have received, match the part numbers of your unit with those listed in Table 2.

You may wish to make a permanent record of your complete system as an aid for ordering replacement parts. Use the listing below to keep a record of your configuration in this manual.

Assembly	Part No.
Hood	_____
Cover Lens	_____
Facepiece	_____
Flow Control Valve	_____
Air-Supply Hose	_____

During abrasive blasting operations, the facepiece lens is protected by two to four flat-glass cover lenses. Each cover lens is removed by two pull-tabs when it becomes so scratched that vision is reduced. Respirator approval requires the use of the proper length of approved air-supply hose, approved fittings, and a respirable air source.

When using the Duo-Flo Respirator, the user breathes through the filter until connecting the air-line. The supplied-air mode of operation may be used for long periods of time without depleting the filter. The air-purifying mode of operation also may be used for extended periods of time when an air source is not available. During use, the respirator remains in the supplied-air mode of operation so long as the user is connected to an air-line air source. The air-purifying mode of operation is entered "automatically" if the air-line air source is disconnected or lost for any reason.

ALL CONFIGURATIONS

Constant Flow Adjustable Valves — Adjustable valves allow the user to vary air flow within NIOSH-required flow rates.

Duo-Flo — The Duo-Flo valve, used in conjunction with the Ultra filter (P/N 816255), enables the user to enter and escape from contaminated atmospheres without using the air-line air supply.

REQUIRED TOOLS

Abrasi-Blast Respirator systems may be assembled with standard tools and materials following good work practices. The assembly tips below may help:

1. All tapered pipe connections should be wrapped with pipe sealing tape (applied one thread back from the end) before assembly.
2. Open-end wrenches and slip-joint pliers should be used to tighten all threaded connections, unless specifically noted otherwise.
3. Test all threaded connections under pressure with a commercial leak-test solution or soapy water. If a leak is detected, locate the source and correct it before using the respirator.

Table 2

SOME STANDARD ABRASI-BLAST RESPIRATOR ASSEMBLIES (Includes one lens cartridge [.12 untempered] and instruction manual)

Abrasive Mask Assy. P/N	Hood		Facepiece (Medium) P/N	Breathing Tube P/N	Belt P/N	Flow Control Assy.		Type Quick-Disconnect	Supply Hose	Union Adapter P/N
	P/N	Style				P/N	Pressure Supply PSI			
468720	468725	Shoulder	472666	470734	9961	463278	10-15	Snap-Tite	Order Sep.	69542
468716	468724	Waist	472666	470734	9961	463278	10-15	Snap-Tite	Order Sep.	69542
468722	468725	Shoulder	472666	470734	9961	460814	35-40	Snap-Tite	Order Sep.	69542
468718	468724	Waist	472666	470734	9961	460814	35-40	Snap-Tite	Order Sep.	69542
10117170	468725	Shoulder	472666	470734	9961	479114	32-37	CEJN	Order Sep.	69542
10117169	468724	Waist	472666	470734	9961	479114	32-37	CEJN	Order Sep.	69542

ASSEMBLING THE RESPIRATOR

UNPACKING & INSPECTION

The Abrasi-Blast Respirator consists of the following sub-assemblies:

- hood
- facepiece
- breathing tube
- support belt
- collar
- lens housing assembly
- waist strap
- adjustable valve-connector or Duo-Flo adapter
- air-supply hose socket assembly
- cover lens cartridge

⚠ CAUTION

Thoroughly inspect the respirator and all components when received and before using. Read and observe all NIOSH approval limitations as they apply to using the Abrasi-Blast Respirator.

Respirator Assembly

Note: Follow the steps below to assemble the respirator. Do not don the respirator until all steps in this section are completed.

1. Install the breathing tube.

Note: The breathing tube may be worn either outside or under the hood. Follow the instructions that apply to assemble the breathing tube.

- a. If the breathing tube is worn outside the hood, locate the 3/4" hole in the front of the hood. Push the male threaded end of the breathing tube through the hole until the hood seals around the tube at the first to sixth corrugation in the breathing tube.



- b. If the breathing tube is worn under the hood, locate the 3/4" metal plug in the collar inside the hood and remove it by stretching the rubber grommet.



- c. Install the plug in the 3/4" hole in the front of the hood by stretching the rubber material.



- d. Push the threaded end of the breathing tube through the hole in the collar until the rubber grommet seals around the breathing tube at the third corrugation.



- e. When using the parka hood (P/N 807592), push the threaded end of the breathing tube through the elastic collar located on the waist area of the hood.
2. Assemble the facepiece to the hood and breathing tube:
 - a. Unfasten the Velcro closure on the collar and insert the facepiece into the hood.

- b. Align the lens housing assembly with the large opening in the hood.



- c. Stretch the rubber front of the hood over the lens housing so that the rubber forms a seal in the channel between the door frame and the lens housing assembly.



COMPONENT ASSEMBLY

d. Refasten the Velcro closure.

e. Attach the breathing tube to the facepiece by threading the coupling nut onto the breathing tube. Be sure the gasket is in the coupling nut. Hand-tighten.



3. Select the proper cover lens for the job. (Use Table 3 as a general guide to choose the cartridge.) A thinner cover lens may not give satisfactory service life because heavy abrasive may wear holes in the lens.

a. To open the lens housing door, grasp the top corner of the plastic door and pull it away from the hood.



b. Open the package of protective lens cartridges.

c. Insert the lens cartridge into the lens housing. The cartridge can be installed so that the pull-tabs are either at the top or the bottom of the lens housing.



NOTE: Be sure the 2 pull-tabs are not caught in the lens door opening.

Table 3

Lens	Type	Type of Service
.090"	untempered	Medium abrasive blasting
.090"	tempered	Medium abrasive blasting and added protection against glass breakage due to rough handling
.120"	untempered	Heavy abrasive blasting

d. Close the lens housing door to force the lens cartridge into place. Pull on the door without flexing the latch to be sure the door is secured.

4. If a filter cartridge is to be used, refer to the *Replacing the Filter Cartridge* section of these instructions.

NOTE: The filter cartridge is not approved for use on the combination Duo-Flo type respirator.

5. Disconnect the socket assembly from the valve-connector body and thread the socket assembly on the air-supply hose.



6. Connect the opposite end of the air-supply hose to a respirable air source.



NOTE: The pressure gauge assemblies listed below are available with fittings. The pressure gauge assembly is connected to the air source where the air-supply hose from MSA is attached.

Part No.	Description
476734	Snap-Tite
476735	Foster
476737	Hansen
476738	CEJN
476739	Foster (w/check valve)
476740	Hansen (w/check valve)

DONNING

DONNING

These steps must be followed each time the respirator is used.

⚠ WARNING

- **This respirator must be used only by trained personnel and according to MSA's instructions.**
- **Do not use the respirator as an underwater device.**
- **Wear impermeable protective clothing if exposed to poisons which can be absorbed by the skin.**
- **Wear appropriate protective clothing to protect your body from rebounding abrasive material.**
- **This system must be supplied with respirable air. See ANSI Z86.1-1973 [Compressed Gas Association Specification G-7.1 for Quality Verification Level (Grade D) Gaseous Air].**

Misuse can result in serious personal injury or death.

SECTION A: CONSTANT FLOW Supplied-Air Type Respirators

1. Be sure that inlet air pressure is set to agree with the valve-connector you are using. Use the information in Table 4 as a guide.

⚠ WARNING

- **The air source must provide at least 4 cubic feet per minute (cfm) to each respirator, and maintain the required inlet pressure range specified in this manual for the specific flow control device selected.**
- **If the air supply pressure is greater than 15 psig, 40 psig, be sure to use a pressure regulator between the air supply and air-supply hose. Adjust the regulator to deliver air at the pressures specified by the valve-connector you are using.**

Misuse can result in serious personal injury or death.

2. Reconnect the socket assembly to the flow control valve (valve-connector), or Duo Flo airline adapter (Constant Flow pictured)



3. Slide the belt clip of the flow control or the Duo-Flow valve over the support belt. Don the support belt and position the valve so that it will be on your left side.
4. Turn the air supply on. Check for leaks with a commercial leak detection solution or soapy water. Tighten connections as required. Turn off the air source.

NOTE: Attach the appropriate filter to the coupling nut at the bottom of the Duo-Flo valve.

5. Turn the back of the hood and collar "inside-out," exposing the facepiece headstraps. The Velcro strip on the collar does not have to be unfastened unless a protective helmet is worn.
6. Adjust the facepiece headstraps so the end tabs are at the buckles.

7. Grip the facepiece between your thumb and fingers with both hands. Insert your chin into the lower part of the facepiece. Pull the facepiece headstraps over your head. Smooth the straps flat against your head.



- a. Support the facepiece by holding the breathing tube at the coupling nut assembly with one hand.
- b. Tighten the lower (neck) straps. Pull the straps straight back, not out.

- c. Tighten the side (temple) straps.



- d. **For the Ultravue Facepiece:** Tighten the top (forehead) strap to position the lens for best vision and to support the weight of the facepiece.
8. Skip section B. Refer to Section C. Air-Tightness Test (Face-to-Facepiece Seal).

DONNING

SECTION B:

Combination Duo-Flo Type Respirators

1. Be sure that inlet air pressure is set to agree with the valve-connector you are using. Use the information in Table 4 as a guide.

⚠ WARNING

The air source must provide at least 4 cubic feet per minute (cfm) to each respirator, and maintain an inlet pressure within the range of 35 - 40 psig for single exhalation valve masks and 32 - 37 psig for dual exhalation valve masks. If the air supply pressure is greater than 40 psig (37 psig for dual exhalation valve masks), be sure to use a pressure regulator between the air supply and air-supply hose. Adjust the regulator to deliver air at 40 psig. Misuse can result in serious personal injury or death.

2. Reconnect the socket assembly to the Duo-Flo valve.
3. Attach the appropriate filter to the coupling nut at the bottom of the Duo-Flo valve.
4. Connect the breathing tube to the opening at the top of the Duo-Flo tube.
5. Turn the back of the hood and collar "inside-out," exposing the facepiece headstraps. The Velcro strip on the collar does not have to be unfastened unless a protective helmet is worn.
6. Adjust the facepiece headstraps so the end tabs are at the buckles.
7. Grip the facepiece between your thumb and fingers with both hands. Insert your chin into the lower part of the facepiece. Pull the facepiece headstraps over your head. Smooth the straps flat against your head.



- a. Support the facepiece by holding the breathing tube at the coupling nut assembly with one hand.
- b. Tighten the lower (neck) straps. Pull the straps straight back, not out.

- c. Tighten the side (temple) straps.



- d. **For the Ultravue Facepiece:** Tighten the top (forehead) strap to position the lens for best vision and to support the facepiece weight.

SECTION C:

Air Tightness Test (Face-to-Facepiece Seal)

⚠ WARNING

If the breathing tube is worn under the hood, move your head from side to side as well as up and down to check for freedom of head movement. If head movement is restricted, or this method compromises the face-to-facepiece seal in any way, wear the breathing tube on the outside of the hood only.

1. **Supplied-Air**

Respirators Only:

Place the palm of your hand firmly over the breathing tube coupling nut or place your thumb over the breathing tube opening inside the coupling nut.



2. **Combination Duo-Flo Type Respirators Only:**

1. Place your hands tightly over the inlet(s) of the filter.
2. Inhale gently so that the facepiece collapses against your face. Hold your breath for 10 seconds.
3. The facepiece should remain collapsed if the seal is air-tight.
4. If the facepiece does not remain collapsed, readjust the head harness straps and re-test.
5. If an air-tight seal cannot be obtained and leakage is not caused by facial seal leakage, check the facepiece and breathing tube for leaks. (See the *Maintaining the Respirator* section). Locate the problem and correct before using the respirator.

DONNING

⚠ WARNING

This device may not seal properly with your face if you have a beard, gross sideburns or similar physical characteristics (see ANSI Z88.2-1980). An improper facial seal may allow non-respirable air to leak into the facepiece, reducing or eliminating respiratory protection. If such conditions exist, YOU, the user, assume all risks of respiratory injury or death which may result. The face-to-facepiece seal must be tested before each use. Misuse can result in serious personal injury or death.

SECTION D:

Respirator Fit Tests

A qualitative or quantitative respirator fit test must be carried out for each wearer of a combination air-supplied and air purifying type respirator. The test shall be performed in the air-purifying mode of operation and is necessary in order to determine the amount of protection the respirator will provide while being used in the air-purifying mode.

Qualitative Test

If the wearer of the respirator passes a qualitative fit test, the respirator can be worn in contaminant (particulate) concentrations up to the maximum use listed in Table 4.

Quantitative Test

If the wearer of the respirator performs a quantitative fit test, the respirator can be worn in contaminant (particulate) concentrations determined by the results of the test, but not to exceed the maximum use listed in Table 4.

In addition to the above limitations, the wearer must not exceed the limitations listed in the applicable NIOSH Approval or any maximum use concentration controlled by OSHA regulations.

⚠ CAUTION

The user assumes all risks of death or serious bodily injury which can result if a fit test is not performed, or if the respirator limitations are not followed.

Respirator fit test and protection factors are explained fully in ANSI Z88.2, "Practices for Respiratory Protection," published by the American National Standards Institute.

Table 4

Facepiece Type	Maximum Use Concentration
Full facepiece	50 times the TLV for the contaminant

SECTION E:

Final Hookup

1. If wearing a protective helmet, see Step 2. Otherwise, proceed as follows:

- Pull the respirator collar down around your neck. The collar is designed to stretch over your shirt or coverall collar to help seal out dust.



- Pull the back of the hood down in place on your shoulders. On the waist-length model, attach the waiststrap loosely to minimize restrictions to head movement.

2. If wearing a protective helmet, you may wish to either remove and reverse the suspension so the bill of the helmet is in the back or wear it in the standard manner with the bill in front.



NOTE: A protective helmet cannot be used with the duck cloth hood.

- Unfasten the Velcro strip on the collar. Don the helmet with the bill to the rear or front.



- Pull the collar down around your neck and fasten the Velcro strip on the collar. The collar should be over your shirt or coverall to help seal out dust.
- Pull the back of the hood down in place on your shoulders. On the waist-length model, attach the waiststrap loosely to minimize restrictions to head

DONNING

movement.

3. Turn the air-supply on.
4. **Constant Flow Type Respirators:** Connect the breathing tube coupling nut to the valve connector. Hand-tighten. Pull on the air-supply hose to test the connection.
5. **Duo-Flo Type Respirators:** Connect the socket assembly to the Duo-Flo valve when it is desired to switch from the air-purifying mode to the supplied-air mode of operation.

All Abrasi-Blast Respirators are equipped with a heavy rubber hood to provide limited protection to the user's head and neck from rebounding abrasive materials. The hood also provides limited protection to the facepiece lens by using removable glass lens covers. For additional specifications of Type "CE" respirators, see Title 42 CFR, Part 84, Subpart J.

Abrasi-Blast Respirators are available in waist, shoulder, and parka models and may be used with the breathing tube outside or under the hood.



Waist Model Tube Out



Waist Model Tube Under



Shoulder Model Tube Out



Shoulder Model Tube Under

USING THE RESPIRATOR

USING THE RESPIRATOR

⚠ WARNING

- Do not use an Abrasi-Blast Respirator if air contaminants are unknown, immediately dangerous to life or health, or you cannot escape without respiratory protective equipment. The supplied-air Abrasi-Blast respirator configuration does not afford respiratory protection if the air supply fails.
- Do not use the Combination Duo-Flo configuration of the Abrasi-Blast respirator in atmospheres containing less than 19.5 percent oxygen, in atmospheres exceeding the limits for which the filter will provide protection.
- Do not use near flame or hot metal, because hood material may burn. The hood material is classified as self-extinguishing as required by Federal Standard 191, Method 5910.
- Do not contact organic-based solvents which may attack the hood material, air-supply hose or other plastic components. A partial list of such solvents is as follows:
 - * Benzene
 - * Methyl Ethyl Ketone (MEK)
 - * Ethylene Dibromide
 - * Tetrahydrofuran (THF)
 - * Ethyl Acrylate
 - * Acetonitrile
 - * Isobutyl Amine
 - * Petroleum-Based Solvents
- Return to a safe atmosphere and discard the respirator immediately if discoloration, crazing, blistering, cracking or other deterioration of the hood material, air-supply hose or other plastic components is observed.

Misuse can result in serious personal injury or death.

Changing Cover Lenses

The outer cover lens should be removed when it gets dirty or scratched. To change the cover lens, grasp one of the pull-tabs on the corners of the lens and pull straight out. The last protective lens in the cartridge has no pull-tab. It is to be kept over the primary lens to protect its surface from abrasive materials.

⚠ CAUTION

DO NOT remove a lens cartridge during abrasive work. The primary lens may be polycarbonate and will scratch easily. If the primary lens is damaged, the entire lens housing assembly must be replaced.

⚠ WARNING

DO NOT remove the facepiece in a contaminated area to replace the lens cartridge. The contaminant will remain in the surrounding air after abrasive blasting. Return to a safe atmosphere before removing the respirator. Misuse can cause inhalation of the contaminant resulting in serious respiratory injury or death.

Supplied-Air Type Respirators:

Adjusting Air Flow on Adjustable Valve Connectors

1. Push in on the adjusting knob, then turn the knob.



2. Turn the knob fully clockwise (up) for minimum air flow.



3. Turn the knob fully counter-clock-wise (down) for maximum air flow.

NOTE: The adjusting knob may vary air flow, but cannot reduce flow below the required minimum 4 cfm rate when the proper pressure is used at the inlet of the air-supply hose from MSA.

Combination Duo-Flo Type Respirators: Converting to Different Modes of Operation

1. When using the respirator in the air-purifying mode of operation, the supplied-air mode is entered when an air-line air supply is connected to the Duo-Flo valve. The air-line inlet pressure must be 35-40 psig for single exhalation valve facepieces and 32-37 psig for dual-exhalation valve facepieces in order to maintain 4 cfm to the facepiece.

USING THE RESPIRATOR

2. When using the respirator in the supplied-air mode of operation, the air-purifying mode is entered when the air-line air supply is disconnected from the Duo-Flo valve. The air-purifying mode is entered “automatically” if the air-line source is lost for any reason.

⚠ WARNING

Return to fresh air immediately if:

- **Leakage is detected by smell, taste, or eye, nose or throat irritation.**
- **High breathing resistance is encountered.**
- **Any feeling of nausea, dizziness or ill-being develops.**

Misuse can result in serious personal injury or death.

REMOVING THE RESPIRATOR

DOFFING THE RESPIRATOR

Removing the Respirator

1. To remove the hood, air supply system and facepiece, return to fresh air and clean the outer surfaces of the respirator before removing the facepiece.
2. Unsnap the waist-strap on the waist-length model.
3. Lift the back of the hood over your head.



4. If wearing a protective helmet, separate the Velcro strips on the hood collar and remove the helmet.
5. Place your finger tips behind the headstraps. Place your thumbs on the buckles. Pull the top of the buckles away from your head. Repeat as needed to loosen the headstraps. Grip the facepiece by the inhalation housing. Pull the facepiece out, then up over your head. To remove the facepiece quickly, pull the facepiece away from your face, then up over your head.
6. Disconnect the air-line quick-disconnect.
7. Turn the air supply off.
8. Disconnect the breathing tube from the flow control valve.



CLEANING AND DISINFECTING

CLEANING AND DISINFECTING

The respirator must be cared for after each use and on a regular maintenance schedule. Thorough maintenance includes cleaning and disinfecting, as well as inspection of components and parts replacement.

1. Remove excess dust from the respirator.
2. Unlatch the lens door.

3. Grasp the foam frame edge of the lens cartridge and carefully pull the cartridge out.



4. Remove the used protective lenses from the hood pocket and dispose of them properly.
5. Clean and disinfect the respirator components after separating them.
 - a. Unzip the collar. The collar may be cleaned in a washer and dryer similar to a conventional garment (110 degrees F maximum water and air temperature).
 - b. Disconnect the breathing tube from the facepiece.
 - c. Separate the facepiece from the hood. Stretch the rubber front of the hood over the lens housing assembly and remove the facepiece.
 - d. Prepare the cleaner, follow the instructions with the Confidence Plus® Cleaning Solution (P/N 10009971).

NOTE: If the Confidence Plus Cleaning Solution is not used, prepare in accordance with the instructions provided with cleaning products.

- e. Submerge the facepiece, hood, and support belt in the solution. Scrub gently until clean.

⚠ CAUTION

Alcohol should not be used as a germicide. It may deteriorate the rubber.

- f. Rinse facepiece and components in clean, warm (110°F), preferably drain to remove the solution, then air-dry.

⚠ CAUTION

If not rinsed thoroughly, cleaning agent residue may irritate the wearer's skin.

- g. Use a damp cloth or sponge saturated with the solution to wipe the breathing tube.

⚠ CAUTION

- **DO NOT force-dry with heat. Temperatures above 110° F may distort or damage parts of this respirator.**
- **The primary facepiece lens may be polycarbonate and may be scratched if rubbed with coarse dry cloth or paper towels.**

- h. Reassemble the respirator and store in a cool, dry place out of direct sunlight. Do not store the respirator or components within or near an area where respirator or components could be exposed to substances that could attack any part, causing the parts NOT to perform as designed and approved.

MAINTAINING THE RESPIRATOR

MAINTAINING THE RESPIRATOR

⚠ CAUTION

Only trained personnel are to maintain the respirator. Use only genuine MSA parts. Do not make repairs or design modifications other than as recommended by MSA or the NIOSH approval will be voided.

Regular maintenance and inspection of components of the respirator are necessary to assure proper protection. In addition, the NIOSH approvals require that you regularly inspect this unit. Parts found to be worn or damaged must be replaced. See the parts list for correct replacement part numbers.

⚠ WARNING

Inspect the respirator after it has been cleaned and sanitized. The respirator must be inspected before it is used again. Misuse can expose the user to contaminants, resulting in serious personal injury or death.

Inspection

1. Check the hood for tears or holes.



2. Check that the metal plug is inserted in the grommet in either the hood or collar.



3. Install a new lens cartridge.

4. Inspect the breathing tube for tears, cracks or other signs of wear or damage.



5. Remove the facepiece exhalation valve cover and check the valve(s) for tears, holes or cracks indicating wear or damage. Check the exhalation valve seat to assure that it is free from debris and has no cracks, scratches or other signs of damage. Replace the cover and spin it to be sure it is secure.
6. **For Advantage 4000 Facepieces:** Remove the facepiece RD40 inlet assembly and check for damage to the o-rings.

Replacing the Filter Cartridge (Air-Purifying Configuration)

The length of time the P100 filter will give protection depends on the concentration of the contaminant and the rate of breathing while in the air-purifying mode of operation. [Service time can be extended by performing an evaluation in the specific workplace setting that demonstrates (a) that the extended use will not degrade the filter efficiency below 95%, or (b) that the total mass loading of the filter is less than 200mg.] When the facepiece is properly adjusted, the following conditions are indications that the filter has served its useful life and should be replaced.

P100 Filter Cartridge	Excessive Breathing resistance upon inhalation
-----------------------	------------------------------------------------

The user should return immediately to fresh air if these conditions develop. Remove the exhausted filter and examine the gasket in the coupling nut making sure it is properly in place before attaching a suitable new filter.

⚠ WARNING

Protection voided if sealing gaskets are not in their proper place. Misuse can result in serious personal injury or death.

⚠ CAUTION

The bottom seal on the filter should be replaced after each use.

REPOSITIONING THE LENS HOUSING ASSEMBLY

Repositioning the Lens Housing Assembly

Ultravue Facepieces: The standard position of the assembly in the facepiece is with the hinge at the bottom. The lens housing may be reversed so that the door opens with the hinge at the top.

Positioning the Assembly

1. Remove the lens housing assembly from the hood.



2. Loosen the two lens retaining ring screws on the facepiece.



3. Remove the lens retaining rings and the retaining lens housing assembly from the facepiece.



4. Reverse the lens housing assembly so that the door hinge is at the top.



5. Re-install the lens retaining rings and screws.
6. Perform the Air Tightness Test. (See Air Tightness Test section).

ACCESSORIES

NOSECUP (for Ultravue Facepieces)

The nosecup is used with the Ultravue (full) facepiece to reduce lens fogging caused by high humidity or temperatures below 32°F. Nosecups are available in small (P/N 471710), medium (P/N 471711), or large (P/N 471712).

Installing the Nosecup

1. Place the nosecup in the facepiece and position it so its rubber ring faces toward the plastic retainer ring.

2. Starting at the top, stretch and push the rubber ring of the nosecup under the plastic retainer ring of the speaking diaphragm assembly.



3. Continue stretching the nosecup ring and work it into place.

SPECTACLE KIT

The spectacle kit is designed to be used by people who wear glasses. The temple bars of conventional glasses stick through the sealing edge of a full facepiece and prevent a proper seal. The kit includes the support assembly, a rubber block, and the spectacle frame. Prescription lenses can be obtained locally or through MSA.

Installing the Kit

1. Hold the support assembly so that the “coated” arms are up and the rubber block is toward the facepiece lens.
2. Squeeze the arms together and insert the assembly into the facepiece.
3. Place the arms against the lens and release them. The ends of the arms also must be against the lens.



Adjusting the Spectacles

1. To move the spectacles closer to your face, pull the frame prongs out of the rubber block.

2. To move the spectacles farther from your face, push the frame prongs into the rubber block.



3. To move the spectacles up or down, slide the rubber block up or down on the support arms.



FILTER CARTRIDGE ASSEMBLY

Filter cartridges are used to remove slight odors from gases or vapors, or to remove dusts, mists, and fumes that may be in the air supply.

When odors of vapors or gases become noticeable, or when breathing resistance becomes uncomfortable, the cartridge must be replaced. Filter cartridges should be checked for flow resistance using the P/N 465783 Filter Resistance Tester from MSA.

The P/N 476089 Cartridge Holder is approved for use with the supplied-air configuration of the Abrasi-Blast Respirator only, when it is equipped with the following filters:

GMA Cartridges approved for respiratory protection against not more than 1000 parts per million of organic vapors. Available in packages of 10 under P/N 464031.

P100 Cartridge approved for respiratory protection against particulates under the 42CFR84 P100 classification (99.97% efficient against all particulate aerosols including oil-based aerosols). Available in packages of ten.

ACCESSORIES

⚠ CAUTION

The P/N 476089 Filter Cartridge Holder is not approved for use with the air-purifying, Combination Duo-Flo configurations of the Abrasi-Blast Respirator.

1. Installing the filter cartridges in the cartridge holder:
 - a. Unscrew the bezel ring.
 - b. Separate the holder halves.
 - c. Screw the filter cartridge in until it is firmly seated on the gasket.
 - d. Place the holder halves together and tighten the bezel ring to assure a good seal at the gasket.
2. Connecting the cartridge holder (with filter cartridge installed) to the respirator:
 - a. Disconnect the breathing tube from the valve-connector.
 - b. Connect the holder's female fitting to the valveconnector.
 - c. Be sure there is a gasket in the breathing tube coupling nut.
 - d. Connect the breathing tube coupling nut to the holder male fitting.
 - e. Position the holder to fit comfortably on your hip.

ABRASI-BLAST RESPIRATOR PARTS

Consult the MSA Safety Equipment Catalog for parts and part numbers.

ABRASI-BLAST HOOD STYLES AND ACCESSORIES

SHOULDER MODEL

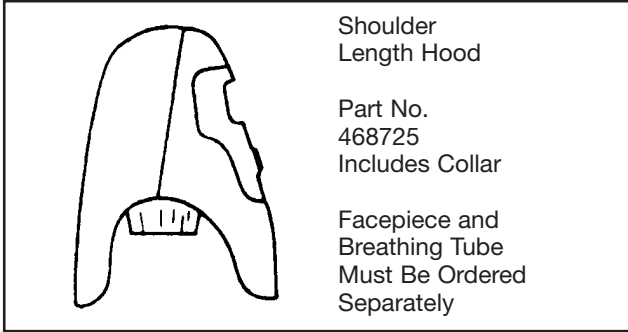

WAIST-LENGTH MODEL

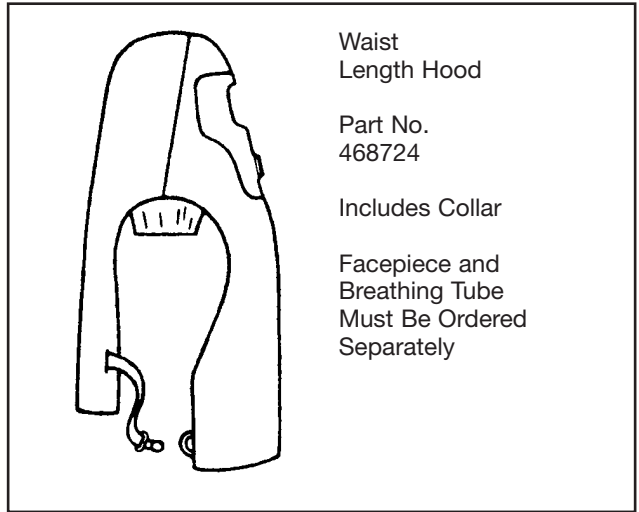

COLLAR ASSEMBLY

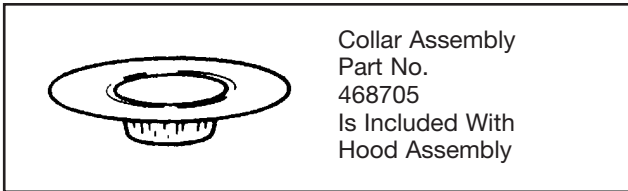

BELT (REQUIRED ACCESSORY)



PLUG

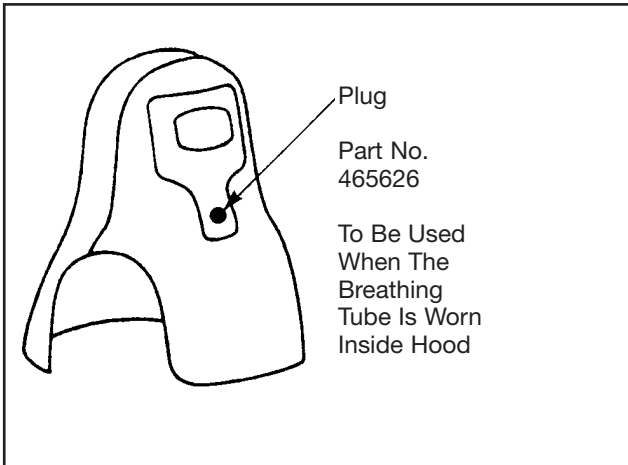

FACEPIECE ASSEMBLIES

PART NUMBER	Demand (Dual Valve)			RUBBER
	SIZE			
	SMALL Model 7-410-2	MEDIUM Model 7-410-1	LARGE Model 7-410-3	
472668	•			•
472666		•		•
472670			•	•

PART NUMBER	Demand (Single Valve)			RUBBER
	SIZE			
	SMALL Model 7-434-2	MEDIUM Model 7-434-1	LARGE Model 7-434-3	
473314	•			•
473312		•		•
473316			•	•

PROTECTIVE LENS CARTRIDGES

Carton of 12 Part Number	Description of Lens	Number of Lens in each Cartridge	Application
473798	.09 thick, untempered	3	Medium abrasive blasting
473800	.09 thick, tempered	3	Medium abrasive blasting with added protection against breakage due to rough handling
10013407	.12 thick, untempered, laminated	1	Heavy abrasive blasting
473802	.12 thick, untempered, 2 layers laminated	2	Heavy abrasive blasting
481742	.12 thick, untempered, 2 layers laminated	3	Heavy abrasive blasting

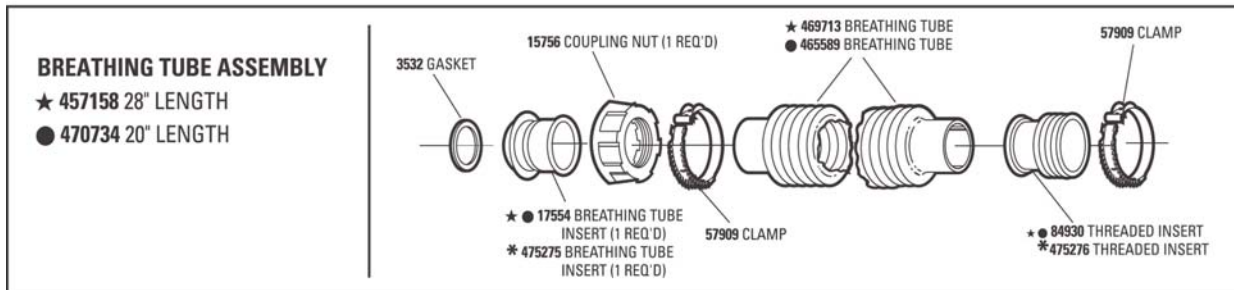
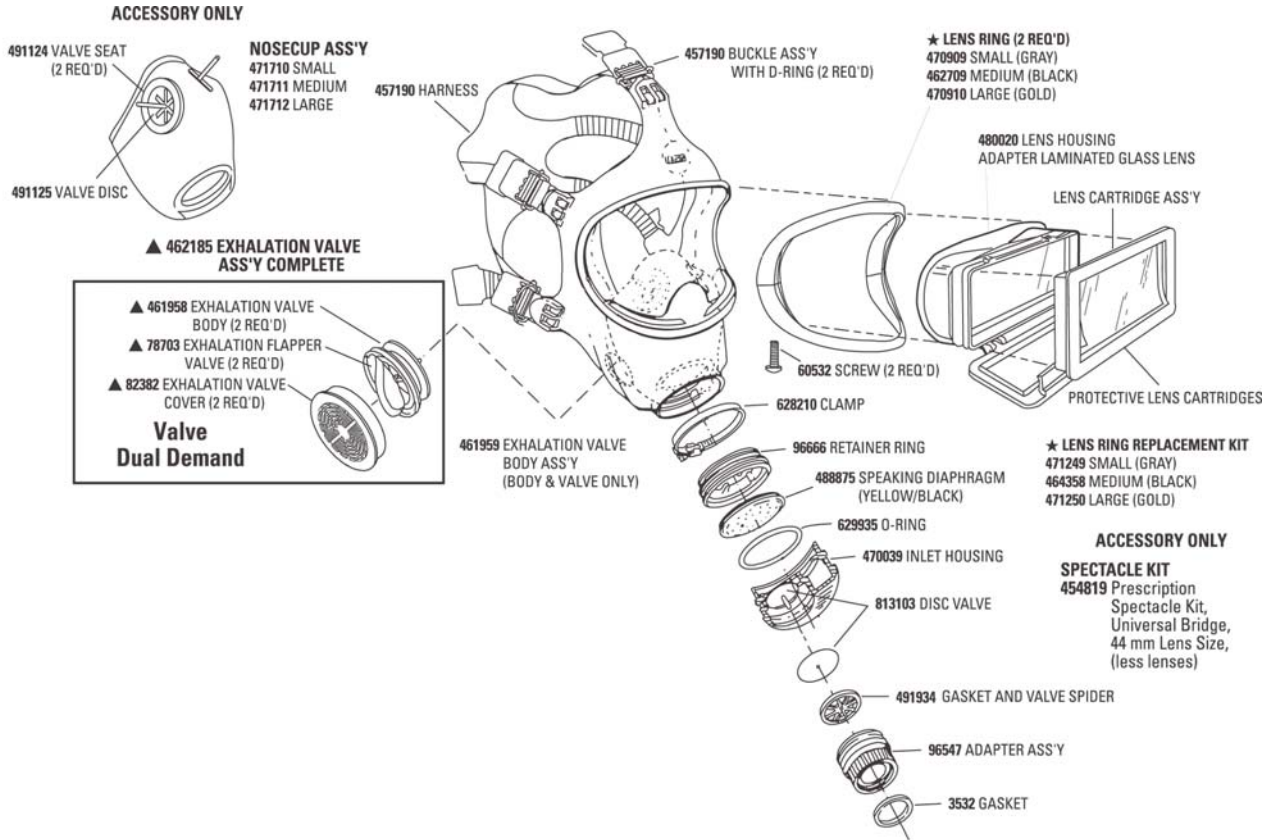

ADVANTAGE 4300 FACEPIECE

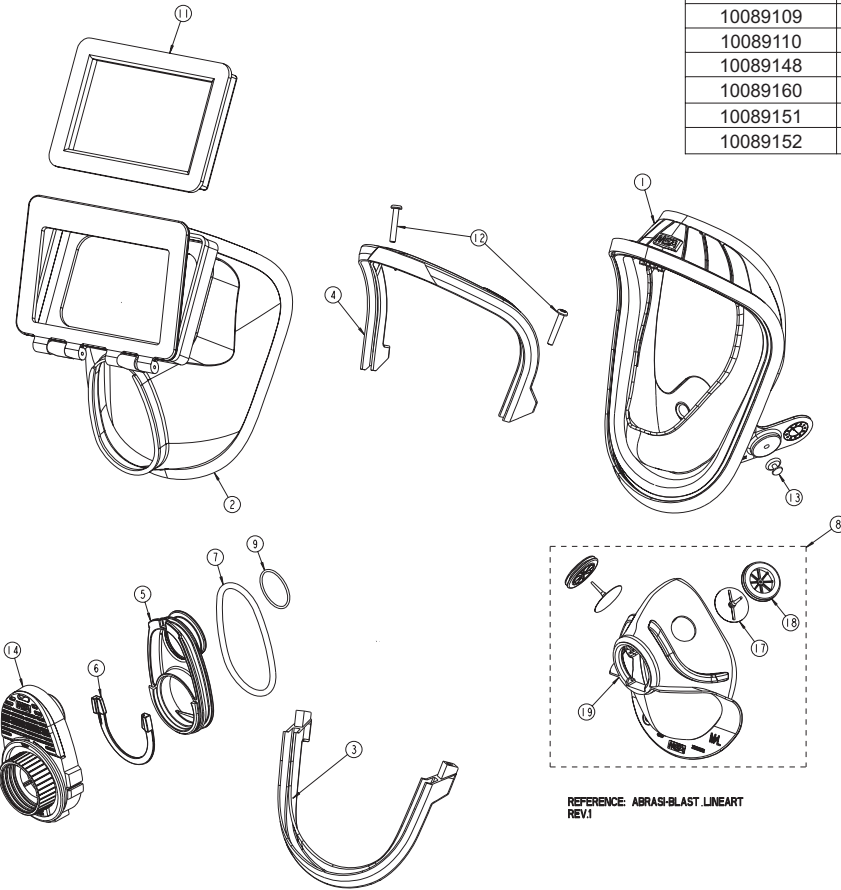

REFERENCE: ABRASI-BLAST LINEART
REV.1

ADVANTAGE 4300 ASSEMBLY	
PART NUMBER	DESCRIPTION
10089109	Facepiece Assembly, Abrasi-Blast, Silicone, Medium
10089110	Facepiece Assembly, Abrasi-Blast, Hycar, Medium
10089148	Facepiece Assembly, Abrasi-Blast, Silicone, Small
10089160	Facepiece Assembly, Abrasi-Blast, Hycar, Small
10089151	Facepiece Assembly, Abrasi-Blast, Silicone, Large
10089152	Facepiece Assembly, Abrasi-Blast, Hycar, Large

ADVANTAGE 4000 TWIN FACEPIECE COMPONENTS				NOSECUP ASSEMBLY COMPONENTS (ITEM #8)			
Item Number	Part Number	Qty. Reqd	Description	Item Number	Part Number	Qty. Reqd	Description
1	10073455	1	Faceblank, Hycar Small	17	304787	2	Disc, Valve
	10073457	1	Faceblank, Hycar, Large	18	491124	2	Seat, Valve
	10073459	1	Faceblank, Hycar, Medium	19	10065305	1	Nosecup, Medium / Large, TPE
	10083926	1	Faceblank, Silicone, Small		10065306		Nosecup, Small, TPE
	10083927	1	Faceblank, Silicone, Medium				
		10083925	1	Faceblank, Silicone, Large			
2a	10065323	1	Advantage 4300 - H				
2b	10091943	1	Advantage 4300 - S				
3	10073461	1	Lens Ring, Lower, Black				
4	10073460	1	Lens Ring, Upper, Black				
5	10061973	1	Housing, Inlet				
6	10061996	1	U-clip				
7	10025297	1	O-ring, Housing, Silicone				
8	10065803	1	Nosecup Assembly, Medium/Large				
	10065804	1	Nosecup Assembly, Small				
9	10084819	1	O-ring, Size 2-024				
11	473238	1	Cartridge, Protective Lens				
	473240						
	473798						
	473800						
	473802						
	481742						
12	10026562	2	Screw, SST, 4m x 25mm, LG, PHIL, PAN HD				
13	10025288	2	Button, Head Harness				
14	10065330	1	Inlet Assembly, RD40				
Not Shown	468724	1	Waist Length Hood				
	468725	1	Shoulder Length Hood				
	465008	1	Bag, Drawstring				
	10075903	1	Head Harness, Cloth				
	10075901	1	Head Harness, Rubber				

FLOW CONTROL DEVICES

ADJUSTABLE VALVE-CONNECTORS WITH COMPONENTS

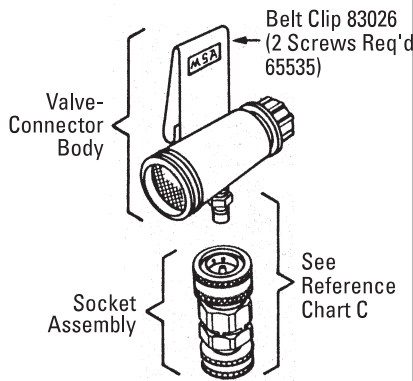

Quick-Disconnect	Complete Assembly Valve-Connector Body with Socket Assembly	Valve-Connector Body Less Socket Assembly
Components	35-40 psig	35-40 psig
Snap-Tite Aluminum	460814	474022
Snap-Tite Brass	471812	474023
Snap-Tite Stainless Steel	471813	474024
Foster Steel	471814	474025
Hansen Brass	471815	474026
Foster Brass	473828	474027

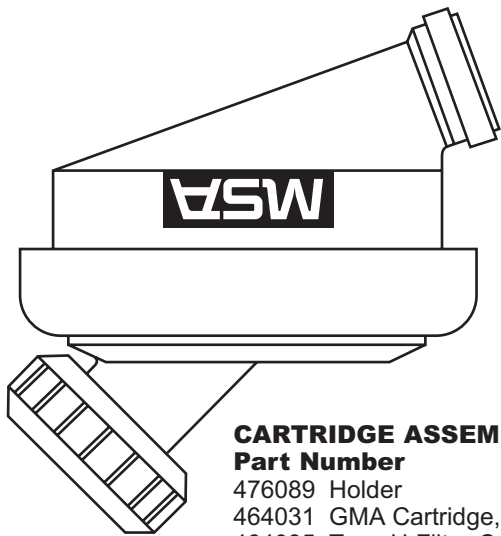

CARTRIDGE ASSEMBLY

Part Number

476089 Holder

464031 GMA Cartridge, Package of 10

464035 Type H Filter Cartridge, Package of 10

FLOW CONTROL DEVICES

Combination Duo-Flo

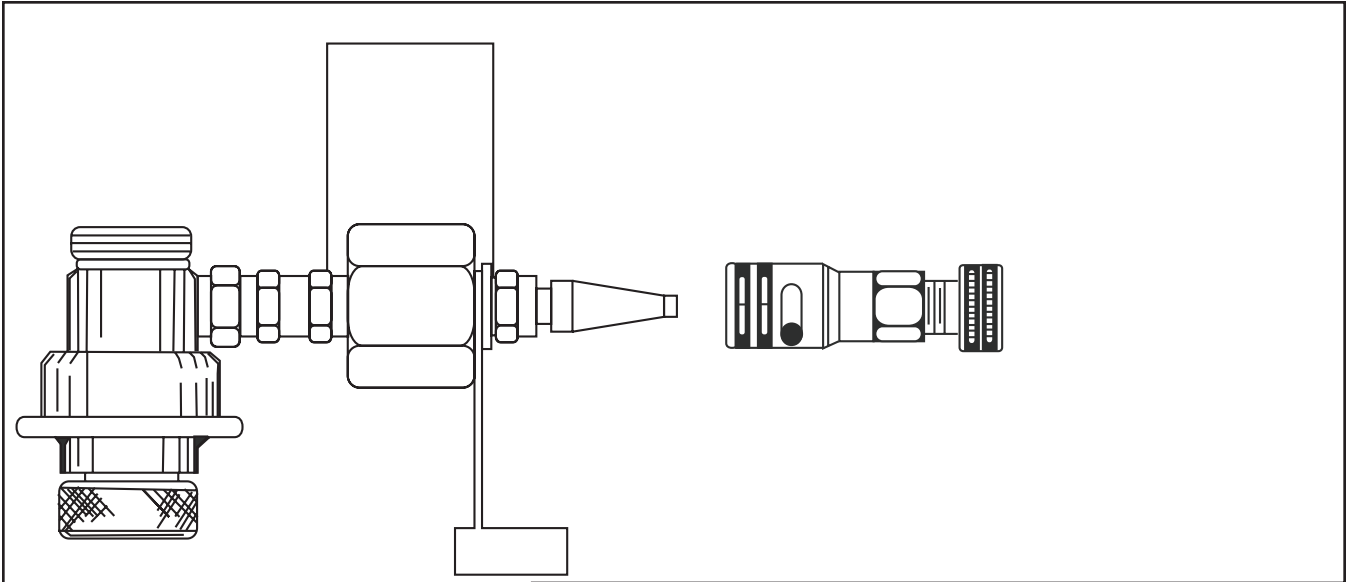

Quick Disconnect Components	Complete Duo-Flo Valve Assembly with Plug and Socket Assy. (35-90 PSIG)
Snap-Tite Aluminum	466077
Snap-Tite Brass	476919
Snap-Tite Stainless Steel	476920
Foster Steel	469869
Hansen Brass	476922
Foster Brass	476918
Locking Type	
Snap-Tite Al. (Locking)	480814
Snap-Tite Br. (Locking)	480816
Snap-Tite St. St. (Locking)	480815
CEJN Chrome (Locking)	480813

AIR-SUPPLY HOSES

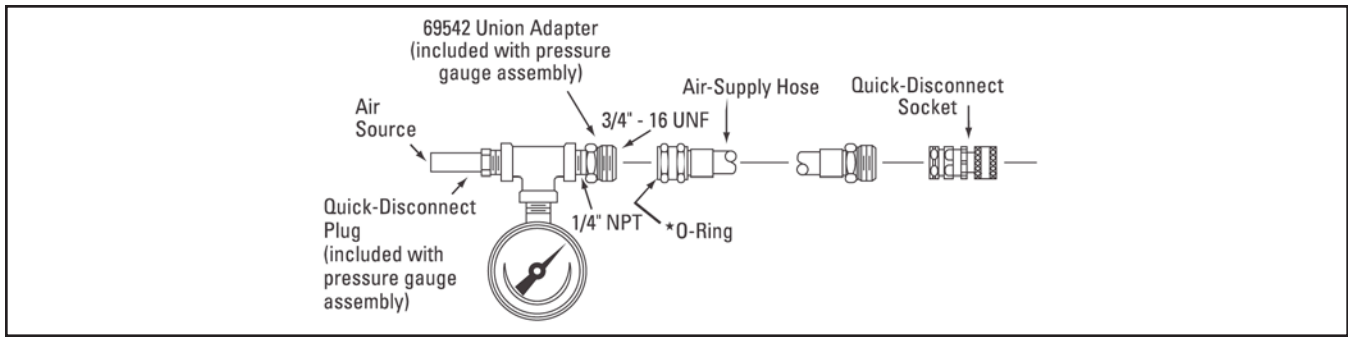

PRESSURE GAUGE ASSEMBLY

Table 5

PRESSURE-GAUGE ASSEMBLY Part No.	PLUG TYPE
476734	SNAP-TITE
476735	FOSTER
476737	HANSEN
476738	CEJN (locking type)
481377	SNAP-TITE (locking type)

AIR SOURCE

The Abrasi-Blast Respirator Hood requires a pressure regulated source of clean, respirable compressed air. The purity of the air source is the responsibility of the user. The respirator is approved only when the air supplied to the respirator meets the requirements of the Compressed Gas Association Specification G-7.1 for Quality Verification Level (Grade) D Breathable Air.

AIR-SUPPLY HOSE

The respirator can be used with a wide range of MSA air-supply hoses, which can be interconnected up to a maximum length of 300 feet. A maximum of 12 sections of air-supply hose may be used in making up the maximum working length of hose. The coiled hoses are considered to be the indicated length, although actual extended lengths can be less than indicated. (Maximum of one section of 8, 15, or 25 ft. of coiled hose or 6 sections of 50 ft. coiled hoses). MSA also offers an inlet pressure-gauge assembly that enables a user to check pressure at the inlet of the MSA air-supply hose, thus assuring that the air pressure is within the NIOSH approved range. The gauge is supplied with quick-disconnect fittings to accommodate your particular air-line system.

Part numbers for various MSA air-supply hoses that can be used are listed in Table 6.

NOTE: All air-supply hoses listed below are 3/8" in diameter (hose ID).

Table 6

PART NUMBER	HOSE LENGTH (FT.)	MATERIAL
481071	8	NEOPRENE
455020	15	NEOPRENE
455021	25	NEOPRENE
455022	50	NEOPRENE
481051	8	POLYVINYL CHLORIDE
471511	15	POLYVINYL CHLORIDE
471512	25	POLYVINYL CHLORIDE
471513	50	POLYVINYL CHLORIDE
484225	100	POLYVINYL CHLORIDE
491513	8	COILED NYLON
491514	15	COILED NYLON
491515	25	COILED NYLON
474043	50	COILED NYLON

⚠ WARNING

Particles and contaminants can enter an air-line respirator system when air-supply hoses are disconnected and/or reconnected in a contaminated atmosphere. This could result in inhalation of contaminants. It is the user's responsibility to determine the potential risk and take the necessary precautions, which may require prohibiting disconnection or reconnection of air-supply hoses in a contaminated atmosphere. If in doubt DO NOT disconnect and/or reconnect. Misuse can result in serious personal injury or death.

⚠ CAUTION

MSA air-supply hoses have various temperature limitations. Do not use when inlet air-temperature exceeds the limits specified for each hose material.

Table 7

HOSE MATERIAL	RECOMMENDED TEMP. LIMITS
Polyvinyl Chloride	32°F - 120°F
Neoprene	-25°F - 212°F
Nylon	-25°F - 120°F

INTERCONNECTING AIR-SUPPLY HOSES

INTERCONNECTING AIR-SUPPLY HOSES

MSA air-supply hoses can be interconnected up to a maximum length of 300 feet without voiding the NIOSH approval of the device. MSA offers both threaded and locking-type quick-disconnects to interconnect hoses.

The following threaded connector assembly can be used to interconnect sections of approved air-supply hose.

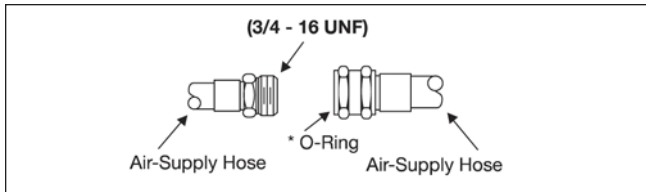

⚠ WARNING

Check all hose connections to be sure fittings are secure. This must be done to ensure a continuous flow of air. Misuse can result in serious personal injury or death.

⚠ CAUTION

Do not use non-locking quick-disconnects to interconnect air-supply hoses. Use only the threaded connector (3/4-16 UNF) or the locking-type quick-disconnects listed.

The CEJN chrome and SNAP-TITE locking quick-disconnects shown below may be used to interconnect air-supply hoses. To connect, push the plug and socket together. To separate, the plug and socket must be pushed together and the sleeve retracted from the plug.

CEJN Chrome (C)

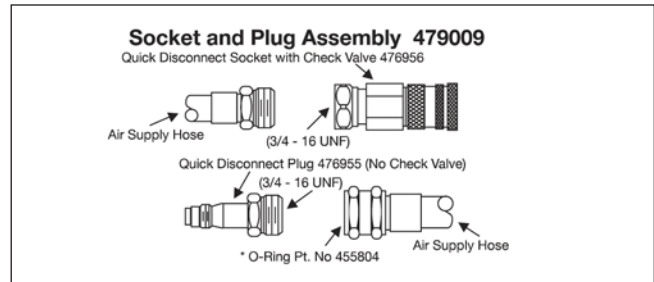

SNAP-TITE Aluminum (AL)

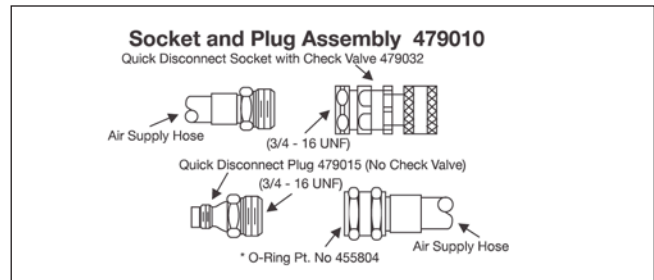

QUICK-DISCONNECTS

Various quick-disconnect assemblies that can be used with the system are shown below. Quick-disconnects are required to connect air-supply hoses to the respirator. Additionally, locking-type quick-disconnects can be used to interconnect lengths of MSA air-supply hose. Air-supply hoses can be interconnected up to a maximum length of 300 feet. Up to 12 sections of hose can be used to make up the maximum working length of hose.

Locking quick-disconnects easily connect by pushing the plug and socket together. To separate, the plug and socket must first be pushed together then the sleeve retracted from the plug.

QUICK-DISCONNECTS

LOCKING TYPES

CEJN — Chrome (C)

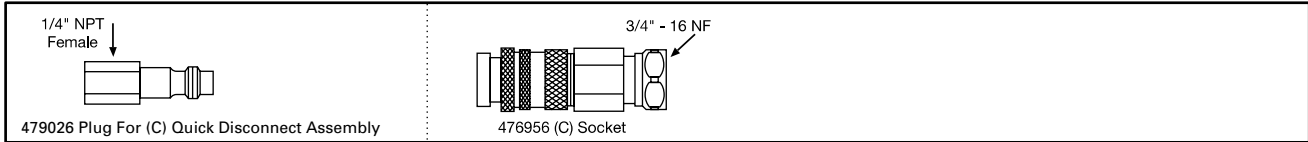

SNAP-TITE — Aluminum (AL)

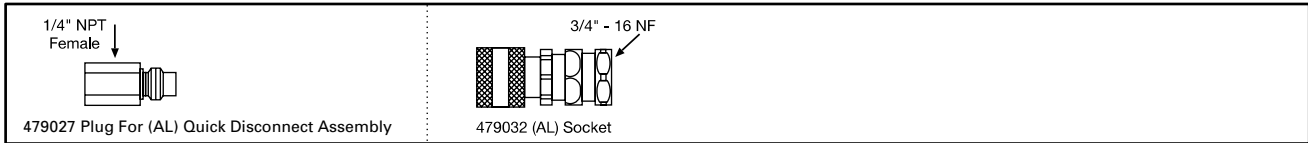

NON-LOCKING TYPES

SNAP-TITE — Aluminum (AL) Brass (BR)

Stainless Steel (SST)

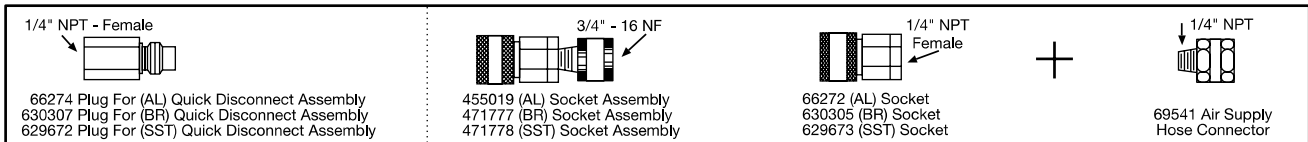

FOSTER — Steel (S) Stainless Steel (SST)

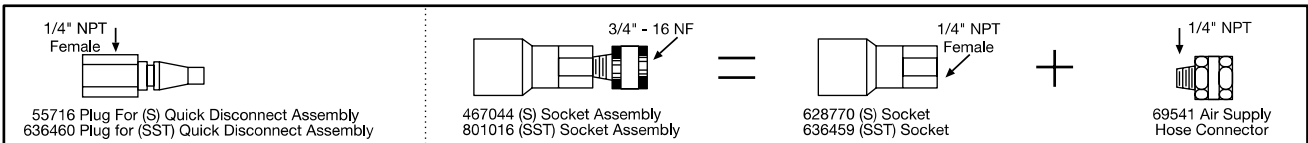

HANSEN — Brass (BR)

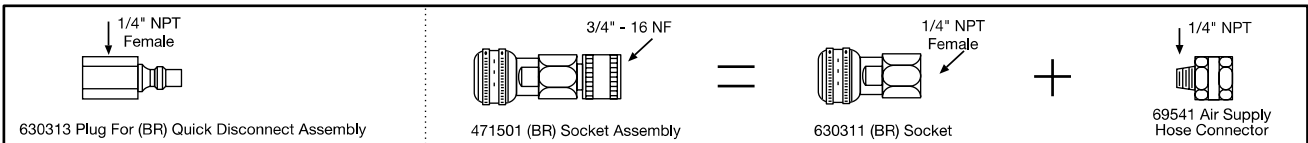

DUFF-NORTON — Brass (BR)

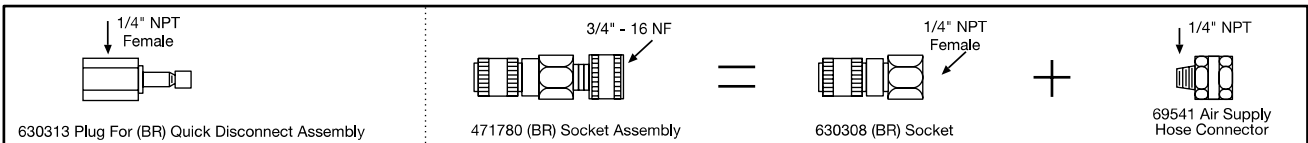

NON-LOCKING TYPES — WITH CHECK VALVE IN PLUG

FOSTER — Brass (BR)

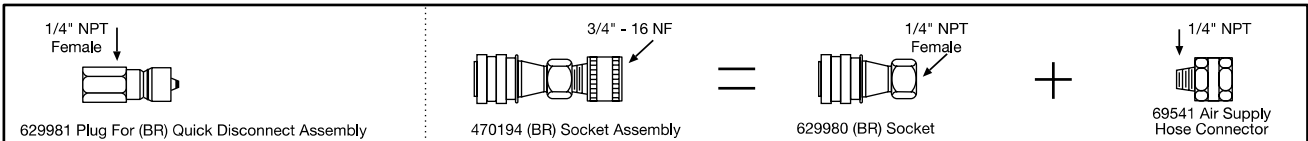

HANSEN — Stainless Steel (SST)

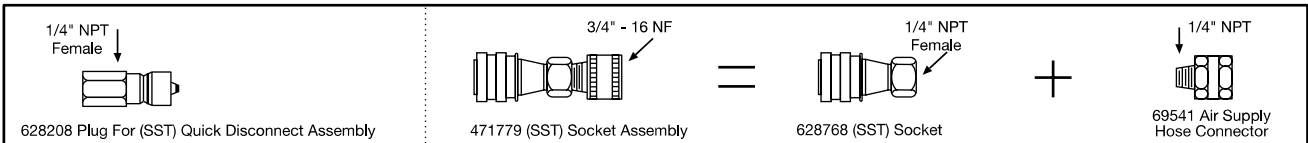

For More Information, call 1-800-MSA-2222 or Visit Our Website at www.MSAnet.com



MINE SAFETY APPLIANCES COMPANY
CRANBERRY TWP., PENNSYLVANIA, U.S.A. 16066