

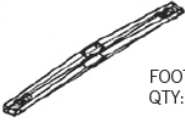







PARTS (remove all the parts from the carton and verify part quantities as indicated on this parts list.)

<p>①</p>  <p>FOOT QTY: 2</p>	<p>②</p>  <p>COLUMN QTY: 2</p>	<p>③</p>  <p>FRAME QTY: 1</p>	<p>④</p>  <p>BRACKET QTY: 2</p>	
<p>⑤</p>  <p>1" HEX SCREW QTY: 8</p>	<p>⑥</p>  <p>2 3/4" HALF-ROUND HEX SCREW QTY: 8</p>	<p>⑦</p>  <p>1/2" HALF-ROUND HEX SCREW QTY: 4</p>	<p>⑧</p>  <p>1/2" PHILLIPS HEAD SCREW QTY: 8</p>	<p>ALLEN WRENCH QTY: 1 small 1 large (Save for future tightening)</p> 

INSTRUCTIONS

STEP 1 Fasten the feet to the columns using the 2 3/4" half-round hex screws ⑥. Hook the steel brackets into the columns.

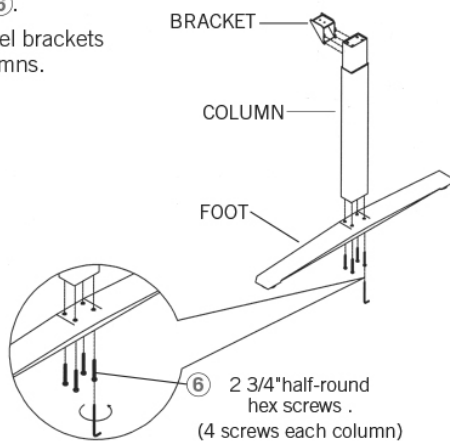

STEP 2 Fasten the legs to the frame using the 1" hex screws ⑤ and 1/2" half-round hex screws ⑦.

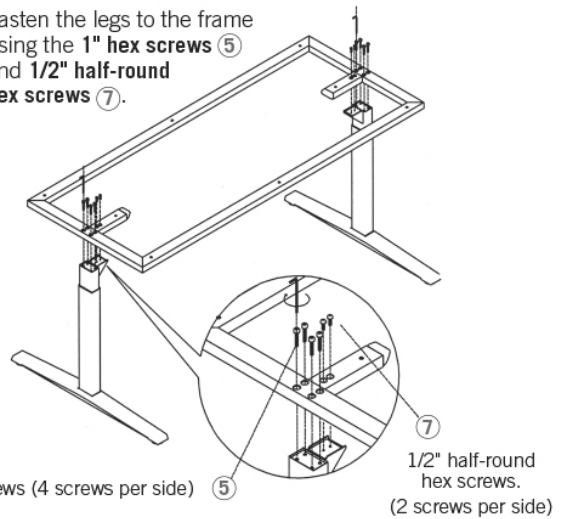

STEP 3 Align the holes of the frame to the screw holes in the top and fasten using 1/2" phillips head screws ⑧. Cover the holes with the plastic covers.

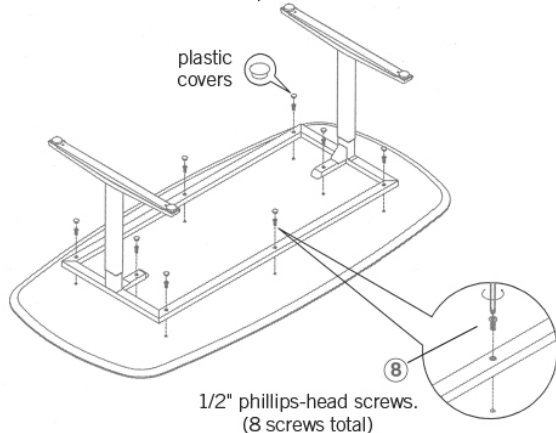

STEP 4 FINISHED! Please use 2 or more people to set the table upright and in place.

