

100% New Starter Motor Features and Benefits

1 Process Controls: ISO International Quality Standards

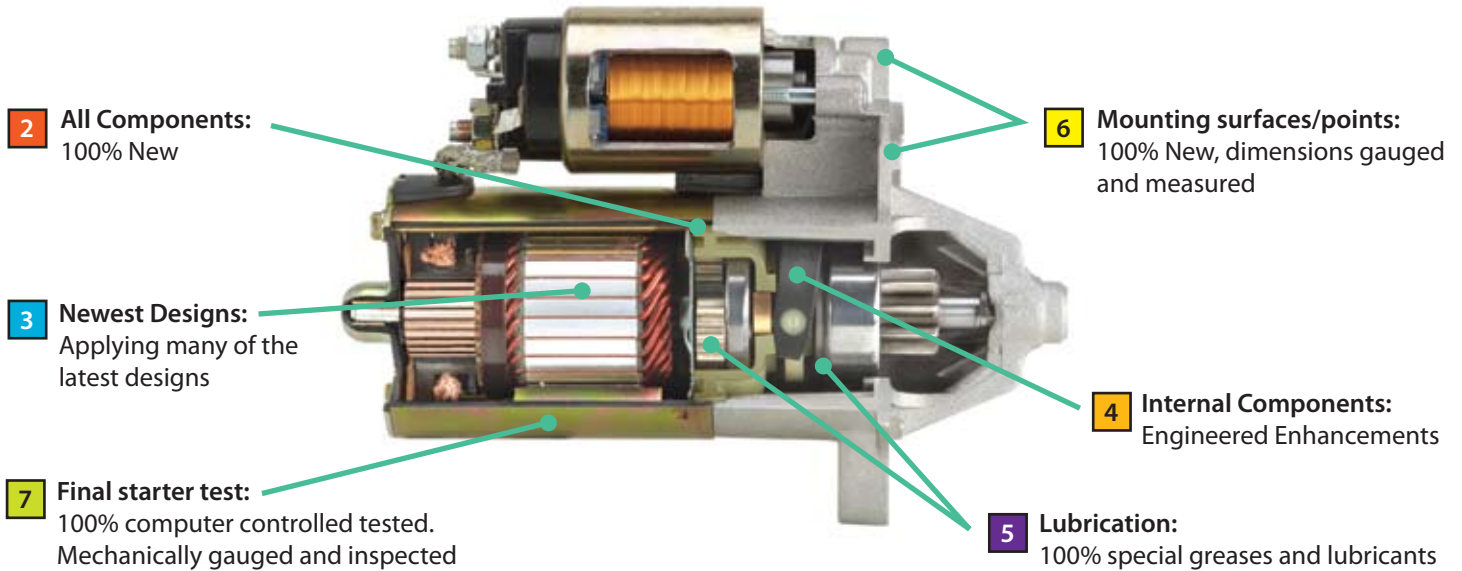

1	Process Controls Remanufactured under the guidelines of International ISO Quality Standards.	▶	Consistent Quality
2	All Components 100% New	▶	Improved performance and long life reliability
3	Newest Designs Applying many of the newest/latests designs	▶	Providing the latest most effective and efficient unit available for your vehicle
4	Internal components Many have engineered enhancements/improvements to the original / OE design and capability	▶	Improved performance and reliability providing increased ability to meet vehicle electrical demands
5	Lubrication 100% Special greases and lubricants	▶	Long term reliability in the harshest conditions
6	Mounting Surfaces/Points 100% New, dimensions gauged and measured	▶	Proper fit
7	Final Starter test 100% Computer controlled tested - mechanically gauged/inspected	▶	Verifies correct vehicle fit and function