



How to use this catalog

In looking up applications in this catalog, you will find the format unchanged from the version printed in 2006. The listings are laid out by vehicle make, vehicle model, year, engine configuration, and finally engine VIN or engine model designation. The engine VIN is used for domestic applications and the engine model designation is used for import applications. Included in the front of this catalog is a helpful engine finding index. This index will assist in selecting the correct VIN/Engine model in the applications section.

Due to the complexity of today's vehicles, the selection of a fuel pump for an application can be a complex task. The service technician can no longer assume the year of the vehicle and get the right pump. The technician must have the proper year!

The same is true for the engine for a given make. Within a given year, the 231 Engine can exhibit many designs. These may all effect the fuel system of the vehicle.

The technician must have the correct engine information!

The vehicle may also contain optional equipment that could effect pump selection. Some of these include cruise control and dashboard options. The technician must know the equipment included on the vehicle!

Last but not least, you may be required to know the capacity of the fuel tank for the vehicle being serviced. The height or depth of the hanger could be compromised if the pump is incorrectly selected.

The technician can determine the tank capacity by looking in the vehicle's repair manual or by filling it completely and then draining the tank.

As you can see, the selection of a pump for today's vehicles can be complex.

The first section of the catalog is a **technical section** containing miscellaneous specifications and service-related data describing our products.

NAPA FUEL PUMPS				NAPA FUEL PUMPS			
Years	Displ	Qualifier	Part No.	Years	Displ	Qualifier	Part No.
CHEVROLET TRUCK -1 TON VAN (Cont'd)				CHEVROLET TRUCK -1 TON VAN (Cont'd)			
P30 SERIES (Cont'd)				P30 VAN (Cont'd)			
L6				V6			
65 cont.	4.8L/292cid	Late	(Mech. Pump) M4503 (Push Rod) PR1 (Mech. Pump) M3122 (Push Rod) PR1	98	4.3L/262cid	(W)	(Module Assy.) P74758M ²⁵
		Early (Mech. Pump) M3122 (Push Rod) PR1	97 - 96	4.3L/262cid	(W)	(In-Tank Pump) P74167 ²⁵ (Strainer) STS-122
64	3.8L/230cid		(Mech. Pump) M3530 (Push Rod) PR1	95 - 90	4.3L/262cid	(Z)	(In-Tank Pump) P74000 ²⁵ (Strainer) STS-122
	4.8L/292cid	Std. Eng.	(Mech. Pump) M3122 (Push Rod) PR1	V8			
63	3.8L/230cid		(Mech. Pump) M3530 (Push Rod) PR1	99	5.7L/350cid	(R) School Bus	(Module Assy.) P74798M ²⁵
60	3.9L/235cid	w/Vacuum Wipers w/Elec. Wipers	(Mech. Pump) M73005 (Mech. Pump) M2999 (Push Rod) PR1			(R) Exc. School Bus; Federal Emissions	(Module Assy.) P74758M ²⁵
V8					6.5L/395cid	(F)	(In-Line Pump) P74222
62	4.6L/283cid		(Mech. Pump) M4712 (Push Rod) PR1			(Y)	(In-Line Pump) P74222
P30 VAN				98	5.7L/350cid	(R) w/Federal Emissions (NF4); Exc. School Bus	(Module Assy.) P74758M ²⁵
L6						(R) School Bus	(Module Assy.) P74798M ²⁵
89 - 88	4.8L/292cid	(T)	(Mech. Pump) M6738			(R) 9400, 10000, 11000, 12000 GVW; Calif. Emissions; Exc. School Bus	(Module Assy.) P74799M ²¹
87	4.8L/292cid	(T)	(Mech. Pump) M60406			(R) 14100 to 16000 GVW; Calif. Emissions; Exc. School Bus	(Module Assy.) P74758M ²⁵
86	4.8L/292cid	(T)	(Mech. Pump) M6738		6.5L/395cid	(F)	(In-Line Pump) P74143
85 - 84	4.8L/292cid	(T) w/o A/C	(Mech. Pump) M6738		7.4L/454cid	(B)	(Module Assy.) P74765M ²⁵
	4.8L/292cid	(S)	(Mech. Pump) M4503 (Push Rod) PR1	93 - 90	3.1L/190cid	(V)	(In-Tank Pump) P74000 ²⁵ (Strainer) STS-122
69 - 68	4.8L/292cid	(S)	(Mech. Pump) M4503 (Push Rod) PR1		6.2L/379cid	(J)	(Mech. Pump) M60281 (Push Rod) PR4
V6					7.4L/454cid	(N)	(In-Tank Pump) P74000 ²⁵ (Strainer) STS-122
99	4.3L/262cid	(W) High Performance	(Module Assy.) P74758M ²⁵				

²¹Features CleanScreen Technology and Wiring Harness ²²Features CleanScreen Technology ²³Includes Wiring Harness

The **application section** of this catalog follows, and contains both mechanical (M prefix) and electrical (P prefix) part numbers.

Electric pumps shown at the beginning of various application listings are universal in-line gerotor pumps used as replacement pumps for carbureted vehicles only.

Other electric pumps listed are for specific applications for either carbureted or fuel injected vehicles. Most of the electric pumps listed are O.E. replacements.

Select applications have consolidated designs that will meet or exceed the needs of the system. These parts also fit within the envelope designs of the hangers. The use of fuel injected pumps on carbureted applications can result in injury, premature product failure or damage to other components of the fuel system.

Listed in the catalog will be part numbers with a suffix H, M or S. An **H suffix** denotes an in-tank pump on a hanger. An **M suffix** denotes a module, a plastic housing including a sender. An **S suffix** denotes a sender, or a pump and hanger containing a sender.

All other electric pumps without a suffix are defined in the text as sets or pumps that are **in-tank** or **in-line applications**.

Below each listing are footnotes that advise of new technologies and/or ways to make the job easier.

Various listings of the catalog will show in-tank applications that are sold as a set. This means that the pump contains the appropriate fuel tank strainer. Listed below the set number are its pump and strainer components, which are available as separate parts. In both cases the set or pump may contain additional parts for proper installation.

The pump and strainer must be sold together; failure to replace the strainer will result in shortened product life!

You will also notice **PTS prefix** parts listed with an application. These are pump tank seals and are required to be installed when replacing a failed fuel pump.

Immediately following the automotive and truck section will be the **agricultural, industrial and marine sections**. These sections are separate, making it easier to focus on specific markets. The marine section includes clocking information and product designs.

The **universal electric pumps**, shown following the marine section, are intended for use on carbureted vehicles and as a transfer pump for some diesel applications. In-line electric fuel pumps may be used as general replacements for inoperative mechanical pumps or in-line electric pumps. Selection of these products is generally by voltage, pressure, fuel flow and physical dimensions.

Under no circumstances are they to be used as replacements for aircraft or fuel injection applications!

Illustrated next are **performance pump** applications. These parts are sold by engine application rather than by vehicle year application. These parts are universal in application and may require clocking to align fittings.

The next section illustrates different types of **wire harnesses** used on GM applications with known connector issues.

The **numerical section** immediately follows and lists all parts that are available, a picture of the part, and a brief description of the application covered by the part. The last section of the catalog contains interchanges. After crossing a number, always recheck the specific application information for verification. Listings in both of these sections are intended only as a guide.

FUEL PUMPS





Warranty

NAPA Fuel Pumps Warranty Statement

- NAPA fuel pumps are warranted to be free from defects in material and workmanship, under normal use and service, for 12 months or 12,000 miles from the date of purchase. The remedy for breach of this warranty is limited to free exchange of the product shown to our satisfaction to be defective. Liability for neglect, misuse, special, incidental, direct, indirect, and consequential damages is specifically disclaimed. No other warranty, either expressed or implied, including any warranty of merchantability of fitness for a particular purpose is made.
- The allegedly defective part should be returned in the NAPA box for the FREE exchange and accompanied with:
 - Strainer
 - Completed in full, NAPA-supplied warranty tag
 - Copy of original invoice or work order for the allegedly defective pump – not the replacement pump
- Credit will not be issued without these. The information supplied on the tag is important to assure that proper credit is issued. All tags and invoices are sent in for review to validate the credit, and to assure that NAPA Fuel Pumps will continue to distribute the highest quality fuel pump in the industry.

Professionals, don't risk invalidating the warranty!

Be sure to check for the following:

- 13.5 Volts at the pump
- Clean tank
- New strainer
- New in-line filter

Marine Fuel Pumps

Designed to resist corrosion and to operate efficiently, NAPA fuel pumps for marine applications provide consistent, worry-free performance.

Marine Universal Electric Fuel Pumps

Almost all inboard and stern-drive boats produced today are fuel-injected and use electric fuel pumps. Older marine applications utilize mechanical fuel pumps to provide fuel to the carburetor. The rotary vane and solenoid pumps shown below are ideal universal electric pump replacements for mechanical pumps that are no longer available or are hard to find. Steel and, preferably, stainless steel lines are to be used from the fuel tank to the electric pump, as well as from the fuel pump to the carburetor. The mechanical pump should be removed and a block-off plate installed on the pump-mounting hole on the block.

P4070, P4259, P4389, P4594, P4600HP, P4601HP, P4603HD

Rotary Vane Design

- Positive displacement
- Compact, rugged

See universal electric fuel pumps pages for specifications.

All rotary vane type fuel pumps meet United States Coast Guard regulations 183.524 and 183.590

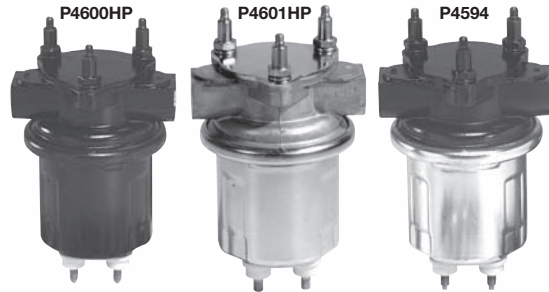

Recommended for use on 4, 6 and 8 cylinder engines

Voltage	Flow (GPH)	PSI	Inlet/Outlet	Part No.
12	72	4-8	1/4" NPSF for 3/8" Hose	P4070
6	72	4-8	1/4" NPSF for 3/8" Hose	P4259
12	72	4-8	1/4" NPSF for 3/8" Hose	P4389
12	72	5-9	1/4" NPSF for 3/8" Hose	P4594
12	100	6-8	3/8" NPSF for 1/2" Hose	P4600HP
12	100	12-16	3/8" NPSF for 1/2" Hose	P4601HP*
24	43	5-9	1/4" NPSF for 3/8" Hose	P4603HD

18-14U Quiet Pack available for more quiet operation.
*Requires Pressure Regulator 404-500HP or equivalent.

888-531 Kit Bag for Wiring



P74016, P74018, P74021, P74022

Solenoid Design

- Compact
- 12 or 24 volt models
- Positive displacement



Recommended for use on 4, 6 and small displacement 8 cylinder engines

Voltage	Flow (GPH)	Pressure (PSI)	Specification	Part No.
24	20-30	5.5 - 9.0	1/4" - 18 NPSF & 3/8" Hose Fitting	P74016
24	20-30	10.0 - 14.0	1/4" - 18 NPSF & 3/8" Hose Fitting	P74018
12	20-30	3.5 - 5.5	1/8" - 27 NPSF & 5/16" Hose Fitting	P74021
12	20-30	5.5 - 9.0	1/8" - 27 NPSF & 5/16" Hose Fitting	P74022

All electric pumps, either in-line or in-tank, emit noise due to the function of the electric motor contained within. Make sure the pump you are installing utilizes a grommet or insulating sleeve that is provided or is reused from the pump being replaced. Contact with metal parts, and to a lesser degree plastic, will transmit pump noise through the hanger and the tank, resulting in amplified noise inside the craft.

WARNING: Limited life expectancy with methanol. Usage of methanol voids warranty.
WARNING: THESE PUMPS ARE NOT INTENDED FOR AIRCRAFT USAGE. DO NOT USE PTFE TAPE ON ANY FITTING.
WARNING: For safety reasons, it is recommended that an A-68301 Pressure Safety Switch be installed. This will prevent engine damage and reduce the chance of fire in the case that the engine stops without the ignition switch in the "off" position.
 Unless otherwise indicated, parts in this catalog are not intended for use in emission controlled vehicles that must comply with federal, state and/or local emission regulations.



Marine Mechanical Fuel Pumps

At times the model or displacement of an engine may be difficult to determine. If the pump is available it can be identified by checking the clocking of the pump. Simply hold the pump with the lever facing away from you at the 12 o'clock position.

Then note the clock positions of the inlet and outlet (the diagram below illustrates this, showing a view of the bottom of the pump).

Once you have defined these you can locate the proper pump by the chart shown. In the catalog, the numbers shown in parentheses with an application denote the clocking of a pump. For example, (3.6.9) illustrates a pump with a 3 o'clock inlet, 6 o'clock outlet, and 9 o'clock separator. You must also check the levers to see that they are correct for the application. You may also check the cross-reference chart if the pump has an identifiable number on it. If you are unable to identify the model of the boat/engine/year, the matrix below will show you the inlet/outlet/separator of our pumps. If you have a match you can then compare the two pumps and review the application data.

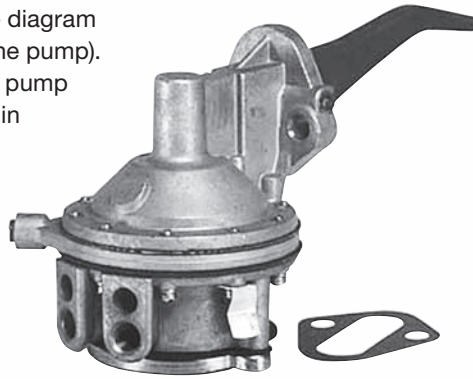

Part No.	Inlet	Outlet	Separator
M3497	4	7	NR
M60176	9	3	NR
M73021	10	9	7
M73039	7	5	4
M73044	9	3	10
M73046	5	4	4

NR = Not Required

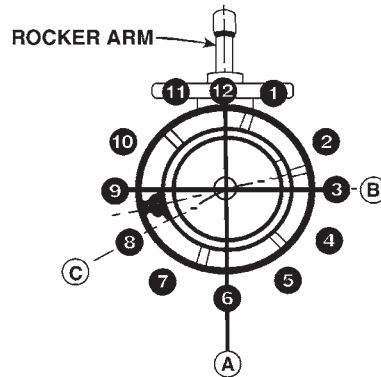

Marine Pump Vent Tube Kit - Part No. 888-74

This kit is designed to be used with marine mechanical fuel pumps that have a hose nipple pressed into the atmospheric vent. This allows for the upgrade of older marine systems to the current safety level if no carburetor or flame arrestor tube exists. This also gives a visual check of the fuel pump diaphragm through the use of a clear sight tube. This tube should be observed during the pre-start checkout every day that the boat is used. If fuel is observed in this tube, the fuel pump should be replaced immediately. Failure to do so will result in excess fuel usage and ultimately in pump failure, which could strand the boater in open water. Included in the kit are a flame arrestor grommet, three feet of tubing, a flame arrestor elbow tube and one tube clamp.

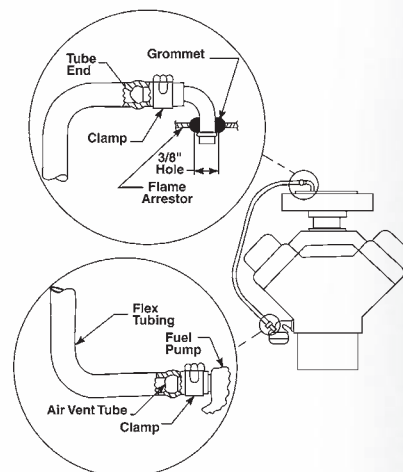

Universal In-Line Electric Fuel Pumps

Gerotor Style

The gerotor is unquestionably the most versatile pump design today. Compact, lightweight and fuel-cooled, NAPA Fuel Pumps Carotor® universal pumps are available for applications ranging from carbureted to TBI & MFI systems. They utilize a unique gear and rotor eccentric mechanism that squeezes the fuel within the pump to create high pressure with very little pulsation.

Performance Characteristics of Carotor Universal In-Line Electric Fuel Pumps for Carbureted Vehicles:

- Operates using leaded and unleaded gasoline, gasohol, diesel fuels and fuel boosters
- Simple installation on vehicle (any altitude)
- Complete mounting package included
- Quiet operation
- Lightweight – only 12-1/2 ounces
- Gas filter (included) or equivalent must be used
- Will operate at six volts with resultant decrease in flow
- Tolerant of overvoltage conditions
- Corrosion resistant
- Positive displacement gerotor-type gear pump – self-priming
- DC permanent magnet wet motor
- Internal pressure regulator valve
- Glass-reinforced thermoplastic inlet and outlet



Voltage	Flow (GPH)	Pressure (PSI)	Application	Part No.
12	30	4-6	Domestic Passenger Car, Light Truck, Fleet & Industrial	P60430
12	30	2-4	Imported Passenger Car & Light Truck	P60504

WARNING: Limited life expectancy with methanol. Usage of methanol voids warranty.
WARNING: THESE PUMPS ARE NOT INTENDED FOR AIRCRAFT USAGE. DO NOT USE PTFE TAPE ON ANY FITTING.
WARNING: For safety reasons, it is recommended that an A-68301 Pressure Safety Switch be installed. This will prevent engine damage and reduce the chance of fire in the case that the engine stops without the ignition switch in the "off" position.
 Unless otherwise indicated, parts in this catalog are not intended for use in emission controlled vehicles that must comply with federal, state and/or local emission regulations.

Universal In-Line Electric Fuel Pumps

FUEL PUMPS



Rotary Vane Style

Originally created for military use, this design has been in production longer than any other NAPA fuel pump model. It is appropriate for RV, marine, agricultural, industrial and performance applications.

Performance Characteristics of Rotary Vane Universal In-Line Electric Fuel Pumps for Carbureted or Diesel Vehicles:

- Operates using leaded and unleaded gasoline, gasohol, diesel fuels and fuel boosters
- Easy to install, with complete installation package and instructions
- Free-flow fuel delivery
- Positive displacement pump – motor-driven rotary vane type
- Constant fuel flow
- Positive (+) or negative (-) ground
- Internal pressure regulating valve
- No points to burn out
- No shaft seals subject to deterioration and leakage
- 72 or 100 gph flow
- Distinctive black/silver finish on P4600HP
- Black dichromate/"E" coat finish on P4601HP
- Filter required
- Flow check valve on P4602RV

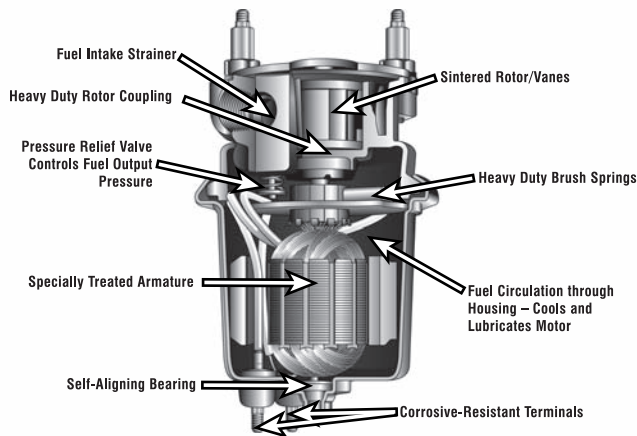

All rotary vane type fuel pumps meet United States Coast Guard regulations 183.524 and 183.590



Recommended for use on 4, 6 and 8 cylinder engines

Voltage	Flow (GPH)	Pressure (PSI)	Inlet/Outlet Specification	Application	Part No.
12	72	4-8	1/4" NPSF for 3/8" Hose	Passenger, Fleet, RV Industrial	P4070
6	72	4-8	1/4" NPSF for 3/8" Hose	Passenger, Fleet, RV Industrial	P4259
12	72	4-8	1/4" NPSF for 3/8" Hose	Marine	P4389
12	72	5-9	1/4" NPSF for 3/8" Hose	High Performance	P4594
12	100	6-8	3/8" NPSF for 1/2" Hose	High Performance	P4600HP
12	100	12-16	3/8" NPSF for 1/2" Hose	High Performance	P4601HP*
12	72	5-9	1/4" NPSF for 3/8" Hose	Recreational Vehicle	P4602RV
24	43	5-9	1/4" NPSF for 3/8" Hose	Heavy Duty, Marine	P4603HD

18-14U Quiet Pack available for more quiet operation.
*Requires Pressure Regulator 404-500HP or equivalent.

888-531
Kit Bag
for Wiring



Universal In-Line Electric Fuel Pumps

Solenoid Style

Rather than a motor, the solenoid pump uses a piston actuated by an electromagnetic coil to generate fuel pressure and flow. By using only short pulses of electricity, the solenoid pump is very energy-efficient. It is also long-lasting, with no internal rubber parts or bellows to wear out.

- The solenoid pumps featured here are for carbureted and diesel applications only. All of the pumps listed may be used as boost pumps. Each pump contains specific mounting hardware and instructions. The solid state solenoid type pumps shown on this page contain no internal rubber parts or bellows to wear out. Each application is self-priming, completely sealed against leakage and protected against reverse polarity. A filter is required on the inlet side of the pump. Failure to use a filter will void the warranty.



P74016

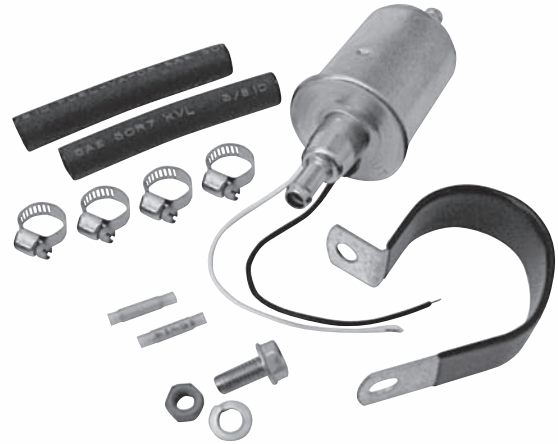

P74017

Recommended for use on 4, 6 and small displacement 8 cylinder engines

Voltage	Flow (GPH)	Pressure (PSI)	Inlet/Outlet Specification	Application	Part No.
24	20-30	5.5 - 9.0	1/4" - 18 NPSF & 3/8" Hose Fitting	Heavy-Duty & Industrial	P74016
12	20-30	10.0 - 14.0	3/8" Hose Fitting	Passenger Car & Light Truck	P74017
24	20-30	10.0 - 14.0	1/4" - 18 NPSF & 3/8" Hose Fitting	Heavy-Duty & Industrial	P74018
12	20-30	5.5 - 9.0	3/8" Hose Fitting	Passenger Car & Light Truck	P74019
12	20-30	10.0 - 14.0	1/8" - 27 NPSF & 5/16" Hose Fitting	Passenger Car & Light Truck	P74020
12	20-30	3.5 - 5.5	1/8" - 27 NPSF & 5/16" Hose Fitting	Passenger Car & Light Truck	P74021

WARNING: Limited life expectancy with methanol. Usage of methanol voids warranty.
WARNING: THESE PUMPS ARE NOT INTENDED FOR AIRCRAFT USAGE. DO NOT USE PTFE TAPE ON ANY FITTING.
WARNING: For safety reasons, it is recommended that an A-68301 Pressure Safety Switch be installed. This will prevent engine damage and reduce the chance of fire in the case that the engine stops without the ignition switch in the "off" position.
 Unless otherwise indicated, parts in this catalog are not intended for use in emission controlled vehicles that must comply with federal, state and/or local emission regulations.



Universal Pump Locations

The universal fuel pump should be mounted below the fuel tank, as all pumps do not have equal lift capabilities. Also, the pump must be mounted below the carburetor to avoid possible vapor lock conditions occurring. Under no circumstances should the pump be mounted in the trunk, inside the vehicle, or in the engine compartment; personal injury could occur in the event of a fuel line rupture.

Always mount a good quality fuel filter on the inlet side of the pump. Failure to do so will void the warranty.

Do not mount the pump near exhaust system components, as heat contributes to vapor lock.

Care should be exercised to protect the pump from splash or water immersion.

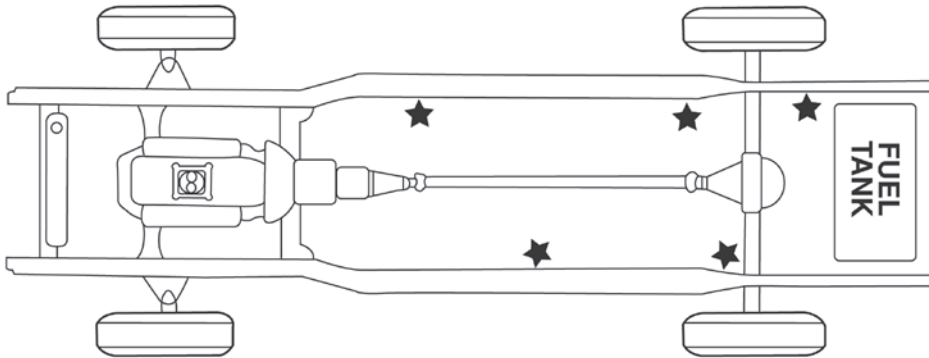

NOTE: NOT ALL UNIVERSAL ELECTRIC FUEL PUMPS ARE CAPABLE OF A PULL-THROUGH ARRANGEMENT WITH AN EXISTING MECHANICAL FUEL PUMP SYSTEM. CHECK INFORMATION ON ALL UNIVERSAL ELECTRIC PUMPS.

Safety Interlock System

PRESSURE SAFETY SWITCH A-68301 INSTALLATION INSTRUCTIONS

A pressure switch should always be used in conjunction with the Universal In-Line Electric Fuel Pump. ICC Motor Carrier Safety Regulations stipulate that the fuel pump must not continue to operate after the engine stops. The Safety Interlock Circuit stops the electric fuel pump when the engine stops even though the ignition switch is not turned "Off." The pressure switch is a single-pole, double-throw, diaphragm-actuated switch. Terminals P (Pump) and S (Start) are normally closed; terminals P (Pump) and I (Ignition) are normally open. This allows the fuel pump to operate and fill the carburetor while the engine is cranking. When oil pressure exists (2 to 4-1/2 psi), the P and S terminals are opened, and the P and I are closed. The diaphragm is treated to withstand pressure up to 150 psi.

If the oil pressure drops below 2 psi, the connection between P and I opens and the fuel pump stops. This also protects the engine from severe damage if an oil line is broken or the oil level in the crankcase becomes extremely low.

Full battery voltage must be available to the pump when the ignition switch is in the start or run position. Do not connect to the ignition coil, as a ballast resistor may be built into the wire. The pressure switch should be installed at a convenient location in the engine oil pressure system. In some instances, it may be necessary to install a "T" fitting below the existing oil gauge sender or dashlight unit. Wires should be 18-gauge insulated, or heavier, routed so as to protect them from exhaust heat, and anchored securely at frequent intervals to prevent chafing.

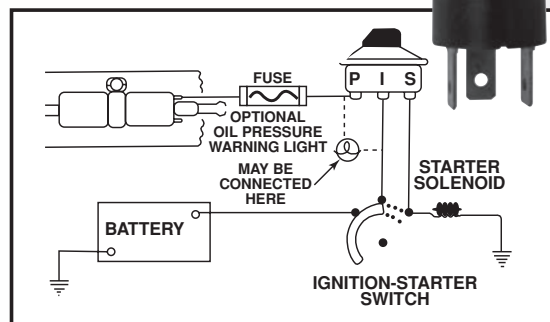

These pumps are synonymous with championship-caliber fuel delivery – remember the legendary Carter AFB carburetor? Well, since then we have added an unparalleled array of HI-Performance™ fuel pumps for the most demanding street and strip applications. These durable electric and mechanical pumps offer the kind of massive GPH capacity that fuels legends. Their innovative engineering consistently delivers fuel at the exact pressure and rate your vehicle demands. And their quality makes sure that winning performance holds up in the heat of battle and keeps flowing steadily for years to come.

Competition Series Mechanical Pumps

NAPA die-cast Competition Series Pumps feature lightweight aluminum bodies and fuel bowls combined with heat-treated high-speed levers, anti-float springs, flat diaphragms and clocking features. Great for muscle cars and classics!

Part No.	Make	Engine Displacement	PSI	GPH†
M4862	Chrysler	361, 383, 400, 413, 426, 440	8.0 - 9.5	120
M4889	Chevrolet	396, 402, 427, 454	7.0 - 8.5	120
M4891	Chevrolet	267, 283, 302, 305, 307, 327, 348, 350, 400, 409	7.0 - 8.5	120
M6270**	Chrysler	273, 318, 340, 360	6.9 - 8.1	120
M6905	Ford (FE)	352, 390, 406, 427, 428	5.5 - 6.5	120
M6906	AMC	290, 304, 343, 360, 390, 401	5.5 - 6.5	120
M6907	Pontiac	265, 301, 326, 350, 389, 400, 403, 421, 428, 455	5.5 - 6.5	120
M60454	Ford	221, 260, 289, 302, 351W	7.0 - 8.0	120
M60882	Ford	429, 460	7.0 - 8.5	120

**Fits to 1989 with Silent Timing Chain. Will not fit double row roller timing chain.
† Free flow gallons per hour

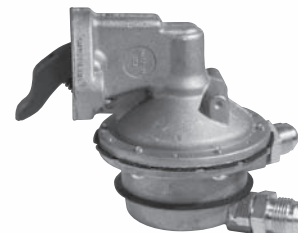

Die-Cast Billet

Billet aluminum pumps are machined from 6061-T6 aluminum on CNC machines, assuring exact dimensions on every one. They utilize a 3-valve design providing simplified operation and high flow characteristics. The reinforced diaphragms are actuated by heat-treated, channeled levers. The fuel inlet and outlet feature No.8 and No.10 AN fittings that incorporate a coppercrush washer and are sealed with Loctite®. The fittings are plated steel and match up perfectly with today's braided stainless steel fuel lines. Each pump is burnished for a highly polished finish accented with black oxide TORX® self-tapping screws.

Part No.	Make	Engine Displacement
M7900G	Chevrolet	267, 283, 302, 305, 307, 327, 348, 350, 400, 409
M7901G	Chevrolet	396, 402, 427, 454
M7904G	Ford	221, 260, 289, 302, 351W



Rotary Vane Electric Fuel Pumps

- Operate using leaded and unleaded gasoline, gasohol, diesel fuels and fuel boosters
- Easy to install with complete installation package and instructions
- Constant free-flow fuel delivery
- Positive displacement pump – motor-driven rotary vane type
- Positive (+) or negative (-) ground
- Internal pressure regulating valve
- No points to burn out
- No shaft seals subject to deterioration and leakage
- Filter required



Recommended for use on 4, 6 & 8 cylinder engines

Part No.	Voltage	Flow (GPH)	Pressure (PSI)	Inlet/Outlet
P4600HP	12	100	MAX 8	3/8" NPSF for 1/2" Hose
P4601HP*	12	100	MAX 18	3/8" NPSF for 1/2" Hose
P4602RV	12	72	MAX 8	1/4" NPSF for 3/8" Hose
18-14U Quiet Pack available for more quiet operation				

*Requires Pressure Regulator 404-501HP or equivalent.

Direct-Fit Electric Fuel Pumps

Direct-Fit HI-Performance™ electric pumps deliver ultra-precise flow and pressure to fuel-hungry performance engines. These advanced pumps are engineered and built to provide the ultimate in fuel delivery and reliability under the toughest conditions, for both domestic and import applications.

Part No.	High Performance Applications
P74105HP	Ford Mustang 5.0L, 87-92 (30% greater flow than OE)
P74151HP	Ford Mustang (High Pressure) (exc. 96-97 Cobra) 85-97
P74152HP	Nissan Sentra SE 98-99; Nissan 200SX SE-R (U.S. 200SX Only) 95-98
P74161HP	Mitsubishi Talon (FWD and AWD) 90-94; Mitsubishi Eclipse (FWD and AWD) 90-94; Mitsubishi Laser (FWD and AWD) 90-94
P74168HP	Ford Mustang 4.6L SOHC, DOHC 97-98 (30% greater flow than OE)
P74180HP	Mazda Miata 1.8 94-97
P74181HP	Mitsubishi Talon (FWD Turbo Only) 90-94; Mitsubishi Eclipse (FWD Turbo Only) 90-94; Mitsubishi Laser (FWD Turbo Only) 90-94
P74182HP	Toyota Supra 94-98
P74209HP	Buick Grand National 3.8L, 84-87; Chevrolet Camaro 5.0L, 5.7L, 85-92; Pontiac Firebird 5.0L, 5.7L, 85-92 (30% greater flow than OE)
P74215HP	Ford Mustang (Cobra) 96-97
P74217HP	Ford Lightning (Two parallel pumps) 99-00
P74223HP	Honda Civic 92-00; Acura Integra 94-99

All pumps flow 255 lph and come with everything you need to install the pump in your application.



P74209HP



Premium HP In-Line Pumps

NAPA's new line of Premium HP in-line pumps brings technology, performance and reliability together. From mild to wild, these NAPA pumps provide the optimum flow and pressure for engines up to 1100 HP. Carbureted and fuel-injected engines can benefit from the innovative designs and materials found in NAPA Premium HP in-line pumps.



P4701HP



The NAPA P4701HP is the perfect fuel pump for carbureted engines making 200-600 HP. Its high-tech design and materials provide greater flow and pressure than traditional performance pumps, and it does not require the use of a separate fuel pressure regulator.



P4700HP

NAPA P4700HP is the ultimate in-line fuel pump. Developed specifically for Supercharged and Turbo motors, this versatile EFI pump – with its full range of pump pressure – can power both street machine and Pro Street engines. The P4700HP features a dual chamber pump design and is crafted from aircraft-grade composite materials. It looks as good as it performs.

When building a street rod using a fuel-injected engine platform, it is necessary to provide components to move the fuel from an OE tank or fuel cell to the injector rail. P5000 and P5001 are in-line pumps that are designed to accomplish that. Either pump will function with the OE fuel pressure regulator, and both contain an electrical harness and other applicable installation parts.



P5000

Part No.	Fuel Delivery	PSI	Flow	Fittings	Horsepower
P4700HP	EFI	8-90	600 lbs/hr @ 45 psi	10 AN	1100 HP NA, 800 HP Forced Induction
P4701HP	Carb	18-20	140 lbs/hr @ 13.5 volts	3/8" NPT	200-700 HP
P5000	MFI	22-27	45 GPH @ 45 psi	5/8" – 18UNF	–
P5001	TBI	9-22	50 GPH @ 20 psi	5/8" – 18UNF inlet, 3/8" – 24NPT outlet	–

HI-Performance™ Regulators

NAPA HI-Performance™ regulators provide consistently outstanding performance and deliver more flow than similar regulators, thanks to a custom convoluted diaphragm that maximizes piston stroke while minimizing stress. The standard vacuum boost port delivers perfect 1:1 boost reference and makes these regulators ideal for turbocharged and supercharged engines. Available in both 3/8" NPT and 6 AN fittings.

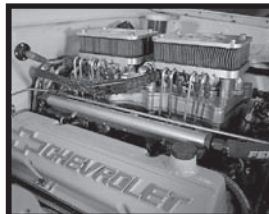

Part No.	Description	Application	PSI	Fittings
404-500HP	Fuel Regulator	Carbureted applications	5-12 adjustable	3/8" NPT ports
404-501HP	Fuel Regulator	Carbureted applications	4.5-9 adjustable	3/8" NPT ports
404-502HP	Fuel Regulator	EFI applications	30-70 adjustable	6 AN ports

HI-Performance™ Filters

Protect your pump with state-of-the-art filters. Manufactured from anodized billet aluminum, these in-line filters protect your fuel delivery system from debris. Available in several configurations:

- 3/8" NPT and 10 AN fittings
- High Flow 10 micron (fine) cleanable/replaceable stainless steel element
- High Flow 100 micron (coarse) cleanable/replaceable stainless steel element
- High Flow 10 micron (fine) replaceable fabric element



F902

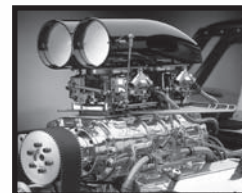

Filters

Part No.	Description	Application	Flow Rate	Fittings
F900	100 micron filter and housing	Carbureted applications	1,500 lbs/hr	3/8" NPT
F901	10 micron filter and housing	Carbureted applications	1,500 lbs/hr	3/8" NPT
F902	100 micron filter and housing	EFI applications	2,000 lbs/hr	3/8" NPT
F903	10 micron filter and housing	EFI applications	2,000 lbs/hr	3/8" NPT

Elements

Part No.	Description	Housing
FE900	100 micron stainless steel replacement filter element	F900 Housing
FE901	10 micron stainless steel filter element	F901 Housing
FE902	100 micron stainless steel filter element	F902 Housing
FE903	10 micron fabric filter element	F903 Housing

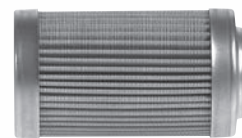

FE902

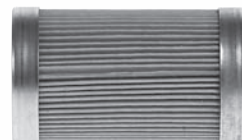

FE903

GM Trucks

You will find that GM Trucks are a common source of aftermarket fuel repair jobs. Predominantly, model years from the mid-1990s to current models have known repair problems with the following components:

- The OE roller vane-style pump is under-designed for the high pressure of the CPI fuel system, and its high electrical draw can melt the weak connectors.
- The OE pump design is ill-suited to the vibration and shock that the trucks encounter while in service.

FIND OUT WHY the failure occurred before buying parts:

Is there less than 13.5 volts at the pump?

- The repair requires a new wiring harness.
- Note that NAPA Fuel Pumps includes wiring harnesses in the box for applications with known wiring issues.

Is the gas tank rusting inside or rusted through?

- The repair requires a new tank.

Is the strainer black with grime? Or discolored, appearing packed with contaminants?

- The repair requires you to wash out the contamination and dry the tank.
- NAPA Fuel Pumps offers a robust turbine pump that is one of the best on the market, but all professionals know that installing a pump without cleaning the tank will lead to a comeback within a few months!

Special notice on GM Wiring Harnesses #1

Fuel Pump Wiring Harness – mid-to-late 90s GM trucks with hanger assemblies

Problem:

On certain GM in-tank electric pump hanger assemblies, a faulty electrical connector can cause severe voltage drop (or total loss of voltage) to the pump, a failure mode that often leads to improper diagnosis. Always remove and inspect the hanger wire harness when servicing these pumps! First inspect the electrical connector at the pump and underside of hanger. A “sooty” carbon deposit on the plastic connector, or melted wire insulation, could be a sign that the real problem is not the pump, but the wire harness. Replacing the pump without correcting the wiring will simply lead to another premature failure.

Solution:

NAPA Fuel Pumps offers “Fuel Pump Solutions” replacement wire harnesses for a full range of GM in-tank hanger assembly applications. NAPA fuel pump wire harnesses include wire insulated with “ETFE” grade covering which is resistant to corrosive fuel blends. The wire terminals are beryllium copper, resulting in improved conductivity and corrosion resistance. Plus, the cover connector and pump connector are manufactured of glass-filled nylon, providing superior rigidity, dimensional integrity and longer product life.



(con't on next page)

FUEL PUMPS



Special Feature

GM Trucks (con't from previous page)

Special notice on GM Wiring Harnesses #2

Vehicle to Fuel Pump Module Wiring Harness – late 90s to current GM trucks with fuel pump modules

Problem:

Certain GM fuel pump applications are prone to electrical connector failures. Usually, the electrical connector on the vehicle wiring harness that plugs into the fuel pump module is at fault. The positive or negative terminal within this connector begins losing continuity, creating a substantial voltage drop. The heat generated from the arcing and voltage drop melts the plastic around the positive or negative terminal. Where the terminal protrudes from this plastic connector, the plastic should have a pyramid shape. The heat generated by a failed terminal will cause the plastic around it to melt into a spherical shape. In other instances a blackening of the plastic around the terminal will be evident. The location of this faulty connection makes it impossible to diagnose the problem using a voltage drop test. So it's important to carefully inspect the connector on the old module and the connector on the vehicle body harness for evidence of this failure.

Solution:

If a failure is suspected, the section of the vehicle wiring harness with the faulty connector must be replaced.

If your vehicle requires:

- White 4-pin, four-cavity connector, use 888-553
- Black 4-pin, four-cavity connector, use 888-543
- 4-pin or 5-pin, six-cavity connector, use 888-544
- New, upgraded module connector, use 888-601

NAPA Fuel Pumps Wire Harnesses for GM module assemblies include:

- Wire insulated with "ETFE" grade covering
- Tin-plated brass wire terminals
- Glass-filled nylon cover connectors and pump connectors

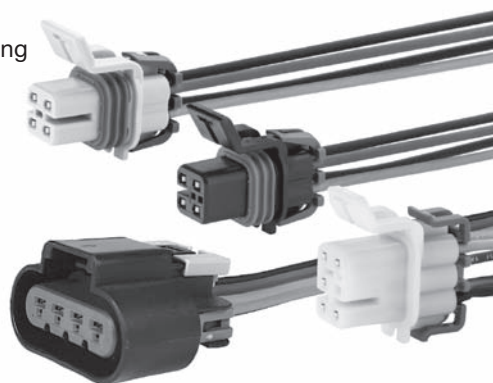

Special addendum to GM vehicle to module wiring harness

GM announced a wiring harness recall in 2005 regarding the Suburban model years 2000-2001. However, GM has issued a dealer bulletin to repair Metri-Pac® 150 connectors on the following trucks and SUVs:

- 1999-2003 Cadillac Escalade
- 1996-2001 Chevrolet Suburban
- 1996-2003 Chevrolet Silverado, Tahoe
- 1996-2001 GMC Suburban, Yukon XL
- 1996-2003 GMC Sierra, Yukon, 1500 Series only:

Excludes: E85 Flexible Fuel Vehicles (VIN Z – RPO L59), Diesel Vehicles VINs F, S, Y, 1 – RPOs L65, L56, L57, LB7

Ask your NAPA Fuel Pumps representative for the latest information on upgraded harness connector options.

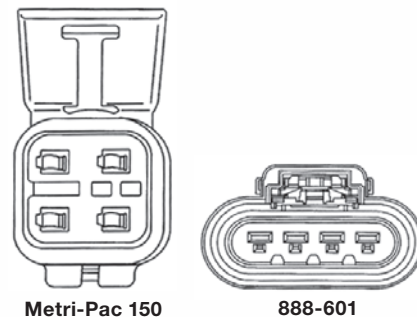

NAPA TECH LINE

Our tech line is manned by ASE-Certified technical service engineers who are very knowledgeable about fuel system repair and the NAPA fuel product line.

For FAST AND EASY fuel system technical information, call:

800-568-6664



NAPA ONLINE

www.NAPAFuelPumps.com

provides complete fuel system solutions for the professional and do-it-yourselfer. It offers comprehensive information on proper fuel system diagnosis and fuel pump installation in both printed and video format. The website also reviews in detail the full line of NAPA fuel pumps and accessories, including CleanScreen™ filters.



TEC Bulletins: Informative, how-to facts on proper fuel system diagnosis and installation.

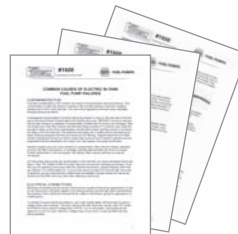

Fuel Tech Solutions: Professional-based product bulletins that address many of the problems technicians regularly face.



Instructive

Videos and Charts: Providing easy-to-follow methods on how to perform proper fuel system service.

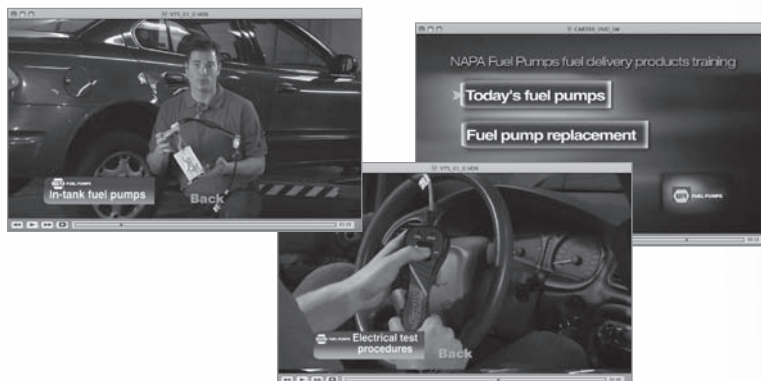

FUEL PUMPS



100% Factory Tested

Assembled on the ultra-modern lines of ISO/QS/TS certified facilities, NAPA Fuel Pumps measure up to the most rigid standards. Each is factory tested to assure performance too.

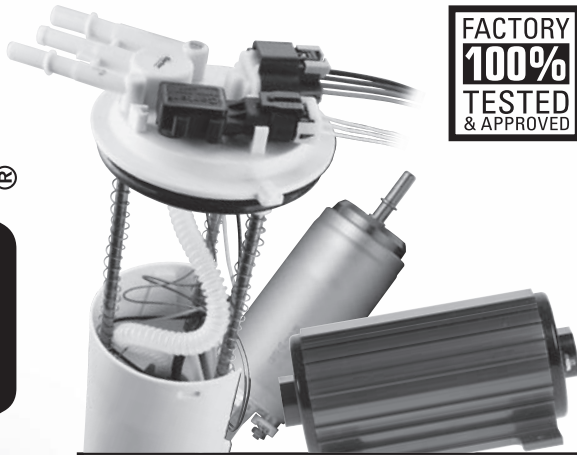

**FACTORY
100%
TESTED
& APPROVED**

All NAPA Fuel Pumps are 100% factory tested.



1991-1995
Chrysler Minivans
P74634M

TOTAL QUALITY CHECK

A full battery of tests, during and after the assembly process, makes sure each NAPA pump is ready to deliver dependable service.

As the pump unit is assembled:

Each pumping mechanism's roller assembly (a gear and several rollers sandwiched between two metal plates) is tested by machine-spinning it from the bottom.



After pump unit is assembled:

Inspectors connect each pump to a power

source and run fluid through to test the pumping action.



Inspectors then check for proper flow and pressure.

After hanger is assembled:

A computer checks each sender's accuracy.

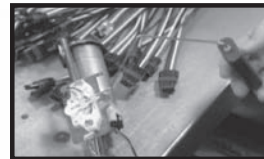

EST	GRAPH	LEVEL	UNIT	TIME
EMPTY	STOP	11.70	0.00	00:00
EMPTY	TASK	0.00	0.00	00:00
1/4	TASK	00.70	0.00	00:00
1/2	TASK	00.00	0.00	00:00
3/4	TASK	00.00	0.00	00:00