

**AUTOPRO™ 20**For use with machines having Code Number: **11971****Safety Depends on You**

Marquette® arc welding and cutting equipment is designed and built with safety in mind. However, your overall safety can be increased by proper installation ... and thoughtful operation on your part. **DO NOT INSTALL, OPERATE OR REPAIR THIS EQUIPMENT WITHOUT READING THIS MANUAL AND THE SAFETY PRECAUTIONS CONTAINED THROUGHOUT.** And, most importantly, think before you act and be careful.

**OPERATOR'S MANUAL**

**MARQUETTE**  
BY **LINCOLN**  
ELECTRIC

## ! WARNING

PLASMA CUTTING or GOUGING can be hazardous.

**PROTECT YOURSELF AND OTHERS FROM POSSIBLE SERIOUS INJURY OR DEATH. KEEP CHILDREN AWAY. PACEMAKER WEARERS SHOULD CONSULT WITH THEIR DOCTOR BEFORE OPERATING.**

Read and understand the following safety highlights. For additional safety information it is strongly recommended that you purchase a copy of "Safety in Welding & Cutting - ANSI Standard Z49.1" from the American Welding Society, P.O. Box 351040, Miami, Florida 33135 or CSA Standard W117.2.

**BE SURE THAT ALL INSTALLATION, OPERATION, MAINTENANCE, AND REPAIR PROCEDURES ARE PERFORMED ONLY BY QUALIFIED INDIVIDUALS.**



### ELECTRIC SHOCK can kill.

- 1.a. The electrode and work (or ground) circuits are electrically "hot" when the power source is on. Do not touch these "hot" parts with your bare skin or wet clothing. Wear dry, hole-free gloves to insulate hands.
- 1.b. When the power source is operating voltages in excess of 250 volts are produced. This creates the potential for serious electrical shock - potentially even fatal.
- 1.c. Insulate yourself from work and ground using dry insulation. When cutting or gouging in damp locations, on metal framework such as floors, gratings or scaffolds and when in positions such as sitting or lying, make certain the insulation is large enough to cover your full area of physical contact with work and ground.
- 1.d. Always be sure the work cable makes a good electrical connection with the metal being cut or gouged. The connection should be as close as possible to the area being cut or gouged.
- 1.e. Ground the work or metal to be cut or gouged to a good electrical (earth) ground.
- 1.f. Maintain the plasma torch, cable and work clamp in good, safe operating condition. Replace damaged insulation.
- 1.g. Never dip the torch in water for cooling or plasma cut or gouge in or under water.
- 1.h. When working above floor level, protect yourself from a fall should you get a shock.
- 1.i. Operate the pilot arc with caution. The pilot arc is capable of burning the operator, others or even piercing safety clothing.
- 1.j. Also see Items 4c and 6.



### ARC RAYS can burn.

- 2.a. Use safety glasses and a shield with the proper filter and cover plates to protect your eyes from sparks and the rays of the arc when performing or observing plasma arc cutting or gouging. Glasses, headshield and filter lens should conform to ANSI Z87.1 standards.
- 2.b. Use suitable clothing including gloves made from durable flame-resistant material to protect your skin and that of your helpers from the arc rays.
- 2.c. Protect other nearby personnel with suitable non-flammable screening and/or warn them not to watch the arc nor expose themselves to the arc rays or to hot spatter or metal.



### FUMES AND GASES can be dangerous.

- 3.a. Plasma cutting or gouging may produce fumes and gases hazardous to health. Avoid breathing these fumes and gases. When cutting or gouging, keep your head out of the fumes. Use enough ventilation and/or exhaust at the arc to keep fumes and gases away from the breathing zone. **When plasma cutting or gouging on lead or cadmium plated steel and other metals or coatings which produce highly toxic fumes keep exposure as low as possible and below Threshold Limit Values (TLV) using local exhaust or mechanical ventilation. In confined spaces or in some circumstances, outdoors, a respirator may be required. Additional precautions are also required when plasma cutting or gouging on galvanized steel.**
- 3.b. The operation of plasma cutting or gouging fume control equipment is affected by various factors including proper use and positioning of the equipment, maintenance of the equipment and the specific procedure and application involved. Worker exposure level should be checked upon installation and periodically thereafter to be certain it is within applicable OSHA PEL and ACGIH TLV limits.
- 3.c. Do not use plasma cutting or gouging equipment in locations near chlorinated hydrocarbon vapors coming from degreasing, cleaning or spraying operations. The heat and rays of the arc can react with solvent vapors to form phosgene, a highly toxic gas, and other irritating products.
- 3.d. Gases used for plasma cutting and gouging can displace air and cause injury or death. Always use enough ventilation, especially in confined areas, to insure breathing air is safe.
- 3.e. Read and understand the manufacturer's instructions for this equipment and follow your employer's safety practices.



### CUTTING SPARKS can cause fire or explosion.

- 4.a. Remove fire hazards from the plasma cutting or gouging area. If this is not possible, cover them to prevent the cutting or gouging sparks from starting a fire. Remember that welding sparks and hot materials from plasma cutting or gouging can easily go through small cracks and openings to adjacent areas. Avoid cutting or gouging near hydraulic lines. Have a fire extinguisher readily available.
- 4.b. Where compressed gases are to be used at the job site, special precautions should be used to prevent hazardous situations. Refer to "Safety in Welding and Cutting" (ANSI Standard Z49.1) and the operating information for the equipment being used.

- 4.c. When not cutting or gouging, make certain no part of the electrode circuit is touching the work or ground. Accidental contact can cause overheating and create a fire hazard.
- 4.d. Do not cut or gouge tanks, drums or containers until the proper steps have been taken to insure that such procedures will not cause flammable or toxic vapors from substances inside. They can cause an explosion even though they have been "cleaned." For information purchase "Recommended Safe Practices for the Preparation for Welding and Cutting of Containers and Piping That Have Held Hazardous Substances", AWS F4.1 from the American Welding Society (see address above).
- 4.e. Vent hollow castings or containers before heating, cutting or gouging. They may explode.
- 4.f. Do not fuel engine driven equipment near area where plasma cutting or gouging.
- 4.g. Sparks and spatter are thrown from the plasma arc. Wear safety glasses, ear protection and oil free protective garments such as leather gloves, heavy shirt, cuffless trousers, high shoes and a cap over your hair. Wear ear plugs when cutting or gouging out of position or in confined places. Always wear safety glasses with side shields when in a cutting or gouging area.
- 4.h. Connect the work cable to the work as close to the cutting or gouging area as practical. Work cables connected to the building framework or other locations away from the cutting or gouging area increase the possibility of the current passing through lifting chains, crane cables or other alternate circuits. This can create fire hazards or overheat lifting chains or cables until they fail.
- 4.i. Read and follow NFPA 51B "Standard for Prevention During Welding, Cutting and Other Hot Work", available from NFPA, 1 Batterymarch Park, PO box 9101, Quincy, Ma 022690-9101.



### CYLINDER may explode if damaged.

- 5.a. Use only compressed gas cylinders containing the correct gas for the process used and properly operating regulators designed for the gas and pressure used. All hoses, fittings, etc. should be suitable for the application and maintained in good condition.
- 5.b. Always keep cylinders in an upright position securely chained to an undercarriage or fixed support.
- 5.c. Cylinders should be located:
  - Away from areas where they may be struck or subjected to physical damage.
  - A safe distance from plasma cutting or gouging, arc welding operations and any other source of heat, sparks, or flame.
- 5.d. Never allow any part of the electrode, torch or any other electrically "hot" parts to touch a cylinder.
- 5.e. Keep your head and face away from the cylinder valve outlet when opening the cylinder valve.
- 5.f. Valve protection caps should always be in place and hand tight except when the cylinder is in use or connected for use.
- 5.g. Read and follow the instructions on compressed gas cylinders, associated equipment, and CGA publication P-1, "Precautions for Safe Handling of Compressed Gases in Cylinders," available from the Compressed Gas Association 1235 Jefferson Davis Highway, Arlington, VA 22202.



### FOR ELECTRICALLY powered equipment.

- 6.a. Turn off input power using the disconnect switch at the fuse box before working on the equipment.
- 6.b. Install equipment in accordance with the U.S. National Electrical Code, all local codes and the manufacturer's recommendations.
- 6.c. Ground the equipment in accordance with the U.S. National Electrical Code and the manufacturer's recommendations.

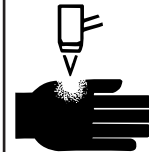

### PLASMA ARC can injure.

- 7.a. Keep your body away from nozzle and plasma arc.
- 7.b. Operate the pilot arc with caution. The pilot arc is capable of burning the operator, others or even piercing safety clothing.



### ELECTRIC AND MAGNETIC FIELDS may be dangerous

- 8.a. Electric current flowing through any conductor causes localized Electric and Magnetic Fields (EMF). Cutting or gouging current creates EMF fields around torch cables and cutting machines.
- 8.b. EMF fields may interfere with some pacemakers, so operators having a pacemaker should consult their physician before cutting or gouging.
- 8.c. Exposure to EMF fields during cutting or gouging may have other health effects which are now not known.
- 8.d. All operators should use the following procedures in order to minimize exposure to EMF fields from the cutting or gouging circuit:
  - 8.d.1. Route the torch and work cables together - Secure them with tape when possible.
  - 8.d.2. Never coil the torch cable around your body.
  - 8.d.3. Do not place your body between the torch and work cables. If the torch cable is on your right side, the work cable should also be on your right side.
  - 8.d.4. Connect the work cable to the workpiece as close as possible to the area being cut or gouged.
  - 8.d.5. Do not work next to cutting power source.

# NOTES

## PRÉCAUTIONS DE SÛRETÉ

Pour votre propre protection lire et observer toutes les instructions et les précautions de sûreté spécifiques qui paraissent dans ce manuel aussi bien que les précautions de sûreté générales suivantes:

### Sûreté Pour Soudage A L'Arc

1. Protégez-vous contre la secousse électrique:
  - a. Les circuits à l'électrode et à la pièce sont sous tension quand la machine à souder est en marche. Éviter toujours tout contact entre les parties sous tension et la peau nue ou les vêtements mouillés. Porter des gants secs et sans trous pour isoler les mains.
  - b. Faire très attention de bien s'isoler de la masse quand on soude dans des endroits humides, ou sur un plancher métallique ou des grilles métalliques, principalement dans les positions assis ou couché pour lesquelles une grande partie du corps peut être en contact avec la masse.
  - c. Maintenir le porte-électrode, la pince de masse, le câble de soudage et la machine à souder en bon et sûr état de fonctionnement.
  - d. Ne jamais plonger le porte-électrode dans l'eau pour le refroidir.
  - e. Ne jamais toucher simultanément les parties sous tension des porte-électrodes connectés à deux machines à souder parce que la tension entre les deux pinces peut être le total de la tension à vide des deux machines.
  - f. Si on utilise la machine à souder comme une source de courant pour soudage semi-automatique, ces précautions pour le porte-électrode s'appliquent aussi au pistolet de soudage.
2. Dans le cas de travail au dessus du niveau du sol, se protéger contre les chutes dans le cas où on reçoit un choc. Ne jamais enrouler le câble-électrode autour de n'importe quelle partie du corps.
3. Un coup d'arc peut être plus sévère qu'un coup de soleil, donc:
  - a. Utiliser un bon masque avec un verre filtrant approprié ainsi qu'un verre blanc afin de se protéger les yeux du rayonnement de l'arc et des projections quand on soude ou quand on regarde l'arc.
  - b. Porter des vêtements convenables afin de protéger la peau de soudeur et des aides contre le rayonnement de l'arc.
  - c. Protéger l'autre personnel travaillant à proximité au soudage à l'aide d'écrans appropriés et non-inflammables.
4. Des gouttes de laitier en fusion sont émises de l'arc de soudage. Se protéger avec des vêtements de protection libres de l'huile, tels que les gants en cuir, chemise épaisse, pantalons sans revers, et chaussures montantes.

5. Toujours porter des lunettes de sécurité dans la zone de soudage. Utiliser des lunettes avec écrans latéraux dans les zones où l'on pique le laitier.
6. Eloigner les matériaux inflammables ou les recouvrir afin de prévenir tout risque d'incendie dû aux étincelles.
7. Quand on ne soude pas, poser la pince à un endroit isolé de la masse. Un court-circuit accidentel peut provoquer un échauffement et un risque d'incendie.
8. S'assurer que la masse est connectée le plus près possible de la zone de travail qu'il est pratique de le faire. Si on place la masse sur la charpente de la construction ou d'autres endroits éloignés de la zone de travail, on augmente le risque de voir passer le courant de soudage par les chaînes de levage, câbles de grue, ou autres circuits. Cela peut provoquer des risques d'incendie ou d'échauffement des chaînes et des câbles jusqu'à ce qu'ils se rompent.
9. Assurer une ventilation suffisante dans la zone de soudage. Ceci est particulièrement important pour le soudage de tôles galvanisées plombées, ou cadmiées ou tout autre métal qui produit des fumées toxiques.
10. Ne pas souder en présence de vapeurs de chlore provenant d'opérations de dégraissage, nettoyage ou pistolage. La chaleur ou les rayons de l'arc peuvent réagir avec les vapeurs du solvant pour produire du phosgène (gas fortement toxique) ou autres produits irritants.
11. Pour obtenir de plus amples renseignements sur la sûreté, voir le code "Code for safety in welding and cutting" CSA Standard W 117.2-1974.

## PRÉCAUTIONS DE SÛRETÉ POUR LES MACHINES À SOUDER À TRANSFORMATEUR ET À REDRESSEUR

1. Relier à la terre le chassis du poste conformément au code de l'électricité et aux recommandations du fabricant. Le dispositif de montage ou la pièce à souder doit être branché à une bonne mise à la terre.
2. Autant que possible, l'installation et l'entretien du poste seront effectués par un électricien qualifié.
3. Avant de faire des travaux à l'intérieur de poste, la débrancher à l'interrupteur à la boîte de fusibles.
4. Garder tous les couvercles et dispositifs de sûreté à leur place.

# Thank You

for selecting one of our **QUALITY** products. We want you to take pride in operating this product ••• as much pride as we have in bringing this product to you!

## CUSTOMER ASSISTANCE POLICY

The business of our company is manufacturing and selling high quality welding equipment. Our challenge is to meet the needs of our customers and to exceed their expectations. On occasion, purchasers may ask us for advice or information about their use of our products. We respond to our customers based on the best information in our possession at that time. We are not in a position to warrant or guarantee such advice, and assume no liability, with respect to such information or advice. We expressly disclaim any warranty of any kind, including any warranty of fitness for any customer's particular purpose, with respect to such information or advice. As a matter of practical consideration, we also cannot assume any responsibility for updating or correcting any such information or advice once it has been given, nor does the provision of information or advice create, expand or alter any warranty with respect to the sale of our products.

We are a responsive manufacturer, but the selection and use of specific products sold by us is solely within the control of, and remains the sole responsibility of the customer. Many variables beyond our control affect the results obtained in applying these types of fabrication methods and service requirements.

Subject to Change – This information is accurate to the best of our knowledge at the time of printing.

## **Please Examine Carton and Equipment For Damage Immediately**

When this equipment is shipped, title passes to the purchaser upon receipt by the carrier. Consequently, Claims for material damaged in shipment must be made by the purchaser against the transportation company at the time the shipment is received.

Please record your equipment identification information below for future reference. This information can be found on your machine nameplate.

Product \_\_\_\_\_

Model Number \_\_\_\_\_

Code Number or Date Code (if available) \_\_\_\_\_

Serial Number (if available) \_\_\_\_\_

Date Purchased \_\_\_\_\_

Where Purchased \_\_\_\_\_

Whenever you request replacement parts or information on this equipment, always supply the information you have recorded above.

**Read this Operators Manual completely** before attempting to use this equipment. Save this manual and keep it handy for quick reference. Pay particular attention to the safety instructions we have provided for your protection. The level of seriousness to be applied to each is explained below:

### **WARNING**

This statement appears where the information **must** be followed **exactly** to avoid **serious personal injury** or **loss of life**.

### **CAUTION**

This statement appears where the information **must** be followed to avoid **minor personal injury** or **damage to this equipment**.

	Page
<b>Installation.....</b>	<b>Section A</b>
Technical Specifications .....	A-1
Safety Precautions .....	A-2
Select Proper Location .....	A-2
Stacking .....	A-2
Tilting .....	A-2
High Frequency Interference Protection .....	A-2
Input Electrical Connections .....	A-2
Compressed Air or Gas Input Connections .....	A-3
Connections to Ground Cable .....	A-3
Torch Connections .....	A-3
<hr/>	
<b>Operation.....</b>	<b>Section B</b>
Safety Precautions .....	B-1
Description .....	B-1
User Responsibility .....	B-2
Design Features and Advantages .....	B-2
Cutting Capability .....	B-2
Torch Consumables .....	B-2
Limitations .....	B-2
Controls and Settings .....	B-2
Cutting Operations .....	B-3
Check Air Quality .....	B-3
Cutting with a Hand Torch .....	B-3, B-4
Pilot Arc Discussion .....	B-5
Torch Consumable Parts Selection .....	B-5
<hr/>	
<b>Maintenance .....</b>	<b>Section D</b>
Safety Precautions .....	D-1
Routine Maintenance .....	D-1
Periodic Maintenance .....	D-1
Compressed Air Filter .....	D-2
<hr/>	
<b>Troubleshooting .....</b>	<b>Section E</b>
Safety Precautions .....	E-1
How to Use Troubleshooting Guide .....	E-1
Troubleshooting Guide .....	E-2
<hr/>	
<b>Wiring Diagrams .....</b>	<b>Section F</b>
Wiring Diagram .....	F-1
<hr/>	
<b>Parts Lists .....</b>	<b>P-723 Series</b>
<hr/>	



**TECHNICAL SPECIFICATIONS - AUTOPRO™ 20**

<b>INPUT - SINGLE PHASE</b>				
<b>Standard Voltage</b> 115/1/50/60Hz (15 Amp Branch) 115/1/50/60Hz (20 Amp Branch with 20 Amp Plug*)		<b>1Ø Input Current at Rated Output</b> 115 V: 20A @ 50% 115 V: 26A @ 40%		
<b>RATED OUTPUT</b>				
<b>Duty Cycle</b>		<b>AMPS</b>		
50% on 115V (15 Amp Branch) 40% on 115V (20 Amp Branch with 20 Amp Plug*)		15 A 20 A		
<b>OUTPUT</b>				
<b>Current Range</b> 10-20 Amps		<b>Open Circuit Voltage</b> 310 VDC		<b>Pilot Current</b> 17 Amps
<b>REQUIRED AIR FLOW RATE</b>		<b>REQUIRED AIR INLET PRESSURE</b>		
3.5 cu. ft./min. (100L/min.)		72.5 to 150 PSI ( 5 Bar TO 10.3 Bar)		
<b>RECOMMEND INPUT WIRE AND FUSE SIZES</b>				
For all plasma cutting applications Based on U.S. National Electrical Code Ambient Temperature 30°C or Less				
Output	AC Input Voltage at 50/60 Hertz	Plug Size	Maximum Time-Delay Circuit Breaker or Fuse Size	Type SJT or Hard Usage Input Cord
20 A	115V-1Ø	5-20P*	20 AMPS	3 Conductor, #14 AWG
15 A	115V-1Ø	5-15P	15 Amps	
<b>PHYSICAL DIMENSIONS</b>				
<b>Height</b> 12 in. 305 mm		<b>Width</b> 6 in. 152 mm		<b>Weight Including Torch Cable</b> 21 lbs. 9.5 kg.
			<b>Depth</b> 16 in. 406 mm	

\*5-20P plug must comply with the standard for attachment plugs and receptacles, UL498.



Read entire Installation Section before installing the AUTOPRO™ 20.

## SAFETY PRECAUTIONS

### ⚠ WARNING

#### ELECTRIC SHOCK CAN KILL.



- Only qualified personnel should perform this installation.
- Only personnel that have read and understood the AUTOPRO™ 20 Operating Manual should install and operate this equipment.
- Machine must be plugged into a receptacle which is grounded per any national, local or other applicable electrical codes.
- The AUTOPRO™ 20 power switch is to be in the OFF (“O”) position when installing work cable and gun and when connecting power cord to input power.

#### SELECT PROPER LOCATION

Place the AUTOPRO™ 20 where clean cool air can freely circulate in and out the front, rear and side louvers. Dirt, dust, smoke, gas or any foreign material that can be drawn into the machine should be kept at a minimum. Insure open space of at least 15 ft. around the machine. Failure to observe these precautions can result in excessive operating temperatures and nuisance shutdown of the machine.

#### STACKING

The AUTOPRO™ 20 cannot be stacked.

#### TILTING

The AUTOPRO™ 20 must be placed on a stable, level surface so it will not topple over.

#### HIGH FREQUENCY INTERFERENCE PROTECTION

The AUTOPRO™ 20 employs a touch start mechanism for arc initiation which eliminates high frequency emissions from the machine as compared with spark gap and solid state type high frequency generators. Keep in mind, though, that these machines may be used in an environment where other high frequency generating machines are operating. By taking the following steps, high frequency interference into the AUTOPRO™ 20 can be minimized.

- (1) Make sure the power supply chassis is connected to a good earth ground. The work terminal ground does NOT ground the machine frame.
- (2) Keep the work clamp isolated from other work clamps that have high frequency.
- (3) If the work clamp cannot be isolated, then keep the clamp as far as possible from other work clamp connections.
- (4) When the machine is enclosed in a metal building, several good earth driven electrical grounds around the periphery of the building are recommended.

Failure to observe these recommended installation procedures may cause improper function of the AUTOPRO™ 20 or possibly even damage to the control system or power supply components.

#### INPUT ELECTRICAL CONNECTIONS

The AUTOPRO™ 20 must be connected to a Line-Neutral system with protective grounding wire. Check that the relevant electrical outlet is actually connected to the distribution system grounding.

The AUTOPRO™ 20 is rated for 115VAC input.

Use on 15 amp branch circuits will limit cutting output. When the output is set at 16 amps or greater, the input fuse or circuit breaker may “blow” in roughly 30 seconds or less (depending on fuse or circuit breaker type).

To achieve 16-20 amp output with 115VAC input, replace the 15 amp plug on the input cord with a 20 amp plug, and connect the unit to a 20 amp branch circuit with super lag fuses (or equivalent breaker). To install 20 amp plug: Connect the white (neutral) wire under terminal clamp with silver screw, and black (hot) wire under terminal clamp with brass screw. Connect green wire under terminal clamp with green screw. Tighten terminal wire clamp screws securely.

5-20P plug must comply with the standard for attachment plugs and receptacles, UL498. This product is acceptable for use only when an attachment plug as specified is properly attached to the supply cord.

### ⚠ WARNING

- Failure to wire as instructed may cause personal injury or damage to equipment.
- To be installed or checked by an electrician or qualified person only.

Use of normal 20 amp household breakers may result in over current trips. If breaker trips occur, reduce the cutting current output until nuisance trips stop.

## COMPRESSED AIR OR GAS INPUT CONNECTION

A source of clean, dry air or nitrogen must be supplied to the AUTOPRO™ 20. Oil in the air is a severe problem and must be avoided. The supply pressure must be between 72.5 and 150 psi (5 and 10.3 bar). The flow rate is approximately 3.5 cu. ft./min. (100L/min.). Failure to observe these precautions could result in excessive operating temperatures or damage to the torch.

### ⚠ WARNING

Air with considerable quantity of humidity or oil may cause an excessive wear of the parts or even damage the torch.

If there are any doubts about the quality of the compressed air available, it is suggested that an air dryer be installed before the input filter. Using flexible airline, connect the compressed air to the rear of the machine. Do not exceed maximum entry pressure of 150 PSI (10.3 Bar). The pressure must be adjusted to 72.5 PSI (5 Bar), minimum.

- To use the air fitting supplied with the machine apply teflon tape to the fitting threads and install the fitting in the port at the rear of the machine.

**NOTE:** When using nitrogen gas from a cylinder, the cylinder must have a pressure regulator.

- Maximum psi from a nitrogen gas cylinder to the AUTOPRO™ 20 regulator should never exceed 150 psi (10.3 Bar).
- Install a hose between the nitrogen gas cylinder regulator and the AUTOPRO™ 20 gas inlet.

### ⚠ WARNING

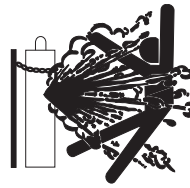

**CYLINDER** could explode if damaged.

- Keep cylinder upright and chained to a fixed support.
- Keep cylinder away from areas where it could be damaged.
- Never lift machine with cylinder attached.
- Never allow the cutting torch to touch the cylinder.
- Keep cylinder away from live electrical parts.
- Maximum inlet pressure 150 PSI (10.3 Bar).

## CONNECTION TO GROUND CABLE

Connect the work cable clamp to the piece to be cut or to the metallic workbench. Take the following precautions:

Verify that there is a good electrical contact particularly if insulated or oxidated coated sheets are cut.

Make ground connections as close as possible to the cutting area. The use of the metallic structures which are not part of the workpiece, such as return cable of the cutting current, may endanger the safety system and give poor cutting results.

Do not make a ground connection on the piece which is to be cut off.

## TORCH CONNECTION

**Before starting the cutting operations verify that the parts are properly assembled by inspecting the head of the torch as shown in the “Operations Section”(Torch Consumable Parts).**

Read and understand this entire section before operating the machine.

## SAFETY PRECAUTIONS

**⚠ WARNING****ELECTRIC SHOCK  
can kill.**

- Do not touch electrically live parts or electrode with skin or wet clothing.
- Insulate yourself from work and ground.
- Always wear dry insulating gloves.

**FUMES AND GASES  
can be dangerous.**

- Keep your head out of fumes.
- Use ventilation or exhaust to remove fumes from breathing zone.

**WELDING, CUTTING and  
GOUGING SPARKS  
can cause fire or explosion**

- Keep flammable material away.
- Do not weld, cut or gouge on containers that have held combustibles.

**ARC RAYS  
can burn.**

- Wear eye, ear and body protection.

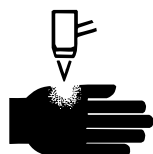
**PLASMA ARC can injure**

- Keep your body away from nozzle and plasma arc.
- Operate the pilot arc with caution. The pilot arc is capable of burning the operator, others or even piercing safety clothing.

Observe additional Safety Guidelines detailed in the beginning of this manual.

## DESCRIPTION

The AUTOPRO™ 20 is a constant current, continuous control plasma cutter power source.

The AUTOPRO™ 20 comes standard with an air regulator and pressure gauge. The unit is powered from a 115Vac, 20 amp input circuit with a 40% duty cycle rating on a 10 minute basis, with 20 amp output. The unit includes a hand-held torch with consumables and a work cable with clamp.

The AUTOPRO™ 20 utilizes a 3 second delay after pressing the trigger before arc initiation to ensure that the operator is ready. The unit will not function if consumables are not installed correctly or missing, protecting the user. The unit uses pneumatic-action for arc initiation and does not use high-frequency.

Plasma is a gas that is heated to an extremely high temperature and ionized so that it becomes a conductor of electricity.

This cutting procedure utilizes the plasma to transfer the electric arc to the metal workpiece. The arc melts a small amount of the work piece and the compressed air blows away the molten metal there by producing the cutting action.

The torch uses compressed air from a single source, for both the plasma, cooling and protective gas.

The start of the cycle is determined by an arc, called the pilot arc, which is struck between the moveable electrode (negative polarity) and the torch nozzle (positive polarity) due to a short circuit between these two elements.

When the torch is brought near the workpiece to be cut and the trigger is pressed the pilot arc is transferred between the electrode and the workpiece thus striking a plasma arc, also called the cutting arc.

The duration of the pilot arc is set in the factory at 3 seconds; if the transfer has not been made within this time, the cycle is automatically stopped except for the cooling air which is kept on.

## USER RESPONSIBILITY

Variation such as plate chemistry, plate surface condition (oil, scale), plate thickness, preheat, quench, gas type, gas flow rate and equipment may produce results different than those expected. Some adjustments to procedures may be necessary to compensate for unique individual conditions. Test all procedures duplicating actual field conditions.

## DESIGN FEATURES AND ADVANTAGES

- Light weight
- Continuous output control
- Indicator LEDs
- Cooling fan
- Rapid arc restrike for cutting across gaps
- 3 second arc delay for safety
- Adjustable air pressure regulator with locking feature
- Part-in-place verification for safety and proper operation
- Thermostatic protection with thermal indication
- Air inlet filter with water purge button to protect air path and torch
- Lighted ON/OFF switch
- High input voltage protection

## CUTTING CAPABILITY

The AUTOPRO™ 20 is rated for 20A @ 40% duty cycle. The unit is designed to cut up to 3/8" inch mild steel, but has the capability to cut other metals such as stainless and aluminum (travel speed will vary).

## TORCH CONSUMABLES

The torch consumables consist of an Electrode, Gas Distributor Ring, Nozzle, and Shield Cup. The consumable parts must be placed in the correct order and secured properly for the unit to operate.

## LIMITATIONS

- For indoor use only.
- Do not exceed output current and duty cycle rating of machine. Do not use the AUTOPRO™ 20 for pipe thawing.
- Do not power with **generators** or **engine drives**.

## CONTROLS AND SETTINGS

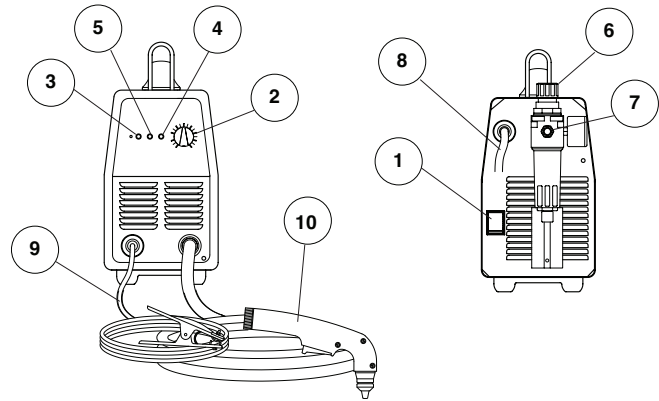

1. **ON/OFF Switch** – In the ON position the machine is ready for normal operation. All system control circuits are activated. OFF position deactivates control circuits.
2. **Output Current Knob**–Adjusts the cutting current supplied by the machine according to the thickness of material/speed.
3. **Green LED** – Turns ON when input voltage is applied within normal range – blinks slowly when input voltage goes above 130Vac, or below 95Vac.
4. **Red LED** – Turns ON when torch is triggered Blinks quickly during 3 second safety pre-flow prior to pilot arc ignition Blinks slowly if cutting arc is not initiated after 3 second pilot arc ignition.
5. **Yellow LED** – Turns ON when the thermal protection is activated. Blinks slowly when the under pressure protection is working (the pressure is under 55 PSI, 3.8 Bar)
6. **Air Regulator** – Adjusts the input air pressure – pull upward to unlock, press down to lock – nominal air pressure setting is 65 PSI, 4.5 Bar.  
Note: Regulator should never be set above 87 PSI (6 Bar).
7. **Compressed Air Connection**
8. **Input Cord**
9. **Work cable with clamp**
10. **Torch**

## CUTTING OPERATIONS

### BEFORE CUTTING

#### ⚠ WARNING



**ELECTRIC SHOCK CAN KILL.**  
Disconnect input power by removing the plug from the receptacle before assembling or disassembling torch parts, or torch and lead assemblies.

Check and follow instructions listed in the "Safety and Installation" section of this manual.

### TORCH PARTS

Check the torch for proper assembly. Install proper torch parts for the desired application (refer to the Torch Consumable Parts Selection Section).

NOTE: The power supply will not operate unless the torch shield cup is fully seated against the PIP (Parts in Place) pins in the torch head.

### INPUT POWER

Check the power source for proper input voltage. Make sure the power source meets circuit protection and wiring requirements. Plug in power cord to supply input power to the unit.

### GROUND CABLE

Check for a solid ground cable connection to the workpiece.

### AUTOMATIC PURGE SYSTEM

Place the ON/OFF switch to the ON position. If the line voltage is OK, the green LED will turn on. Activate the torch trigger to initiate air purge. There will be a 3 second delay to remove any condensation that may have accumulated in the torch and air lines while the system was shut down. When the air purge (Air safety time) is complete, pilot arc will be initiated.

FIGURE B.1

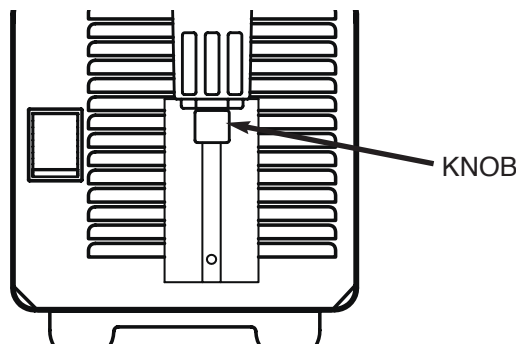

## CHECKING AIR QUALITY

To check air quality, deactivate the torch (post-flow) and place a welding filter lens in front of the torch. Any oil or moisture in the air will be visible on the lens. **DO NOT** initiate pilot arc while checking air quality.

When preparing to cut, position the machine as close to the work as possible. Make sure you have all materials needed to complete the job and have taken all safety precautions. It is important to follow these operating steps each time you use the machine.

#### • COMPRESSED AIR

The AUTOPRO™ 20 requires compressed air to be attached to the unit. The input air pressure minimum must be 72.5 PSI, 5 Bar and must not exceed 150 PSI, 10.3 Bar. An air regulator is included with the unit with optimum pressure setting set to 65 PSI, 4.5 Bar.

The unit is also equipped with an air filter which captures water and oil vapor. The vapor collected can be drained out of the bottom of the unit by turning the drain button. The unit will not operate if the input air pressure is below 55 PSI, 3.8 Bar.

Three Position Drain knob: (See Figure B.1)

1. Open
2. Open when no air pressure, closed when air pressure.
3. Closed

## CUTTING WITH A HAND TORCH

- Turn the main power and the machine power switch on.
  - The fan should start.
  - The pre-charge circuit will operate for 3 seconds, then the green "Power" LED should turn on.
- Be sure that the work lead is clamped to the workpiece before cutting.
- Set the output current control knob at maximum position for higher cutting speed and less dross formation. Reduce the current, if desired to reduce the kerf (cut) width, heat affected zone or travel speed as required.



- When ready to cut, place the torch near the work, make certain all safety precautions have been taken and pull the trigger.
  - The air will flow for a preflow time of 3 seconds and the pilot arc will start.
  - The pilot arc will run for 3.0 seconds and shut off unless the arc is brought in contact with the work and the arc is transferred. Avoid excessive pilot arc time by transferring the arc to the workpiece quickly.
  - When the arc is brought within 1/8" - 1/4" from the work piece: the arc will transfer, the current will ramp to the setting on the control panel, and the cut can last indefinitely (or until the duty cycle of the unit is exceeded).
- Pierce the work piece by slowly lowering the torch onto the metal at a 30° angle away from the operator. This will blow the dross away from the torch nozzle. Slowly rotate the torch to vertical position as the arc becomes deeper.

**NOTE:** Graphics shown are for understanding torch angles for best results – the distances from the work piece are exaggerated. In actual operation, the nozzle should be held just above the work piece surface.

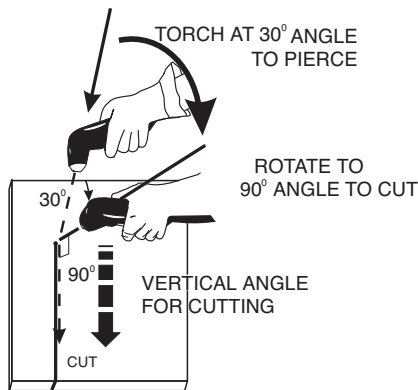

- Keep moving while cutting. Cut at a steady speed without pausing. Maintain the cutting speed so that the arc lag is 10° to 20° behind the travel direction.

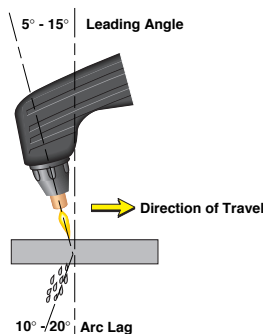

- Use a 5° - 15° leading angle in the direction of the cut.
- Finish the cut to be made and release the trigger.

**NOTE:** For better torch control, it is acceptable to let the nozzle drag along the work piece surface. This will shorten nozzle life. Also, it is acceptable to place a non-conductive torch guide on the work piece in order to achieve a cleaner cut

- When the trigger is released, the arc will stop.
  - The gas will continue to flow for 20 seconds of postflow. If the trigger is activated within this time period, the pilot arc will restart after the 3 second delay.
- If the dross is difficult to remove, reduce the cutting speed. High speed dross is more difficult to remove than low speed dross.
- The right side of the cut is more square than the left as viewed along the direction of travel.

- Clean spatter and scale from the nozzle frequently.

Parts in place:

- Check the assembly of the torch consumables. If they are not properly in place, the machine will not start. **Make sure that the shield cup is hand tight. Do not use pliers or over tighten.**
- Check the conditions of the inside of the nozzle. If debris has collected, rub the electrode on the inside bottom of the nozzle to remove any oxide layer that may have built up. Refer to the "Routine Maintenance Section".
- Check the condition of the electrode. If the end has a crater-like appearance, replace it along with the nozzle. The maximum wear depth of the electrode is approximately .062". A green and erratic arc will indicate definite electrode failure and the electrode should be replaced immediately.
- Replace the nozzle when the orifice exit is eroded away or oval shaped.

## ⚠ WARNING

**ELECTRIC SHOCK CAN KILL.**  
Disconnect input power by removing the plug from the receptacle before assembling or disassembling torch parts, or torch and lead assemblies.

- If the machine does not reset or continues to trip, consult the Troubleshooting Section.
- Use the proper cutting procedures referred to in Procedure Recommendations.

## PILOT ARC DISCUSSION

The AUTOPRO™ 20 has a smooth, continuous pilot arc. The pilot arc is only a means of transferring the arc to the workpiece for cutting. Repeated pilot arc starts, in rapid succession, is not recommended as these starts will generally reduce consumable life. Occasionally, the pilot arc may sputter or start intermittently. This is aggravated when the consumables are worn or the air pressure is too high. Always keep in mind that the pilot arc is designed to transfer the arc to the workpiece and not for numerous starts without cutting.

When the pilot arc is started, a slight impulse will be felt in the torch handle. This occurrence is normal and is the mechanism which starts the plasma arc. This impulse can also be used to help troubleshoot a "no start" condition.

### ⚠ WARNING



**ELECTRIC SHOCK CAN KILL.**  
Disconnect input power by removing the plug from the receptacle before assembling or disassembling torch parts, or torch and lead assemblies.

Be sure the operator is equipped with proper gloves, clothing, eye and ear protection. Make sure no part of the operator's body comes in contact with the work piece while the torch is activated.

### ⚠ CAUTION

Sparks from the cutting process can cause damage to coated, painted, and other surfaces such as glass, plastic and metal.

**NOTE:** Handle torch cable with care and protect it from damage.

## TORCH CONSUMABLE PARTS SELECTION

To change the torch consumable parts use the following procedure:

**NOTE:** The nozzle, gas distributor, and electrode are held in place by the shield cup. Position the torch with the shield cup facing upward to prevent these parts from falling out when the cup is removed.

1. Unscrew and remove the shield cup from the Torch Head Assembly. Figure B.2 Consumable Parts.
2. Remove the nozzle, gas distributor, and electrode.
3. Install the electrode, gas distributor and nozzle.
4. Hand tighten the shield cup until it is seated on the torch head. If resistance is felt when installing the cup, check the threads before proceeding.

FIGURE B.2

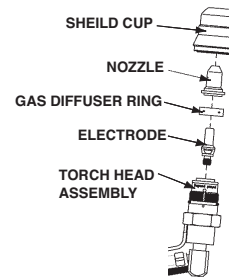

## OPERATING FAULTS

During cutting operations performance faults may arise, such as:

- Insufficient penetration:
  - too high cutting speed;
  - torch is tilted;
  - piece is too thick;
  - cutting current is too low;
  - torch parts are worn out;
  - non-genuine Manufacturer's parts.
- Interruption of the cutting arc:
  - cutting speed too slow;
  - excessive distance between torch and work piece;
  - Input Voltage too low-reduce output current;
  - torch parts are worn out;
  - non-genuine Manufacturer's parts;
  - poor work cable connection/disconnected.
- Excessive slag/dross:
  - too low cutting speed (bottom dross);
  - too high cutting speed (top dross);
  - excessive distance between torch and work piece;
  - cutting current too low;
  - torch parts are worn out;
  - non-genuine Manufacturer's parts.
- Tilted cutting (not perpendicular):
  - torch position not correct;
  - asymmetric wear of nozzle hole and/or incorrect assembly of the torch parts.
- Excessive wear of nozzle and electrodes:
  - air pressure too low;
  - exceeding system capability (material too thick);
  - contaminated air (humidity/oil);
  - excessive pilot arc ignitions in the air;
  - improperly assembled torch;
  - torch nozzle contacting workpiece;
  - damaged or loose torch head components;
  - non-genuine Manufacturer's parts.



**⚠ WARNING**

**ELECTRIC SHOCK** can kill.

- Have a qualified person service this equipment.
- Disconnect input power by removing plug from receptacle before assembling or disassembling torch parts, or torch and lead assemblies.
- Do not touch electrically hot parts.

**ROUTINE MAINTENANCE**

1. Keep the cutting or gouging area and the area around the machine clean and free of combustible materials. No debris should be allowed to collect which could obstruct air flow to the machine.
2. Every 3-4 months or so, the machine should be cleaned with a low pressure airstream. Keeping the machine clean will result in cooler operation and higher reliability. Be sure to clean these areas:
  - Printed circuit boards and heat sinks
  - Power switch

**⚠ CAUTION**

- When using a low pressure airstream, wear appropriate eye protection. Only use dry compressed air for cleaning. Do not point the jet of air at the electronic circuits.

3. Examine the sheet metal case for dents or breakage. Repair the case as required. Keep the case in good condition to insure that high voltage parts are protected and correct spacings are maintained. All external sheet metal screws must be in place to insure case strength and electrical ground continuity.
4. Inspect the cable periodically for any slits or puncture marks in the cable jacket. Replace if necessary. Check to make sure that nothing is crushing the cable and blocking the flow of air through the air tube inside. Also, check for kinks in the cable periodically and relieve any so as not to restrict the flow of air to the torch.
5. Inspect Torch Body and Handle, keep thoroughly clean WITHOUT THE USE OF SOLVENTS. In case of damage replace components for SAFETY CONDITIONS. If repairs cannot be made on site contact a local field service shop.

**PERIODIC MAINTENANCE****⚠ WARNING**

**ELECTRIC SHOCK CAN KILL.**

- Turn off machine and disconnect input power by removing the plug from the receptacle switch before tightening, cleaning or replacing consumables.

Change consumables as required.

**Torch:**

- Periodically according to use, or if experiencing cutting faults, inspect consumable parts associated with the plasma arc.

**Shield Cup:**

- Unscrew manually from the head of the torch. Clean thoroughly and replace if damaged (burns, distortions or cracks).

**Nozzle:**

- Check wear of plasma arc thru-hole and inner & outer surfaces. If thru-hole is widened compared to it's original diameter, replace nozzle. If surfaces are particularly oxidized, clean them with extra fine sand paper.

**Air Distribution Ring:**

- Verify there are no burns or cracks and that air-flow holes are not obstructed. If damaged, replace immediately.

**Electrode:**

- Replace electrode when crater on emitting surface is about .08"(2mm).

**⚠ WARNING**

- Before making any adjustments to the torch, let it cool the entire post-flow time.
- Except for particular cases, it is advised to replace electrode and nozzle AT THE SAME TIME.
- Insure correct assembly order of torch parts.
- Be careful that gas distributor ring is assembled properly.
- Reassemble shield cup screwing it on manually (hand tighten)
- Never assemble shield cup without having included gas distributor ring and nozzle beforehand.
- Timely and appropriate maintenance on torch parts is essential for safety and proper functionality of the cutting system.

---

## COMPRESSED AIR FILTER

The unit is supplied with a filter for the compressed air and fitted with a manual drain for condensation. (Drain is located on the bottom of the filter). Purge periodically to remove the water in the filter by opening the drain knob.

**Do not use solvents to clean the filter; use soapy water only.**

## HOW TO USE TROUBLESHOOTING GUIDE

### WARNING

Service and Repair should only be performed by Lincoln Electric Factory Trained Personnel. Unauthorized repairs performed on this equipment may result in danger to the technician and machine operator and will invalidate your factory warranty. For your safety and to avoid Electrical Shock, please observe all safety notes and precautions detailed throughout this manual.

This Troubleshooting Guide is provided to help you locate and repair possible machine malfunctions. Simply follow the three-step procedure listed below.

#### **Step 1. LOCATE PROBLEM (SYMPTOM).**

Look under the column labeled “PROBLEM (SYMPTOMS)”. This column describes possible symptoms that the machine may exhibit. Find the listing that best describes the symptom that the machine is exhibiting.

#### **Step 2. POSSIBLE CAUSE.**

The second column labeled “POSSIBLE CAUSE” lists the obvious external possibilities that may contribute to the machine symptom.

#### **Step 3. RECOMMENDED COURSE OF ACTION**

This column provides a course of action for the Possible Cause, generally it states to contact your local Lincoln Authorized Field Service Facility.

If you do not understand or are unable to perform the Recommended Course of Action safely, contact your local Lincoln Authorized Field Service Facility.

### WARNING



#### **ELECTRIC SHOCK CAN KILL.**

- Turn off machine and disconnect input power by removing the plug from the receptacle switch before tightening, cleaning or replacing consumables.

### CAUTION

If for any reason you do not understand the test procedures or are unable to perform the tests/repairs safely, contact your **Local Lincoln Authorized Field Service Facility** for technical troubleshooting assistance before you proceed.

Observe all Safety Guidelines detailed throughout this manual

PROBLEMS (SYMPTOMS)	POSSIBLE CAUSE	RECOMMENDED COURSE OF ACTION
GREEN LED OFF, Fan not operating. No Input Power.	<ol style="list-style-type: none"> <li>1. Plug unit into 115V outlet.</li> <li>2. Reset Breaker.</li> </ol>	<p>If all recommended possible areas of misadjustment have been checked and the problem persists, <b>Contact your local Authorized Field Service Facility.</b></p>
GREEN LED ON, YELLOW Overtemperature / under pressure LED ON. Unit is overheated.	<ol style="list-style-type: none"> <li>1. Make sure the unit has not been operated beyond duty cycle limits.</li> <li>2. Air Flow obstructed.</li> </ol>	
GREEN LED ON, YELLOW Over temperature / under pressure LED blinks. No air flow in purge or pre-flow.	<ol style="list-style-type: none"> <li>1. Air not connected or pressure too low. Check source for at least 72.5 PSI (5 Bar) during purge or pre-flow, adjust air pressure to 65 PSI (4.5 Bar).</li> <li>2. Air filter or air line blocked, torch blocked. Replace filter cartridge. Check that air line and torch leads are free of twists and kinks.</li> </ol>	
GREEN LED ON, YELLOW Over temperature / under pressure LED OFF, no air flow when torch switch pressed.	<ol style="list-style-type: none"> <li>1. Shield cup not properly installed on torch. Check that shield cup is fully seated against torch.</li> <li>2. Faulty Torch Switch or Parts Assembly in torch holder. Refer to "Operations Section" (Torch Consumable Parts).</li> <li>3. Faulty Main PC Board Repair / Replace Power Supply.</li> </ol>	
GREEN LED ON, YELLOW Over temperature / under pressure LED OFF. Air flows, Pilot arc does not start.	<ol style="list-style-type: none"> <li>1. Faulty torch parts. Inspect torch parts and replace if necessary.</li> <li>2. Faulty main PC Board. Repair / replace.</li> </ol>	
Torch has pilot arc but does not cut.	<ol style="list-style-type: none"> <li>1. Work lead not connected. Make sure work lead is connected securely to bare metal.</li> <li>2. AC input power too low. Use shortest distance to breaker panel possible.</li> <li>3. Faulty Main PC Board. Repair/Replace.</li> </ol>	

 **CAUTION**

If for any reason you do not understand the test procedures or are unable to perform the tests/repairs safely, contact your **Local Lincoln Authorized Field Service Facility** for technical troubleshooting assistance before you proceed.

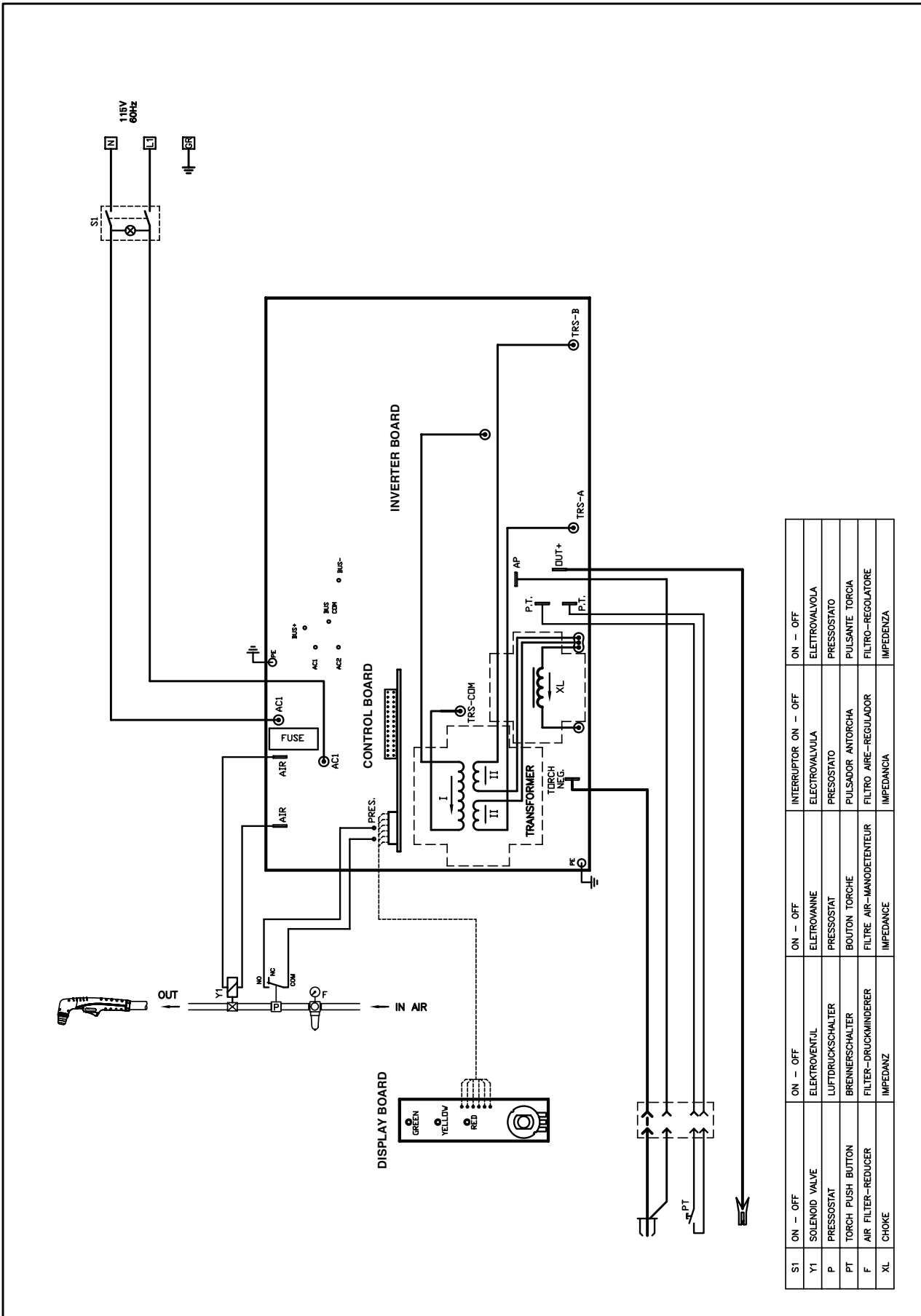

NOTE: This diagram is for reference only. It may not be accurate for all machines covered by this manual. The specific diagram for a particular code is pasted inside the machine on one of the enclosure panels. If the diagram is illegible, write to the Service Department for a replacement. Give the equipment code number.

# PARTS LIST FOR

# AUTOPRO™ 20

**This parts list is provided as an informative guide only.**

It was accurate at the time of printing. These pages are only updated on the Service Navigator DVD and in Lincoln Electric's official Parts Book (BK-34).

**When ordering parts, always refer to Lincoln Electric's official Parts Book (BK-34) for the latest pages.**

# GENERAL ASSEMBLY (Code 11971)

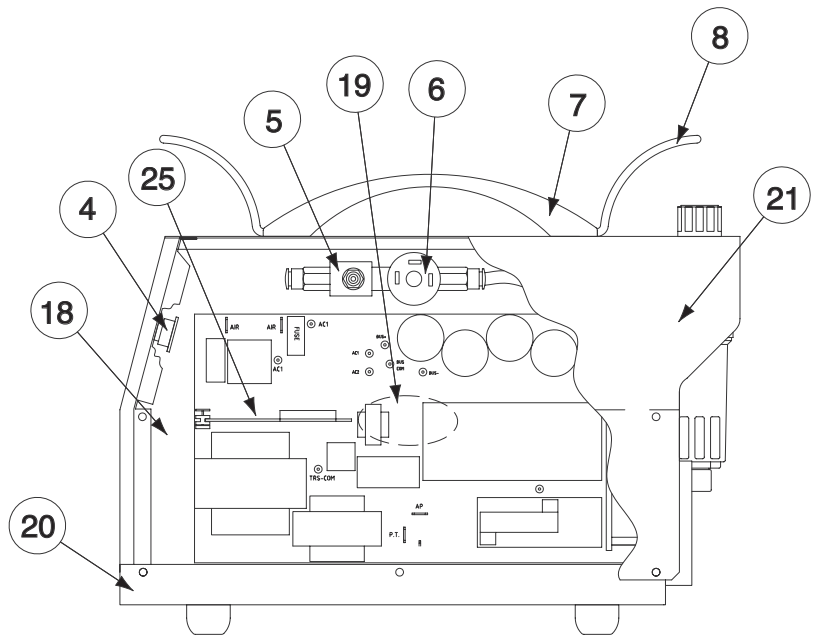
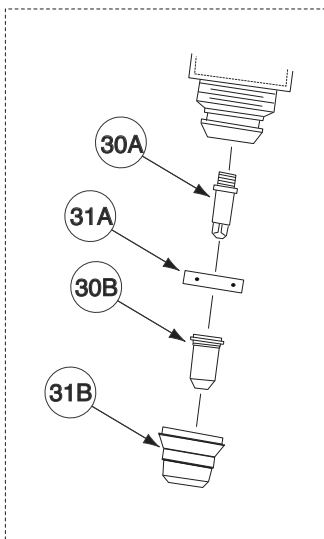
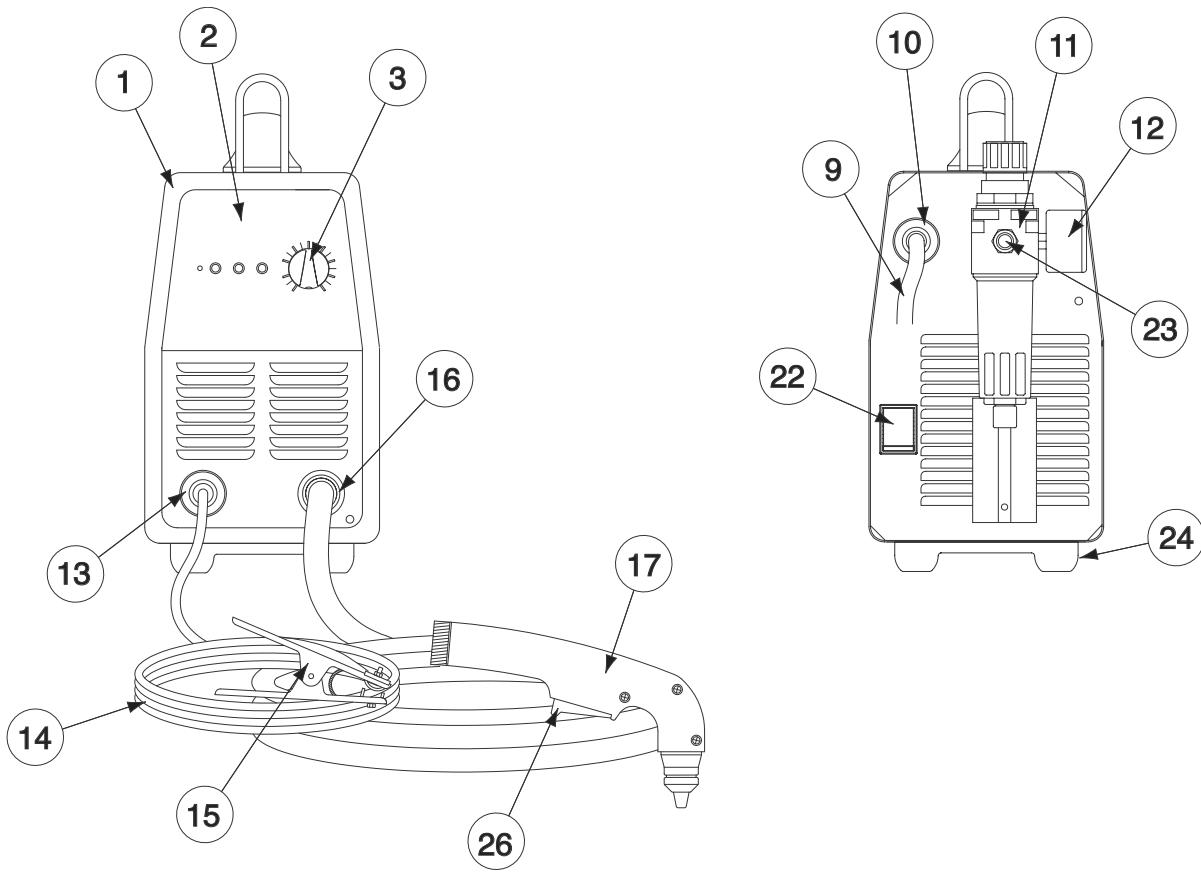



# Indicates a change this printing.

Use only the parts marked "x" in the column under the heading number called for in the model index page.

ITEM	DESCRIPTION	PART NO.	QTY.	1	2	3	4	5	6	7	8	9
1	Plastic Front Frame	S27185-1	1	X								
2	Front Panel with Nameplate	S29686-2	1	X								
3	Potentiometer Knob - Red	S27185-3	1	X								
4	Display P.C Board	S27185-4	1	X								
5	Solenoid Valve	S27185-5	1	X								
6	Air Pressure Switch	S27185-6	1	X								
7	Handle	S27185-7	1	X								
8	Cable Storage Flange	S27185-8	1	X								
9	Input Cord	S27185-9	1	X								
10	Cord Cable Clamp	S27185-10	1	X								
11	Air Filter	S27185-11	1	X								
12	Air Pressure Gauge	S27185-12	1	X								
13	Work Cable Clamp	S27185-13	1	X								
14	Work Cable	S27185-14	1	X								
15	Work Clamp	S27185-15	1	X								
16	Rubber Grommet (Strain Relief)	S27185-16	1	X								
17	PT-40 Torch	S27185-17	1	X								
18	Divider Panel	S27185-18	1	X								
19	Inverter P.C. Board	S27185-19	1	X								
20	Base with Splash Guard	S27185-20	1	X								
21	Wraparound with Side Decals	S29686-21	1	X								
22	Power Switch	S27185-22	1	X								
23	1/4"G - 1/4 NPT Gas Connector	S27185-23	1	X								
24	Feet	S27185-25	2	X								
25	Control P.C. Board	S27185-26	1	X								
26	Torch Trigger Micro-Switch	S27185-27	1	X								
27	Torch Head (Not Shown)	S27185-36	1	X								
28	Torch Handle w/Trigger (Not Shown)	S27185-37	1	X								
	<b>OPTIONS:</b>											
30	Consumable Spare Parts Kit, Includes:	KH652										
30A	Electrode	S27185-28	2									
30B	Nozzle	S27185-29	2									
31	Consumable Spare Parts Kit, Includes:	KH653										
31A	Air Diffuser Ring	S27185-30	1									
31B	Shield Cup	S27185-31	1									

#

# NOTES

---

# NOTES

---

			
<b>WARNING</b>	<ul style="list-style-type: none"> <li>Do not touch electrically live parts or electrode with skin or wet clothing.</li> <li>Insulate yourself from work and ground.</li> </ul>	<ul style="list-style-type: none"> <li>Keep flammable materials away.</li> </ul>	<ul style="list-style-type: none"> <li>Wear eye, ear and body protection.</li> </ul>
Spanish <b>AVISO DE PRECAUCION</b>	<ul style="list-style-type: none"> <li>No toque las partes o los electrodos bajo carga con la piel o ropa mojada.</li> <li>Aislese del trabajo y de la tierra.</li> </ul>	<ul style="list-style-type: none"> <li>Mantenga el material combustible fuera del área de trabajo.</li> </ul>	<ul style="list-style-type: none"> <li>Protéjase los ojos, los oídos y el cuerpo.</li> </ul>
French <b>ATTENTION</b>	<ul style="list-style-type: none"> <li>Ne laissez ni la peau ni des vêtements mouillés entrer en contact avec des pièces sous tension.</li> <li>Isolez-vous du travail et de la terre.</li> </ul>	<ul style="list-style-type: none"> <li>Gardez à l'écart de tout matériel inflammable.</li> </ul>	<ul style="list-style-type: none"> <li>Protégez vos yeux, vos oreilles et votre corps.</li> </ul>
German <b>WARNUNG</b>	<ul style="list-style-type: none"> <li>Berühren Sie keine stromführenden Teile oder Elektroden mit Ihrem Körper oder feuchter Kleidung!</li> <li>Isolieren Sie sich von den Elektroden und dem Erdboden!</li> </ul>	<ul style="list-style-type: none"> <li>Entfernen Sie brennbares Material!</li> </ul>	<ul style="list-style-type: none"> <li>Tragen Sie Augen-, Ohren- und Körperschutz!</li> </ul>
Portuguese <b>ATENÇÃO</b>	<ul style="list-style-type: none"> <li>Não toque partes elétricas e electrodos com a pele ou roupa molhada.</li> <li>Isole-se da peça e terra.</li> </ul>	<ul style="list-style-type: none"> <li>Mantenha inflamáveis bem guardados.</li> </ul>	<ul style="list-style-type: none"> <li>Use proteção para a vista, ouvido e corpo.</li> </ul>
Japanese <b>注意事項</b>	<ul style="list-style-type: none"> <li>通電中の電気部品、又は溶材にヒフやぬれた布で触れないこと。</li> <li>施工物やアースから身体が絶縁されている様にして下さい。</li> </ul>	<ul style="list-style-type: none"> <li>燃えやすいものの側での溶接作業は絶対にしてはなりません。</li> </ul>	<ul style="list-style-type: none"> <li>目、耳及び身体に保護具をして下さい。</li> </ul>
Chinese <b>警告</b>	<ul style="list-style-type: none"> <li>皮肤或湿衣物切勿接觸帶電部件及鐸條。</li> <li>使你自己與地面和工件絕緣。</li> </ul>	<ul style="list-style-type: none"> <li>把一切易燃物品移離工作場所。</li> </ul>	<ul style="list-style-type: none"> <li>佩戴眼、耳及身體勞動保護用具。</li> </ul>
Korean <b>위험</b>	<ul style="list-style-type: none"> <li>전도체나 용접봉을 젖은 헝겊 또는 피부로 절대 접촉치 마십시오.</li> <li>모재와 접지를 접촉치 마십시오.</li> </ul>	<ul style="list-style-type: none"> <li>인화성 물질을 접근 시키지 마시오.</li> </ul>	<ul style="list-style-type: none"> <li>눈, 귀와 몸에 보호장구를 착용하십시오.</li> </ul>
Arabic <b>تحذير</b>	<ul style="list-style-type: none"> <li>لا تلمس الاجزاء التي يسري فيها التيار الكهربائي أو الاكترود بجند الجسم أو بالملابس المبللة بالماء.</li> <li>ضع عازلا على جسمك خلال العمل.</li> </ul>	<ul style="list-style-type: none"> <li>ضع المواد القابلة للاشتعال في مكان بعيد.</li> </ul>	<ul style="list-style-type: none"> <li>ضع أدوات وملابس واقية على عينيك وأذنيك وجسمك.</li> </ul>

READ AND UNDERSTAND THE MANUFACTURER'S INSTRUCTION FOR THIS EQUIPMENT AND THE CONSUMABLES TO BE USED AND FOLLOW YOUR EMPLOYER'S SAFETY PRACTICES.

SE RECOMIENDA LEER Y ENTENDER LAS INSTRUCCIONES DEL FABRICANTE PARA EL USO DE ESTE EQUIPO Y LOS CONSUMIBLES QUE VA A UTILIZAR, SIGA LAS MEDIDAS DE SEGURIDAD DE SU SUPERVISOR.

LISEZ ET COMPRENEZ LES INSTRUCTIONS DU FABRICANT EN CE QUI REGARDE CET EQUIPMENT ET LES PRODUITS A ETRE EMPLOYES ET SUIVEZ LES PROCEDURES DE SECURITE DE VOTRE EMPLOYEUR.

LESEN SIE UND BEFOLGEN SIE DIE BETRIEBSANLEITUNG DER ANLAGE UND DEN ELEKTRODENEINSATZ DES HERSTELLERS. DIE UNFALLVERHÜTUNGSVORSCHRIFTEN DES ARBEITGEBERS SIND EBENFALLS ZU BEACHTEN.

			
<ul style="list-style-type: none"> <li>● Keep your head out of fumes.</li> <li>● Use ventilation or exhaust to remove fumes from breathing zone.</li> </ul>	<ul style="list-style-type: none"> <li>● Turn power off before servicing.</li> </ul>	<ul style="list-style-type: none"> <li>● Do not operate with panel open or guards off.</li> </ul>	<b>WARNING</b>
<ul style="list-style-type: none"> <li>● Los humos fuera de la zona de respiración.</li> <li>● Mantenga la cabeza fuera de los humos. Utilice ventilación o aspiración para gases.</li> </ul>	<ul style="list-style-type: none"> <li>● Desconectar el cable de alimentación de poder de la máquina antes de iniciar cualquier servicio.</li> </ul>	<ul style="list-style-type: none"> <li>● No operar con panel abierto o guardas quitadas.</li> </ul>	Spanish <b>AVISO DE PRECAUCION</b>
<ul style="list-style-type: none"> <li>● Gardez la tête à l'écart des fumées.</li> <li>● Utilisez un ventilateur ou un aspirateur pour ôter les fumées des zones de travail.</li> </ul>	<ul style="list-style-type: none"> <li>● Débranchez le courant avant l'entretien.</li> </ul>	<ul style="list-style-type: none"> <li>● N'opérez pas avec les panneaux ouverts ou avec les dispositifs de protection enlevés.</li> </ul>	French <b>ATTENTION</b>
<ul style="list-style-type: none"> <li>● Vermeiden Sie das Einatmen von Schweißrauch!</li> <li>● Sorgen Sie für gute Be- und Entlüftung des Arbeitsplatzes!</li> </ul>	<ul style="list-style-type: none"> <li>● Strom vor Wartungsarbeiten abschalten! (Netzstrom völlig öffnen; Maschine anhalten!)</li> </ul>	<ul style="list-style-type: none"> <li>● Anlage nie ohne Schutzgehäuse oder Innenschutzverkleidung in Betrieb setzen!</li> </ul>	German <b>WARNUNG</b>
<ul style="list-style-type: none"> <li>● Mantenha seu rosto da fumaça.</li> <li>● Use ventilação e exaustão para remover fumo da zona respiratória.</li> </ul>	<ul style="list-style-type: none"> <li>● Não opere com as tampas removidas.</li> <li>● Desligue a corrente antes de fazer serviço.</li> <li>● Não toque as partes elétricas nuas.</li> </ul>	<ul style="list-style-type: none"> <li>● Mantenha-se afastado das partes moventes.</li> <li>● Não opere com os painéis abertos ou guardas removidas.</li> </ul>	Portuguese <b>ATENÇÃO</b>
<ul style="list-style-type: none"> <li>● ヒュームから頭を離すようにして下さい。</li> <li>● 換気や排煙に十分留意して下さい。</li> </ul>	<ul style="list-style-type: none"> <li>● メンテナンス・サービスに取りかかる際には、まず電源スイッチを必ず切ってください。</li> </ul>	<ul style="list-style-type: none"> <li>● パネルやカバーを取り外したままで機械操作をしないで下さい。</li> </ul>	Japanese <b>注意事項</b>
<ul style="list-style-type: none"> <li>● 頭部遠離煙霧。</li> <li>● 在呼吸區使用通風或排風器除煙。</li> </ul>	<ul style="list-style-type: none"> <li>● 維修前切斷電源。</li> </ul>	<ul style="list-style-type: none"> <li>● 儀表板打開或沒有安全罩時不準作業。</li> </ul>	Chinese <b>警告</b>
<ul style="list-style-type: none"> <li>● 얼굴로부터 용접가스를 멀리하십시오.</li> <li>● 호흡지역으로부터 용접가스를 제거하기 위해 가스제거기나 통풍기를 사용하십시오.</li> </ul>	<ul style="list-style-type: none"> <li>● 보수전에 전원을 차단하십시오.</li> </ul>	<ul style="list-style-type: none"> <li>● 판넬이 열린 상태로 작동치 마십시오.</li> </ul>	Korean <b>위험</b>
<ul style="list-style-type: none"> <li>● ابعء رأسك بعيداً عن الدخان.</li> <li>● استعمل التهوية أو جهاز ضغط الدخان للخارج لكي تبعد الدخان عن المنطقة التي تتنفس فيها.</li> </ul>	<ul style="list-style-type: none"> <li>● اقطع التيار الكهربائي قبل القيام بأية صيانة.</li> </ul>	<ul style="list-style-type: none"> <li>● لا تشغيل هذا الجهاز اذا كانت الاغطية الحديدية الواقية ليست عليه.</li> </ul>	Arabic <b>تحذير</b>

**LEIA E COMPREENDA AS INSTRUÇÕES DO FABRICANTE PARA ESTE EQUIPAMENTO E AS PARTES DE USO, E SIGA AS PRÁTICAS DE SEGURANÇA DO EMPREGADOR.**

使う機械や溶材のメーカーの指示書をよく読み、まず理解して下さい。そして貴社の安全規定に従って下さい。

請詳細閱讀並理解製造廠提供的說明以及應該使用的銀焊材料，並請遵守貴方的有關勞動保護規定。

이 제품에 동봉된 작업지침서를 숙지하시고 귀사의 작업자 안전수칙을 준수하시기 바랍니다.

اقرأ بتمعن وافهم تعليمات المصنع المنتج لهذه المعدات والمواد قبل استعمالها واتبع تعليمات الوقاية لصاحب العمل.

---

**MARQUETTE**  
BY **LINCOLN**  
**ELECTRIC**

2345 Murphy Blvd. Gainesville, GA 30504 TEL: 866-236-0044