

Power Steering Products - Benefits & Features

Steering Gears

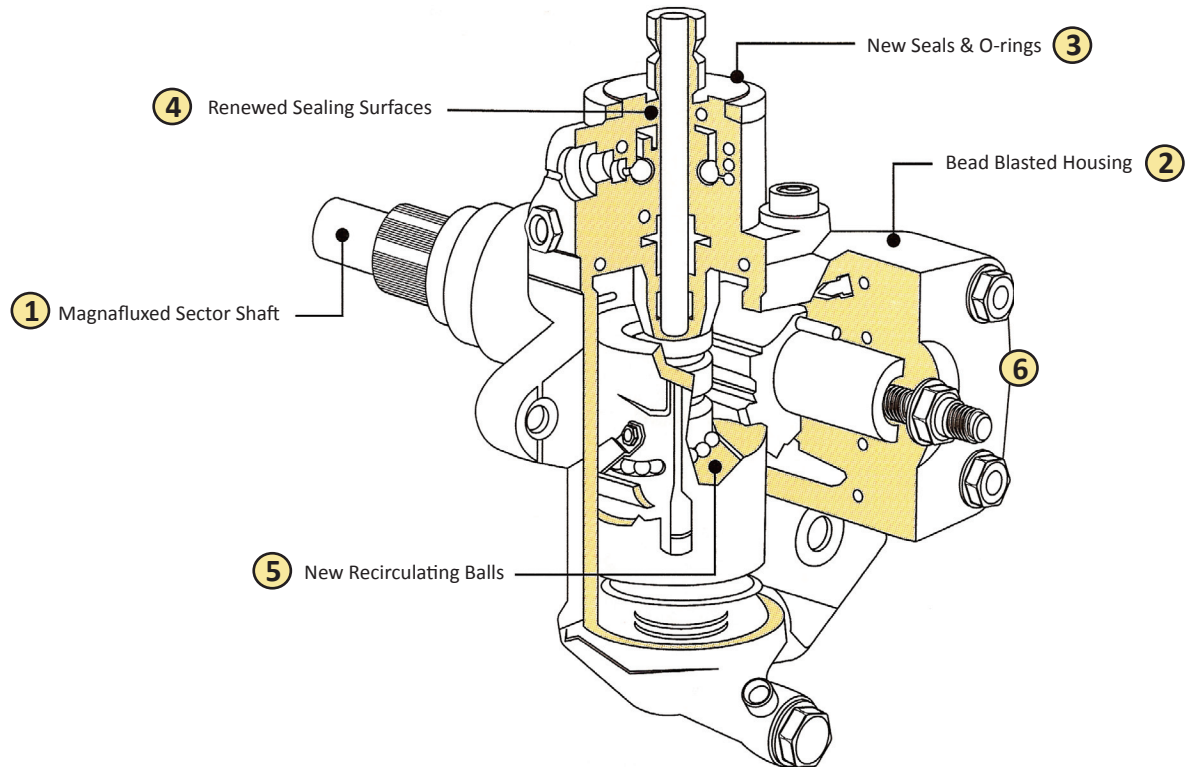

1

Feature:

Sector shafts are 100% magnafluxed.

Benefit:

Guarantees structural integrity by eliminating microscopic cracks to ensure long service life.

2

Feature:

Gear housings are inspected, bead blasted and rust proofed.

Benefit:

Eliminates corrosion and rust prior to reassembly ensuring long service life.

3

Feature:

All seals and O-rings are replaced with 100% new & OE-equivalent parts.

Benefit:

Ensures there will be no leaks, extends the life of the product and guarantees product reliability.

4

Feature:

Sealing surfaces are restored and polished.

Benefit:

Maximizes sealing and ensures long service life.

5

Feature:

Assembled units 100% functionally tested for leaks & steering performance prior to packaging.

Benefit:

Dependable reman rack and pinion steering you can trust.

6

Feature:

Units are 100% functionality tested for leaks and performance.

Benefit:

Guarantees performance and that units meet OE specifications.