

Engine Repair

PermaTorque® Head Gaskets

Construction of “No-Retorque” Gaskets

Fel-Pro PermaTorque® head gaskets are the most reliable no-retorque designs available on the market. They consist of four parts:

CORE

FACING

COATING

ARMOR

Are All “No-Retorque” Gaskets Alike?

No-retorque gaskets are NOT all alike. They vary significantly in the materials and designs used. Most manufacturers use lower-density facing materials. As a result, the gasket relaxes more, allowing torque loss.

By contrast, higher-density materials are used in the design of the Fel-Pro® line. The materials are further “densified” when they are applied to the core. Comparisons have shown that these gaskets retain torque significantly better than those of any competitor.

Using a “no-retorque” gasket that loses excessive torque can cause combustion or fluid leakage. Eventually, the gasket can fail and engine damage can occur.

The Core and Facing

The core of a true no-retorque gasket can be either solid or perforated steel, depending on the application. But the proper facing material attached to that core must be carefully chosen to ensure a no-retorque design.

Facing materials commonly used on these no-retorque gaskets include expanded graphite and reinforced rubber/fiber designs. These materials are dense enough to help maintain torque, yet compressible enough to conform to minor surface irregularities.

Coatings

NAPA Gaskets by Fel-Pro® are manufactured with several different surface coatings, which help seal minor surface imperfections and resist friction. Whether the specific coating is PTFE or silicone-based depends on the application.

Technicians also appreciate the way a gasket with an anti-stick coating comes off easily when the head is removed. Although the gasket can't be reused, the time saved in removing “stuck-on” gasket material from the cylinder head is considerable (especially with the extra care needed when working on aluminum heads).

Blue Stripe® – Perhaps the best-known gasket coating is this distinctive blue coating found on PermaTorque Blue Stripe gaskets. Trusted and respected by technicians everywhere, this striping ensures that the gasket is a genuine Fel-Pro gasket and is unequalled in its ability to seal traditional cast-iron engines.

Printoseal® – Today's lightweight, bi-metal engines have unique sealing requirements. Printoseal elastomeric sealing beads meet these demands. Applied around critical openings such as coolant and oil ports, they prevent leakage while compensating for uneven clamping force across the surface of the gasket.

Armors

Formed metal armors are needed to protect the gasket body at cylinder openings. They are the first line of defense against the intense heat and high pressure found in the combustion chamber.

Each armor is precision stamped, then formed to the gasket body to assure it performs as it should. Engineers specify different materials, ranging from tin plate to stainless steel, depending on the application. On high-performance or heavy-duty engines, a wire ring may be placed inside the armor for extra strength, to allow it to withstand the higher compression ratios and pressures associated with those engines.

PermaTorque® with Anti-Friction Coating

ANTI-FRICTION COATING → SEALS SMALL SURFACE

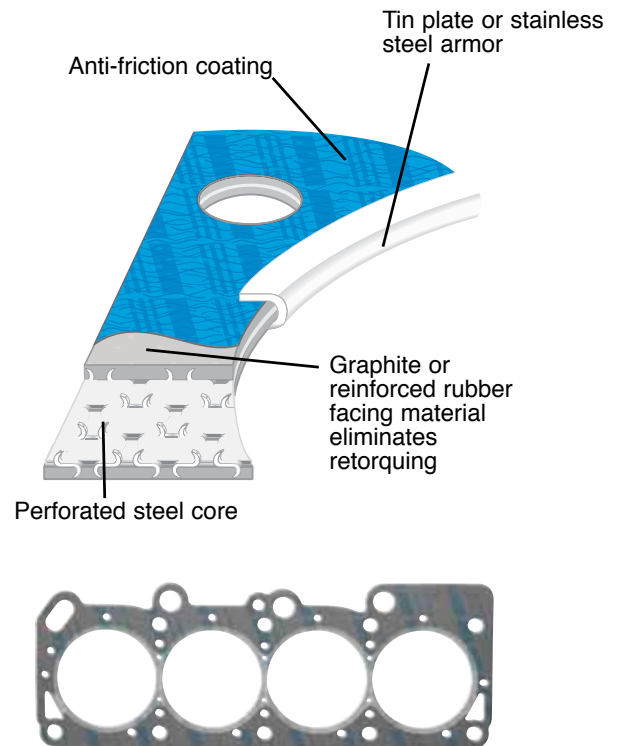
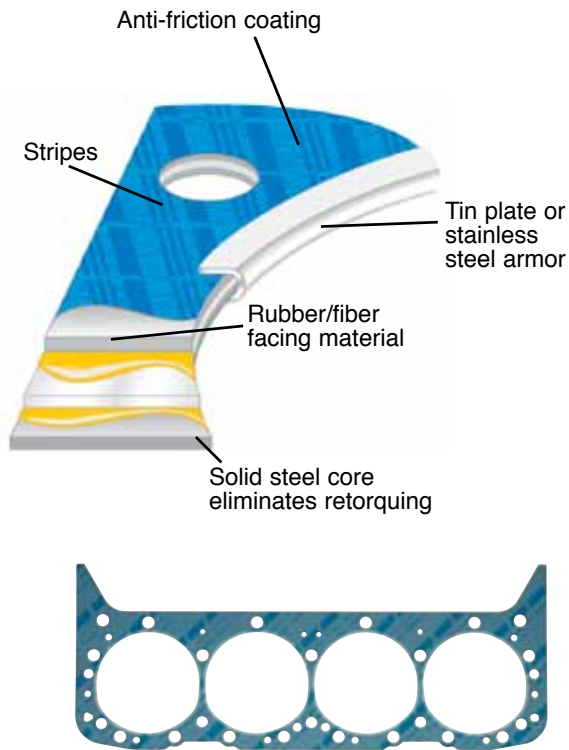

Fel-Pro PermaTorque® head gasket designs

PermaTorque Featuring Printoseal®

PRINTOSEAL ELASTOMERIC → SEALS "PROBLEM" → USED ON MANY ALUMINUM

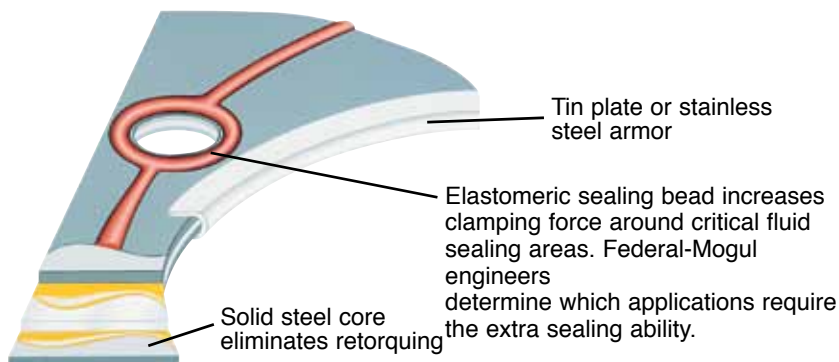

Fel-Pro PermaTorque® featuring Printoseal® head gasket design