

INSTRUCTION SHEET

OFF VEHICLE CARBURETOR SERVICE

HITACHI-MODEL DCP306-11 THRU 27

50-621-3

SUBARU

GENERAL EXPLODED VIEW

THE GENERAL DESIGN AND PARTS SHOWN WILL VARY TO INDIVIDUAL UNITS COVERED ON THIS INSTRUCTION SHEET.

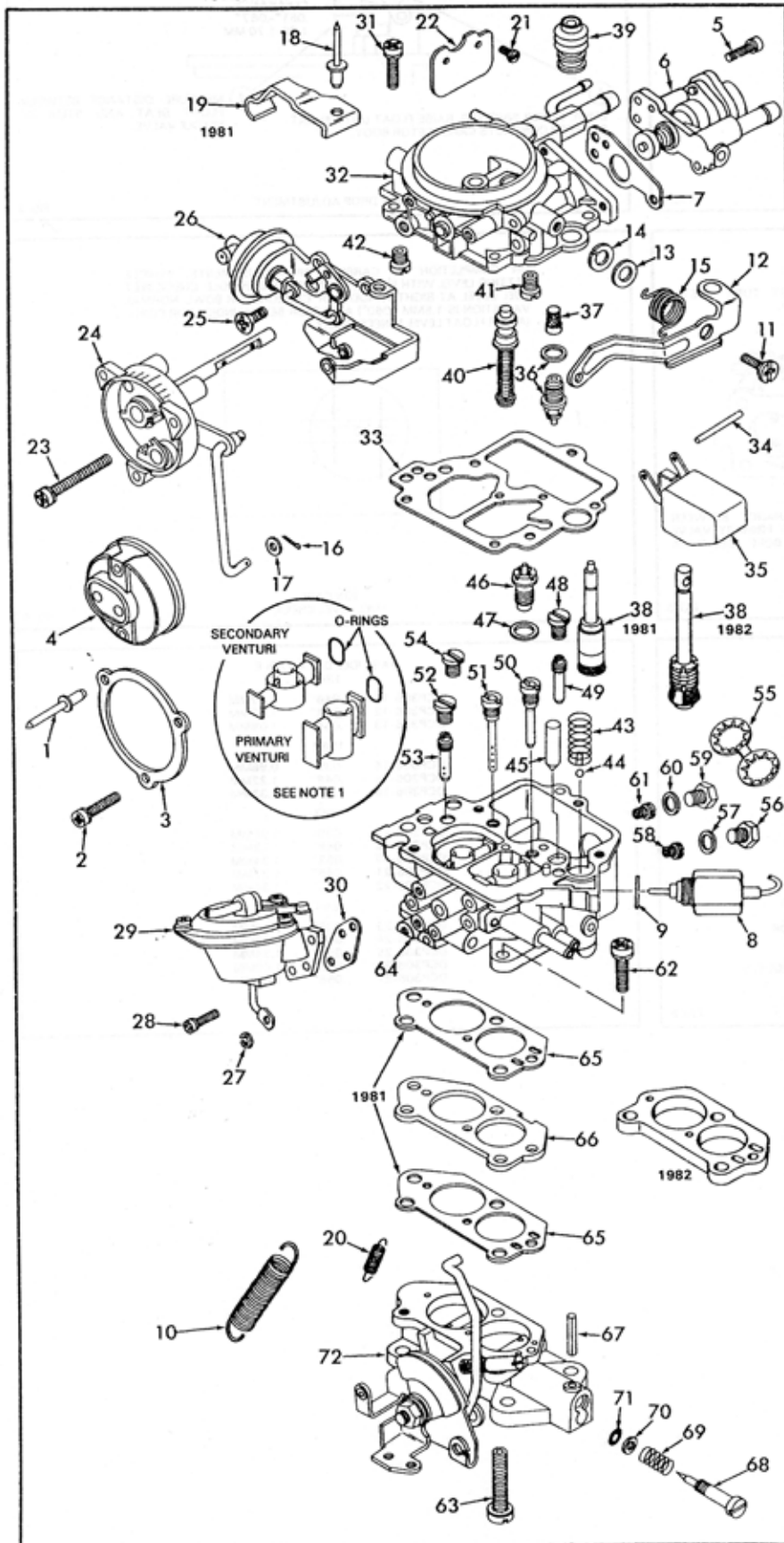

DISASSEMBLY

USE THE EXPLODED VIEW AS A GUIDE. THE NUMERICAL SEQUENCE MAY GENERALLY BE FOLLOWED TO DISASSEMBLE UNIT FAR ENOUGH TO PERMIT CLEANING AND INSPECTION. CAUTION: ORIGINALLY SCREWS HAVE LOCK TIGHT APPLIED TO THEM, TAKE EXTRA CARE IN REMOVING THEM. USE PROPER TOOLS. DRILL OR CUT OFF POP RIVET HEADS TO REMOVE CHOKE COVER AND CHOKE LEVER COVER. REMOVE STAKING FROM AIR HORN FOR EASY REMOVAL OF POWER PISTON ASSY. NOTE SIZES OF ALL JETS AND THEIR LOCATION FOR PROPER ASSEMBLY. RECORD SIZES BELOW.

NOTE: 1. IF NECESSARY TO REMOVE VENTURI'S, REMOVE STAKING LOCKING VENTURI LOCK SCREW AND LOOSEN SCREW. VENTURI CAN BE REMOVED TO INSTALL A NEW O-RING SEAL. INSTALL A NEW O-RING THEN HOLDING VENTURI FIRMLY IN PLACE, TIGHTEN LOCK SCREW. (RESTATE)

NOMENCLATURE

REF. NO.	REF. NO.
1. POP RIVET (2)-CHOKE COVER RETAINER	35. FLOAT & LEVER ASSY.
2. SCREW & LOCKWASHER-CHOKE COVER RETAINER	36. NEEDLE, SEAT & GASKET ASSY.
3. RETAINER-CHOKE COVER	37. SCREEN-NEEDLE SEAT
4. CHOKE COVER ASSY.	38. PUMP ASSY.
5. SCREW & LOCKWASHER (3)-BOWL VENT ASSY.	39. BOOT-PUMP STEM
6. BOWL VENT ASSY.	40. PISTON ASSY.-POWER VALVE
7. GASKET-BOWL VENT ASSY.	41. JET-PRIMARY SLOW AIR BLEED
8. SOLENOID SWITCH-ANTI DIESELING	42. JET-SECONDARY SLOW AIR BLEED
9. GASKET-SOLENOID SWITCH	43. SPRING-PUMP RETURN
10. SPRING-THROTTLE RETURN	44. BALL-PUMP INTAKE (NYLON)
11. SCREW STUD-PUMP LEVER	45. NEEDLE-PUMP DISC.
12. LEVER-PUMP	46. POWER VALVE ASSY.
13. FLATWASHER-LEVER SCREW	47. GASKET-POWER VALVE
14. LOCKWASHER-LEVER SCREW	48. PLUG-PRI SLOW JET
15. SPRING-PUMP LEVER	49. JET-PRI SLOW
16. COTTER PIN-CHOKE ROD (LOWER END)	50. JET-PRI MAIN AIR BLEED
17. WASHER-CHOKE ROD	51. JET-SEC. MAIN AIR BLEED
18. POP RIVET-COVER	52. PLUG-SEC. SLOW JET
19. COVER-CHOKE LEVER	53. JET-SEC. SLOW
20. SPRING-SECONDARY RETURN	54. PLUG-PASSAGE
21. SCREW (2)-CHOKE VALVE	55. RETAINER-MAIN JET PLUGS
22. VALVE-CHOKE	56. PLUG-PRI MAIN JET
23. SCREW & LOCKWASHER (2)-CHOKE HOUSING	57. GASKET-PLUG
24. CHOKE HOUSING & SHAFT ASSY.	58. JET-PRI MAIN
25. SCREW-CHOKE PULL OFF BRACKET	59. PLUG-SEC. MAIN JET
26. CHOKE PULL OFF & BRACKET ASSY.	60. GASKET-PLUG
27. RETAINER-SECONDARY DIAPHRAGM ROD	61. JET-SEC. MAIN
28. SCREW & LOCKWASHER (3)-SEC. DIAPHRAGM ASSY.	62. SCREW & LOCKWASHER (2)-THROTTLE BODY
29. SECONDARY DIAPHRAGM ASSY.	63. SCREW & LOCKWASHER (1)-THROTTLE BODY
30. GASKET-SEC. DIAPHRAGM ASSY.	64. BOWL ASSY.
31. SCREW & LOCKWASHER (5)-BOWL COVER	65. GASKET (2)-THROTTLE BODY INSULATOR
32. BOWL COVER ASSY.	66. INSULATOR-THROTTLE BODY
33. GASKET-BOWL COVER	67. SPRING PIN-IDLE ADJ. NEEDLE (WHEN USED)
34. PIN-FLOAT	68. NEEDLE-IDLE ADJUSTING
	69. SPRING-IDLE ADJ. NEEDLE
	70. WASHER-IDLE NEEDLE SEAL
	71. SEAL-IDLE NEEDLE
	72. THROTTLE BODY ASSY.

CLEANING

CLEANING MUST BE DONE WITH CARBURETOR DISASSEMBLED. SOAK PARTS LONG ENOUGH TO SOFTEN AND REMOVE ALL FOREIGN MATERIAL. USE A CARBURETOR CLEANING SOLVENT. MAKE CERTAIN THE THROTTLE BODY IS FREE OF ALL CARBON DEPOSITS. WASH OFF IN SUITABLE SOLVENT. BLOW OUT ALL PASSAGES IN CASTINGS WITH COMPRESSED AIR AND CHECK CAREFULLY TO INSURE THOROUGH CLEANING OF OBSCURE AREAS. CAUTION: BE VERY CAREFUL NOT TO LEAVE FUEL BOWL ASSY. (64) IN CLEANING SOLVENT TOO LONG BECAUSE OF THE GLASS WINDOW SEAL WHICH IS NOT REPLACEABLE. DO NOT SOAK ASSEMBLIES WITH ATTACHED PLASTIC PARTS FOR A LONG PERIOD OF TIME. DO NOT SOAK PARTS SUCH AS (4), (6), (8), (26), (29), (35), (38), (39), (49) IN ANY TYPE OF CLEANING SOLVENTS.

REASSEMBLY

REASSEMBLE IN REVERSE ORDER OF DISASSEMBLY. NOTE SPECIAL INSTRUCTIONS AND FOLLOW NUMERICAL OUTLINE IN MAKING ADJUSTMENTS NECESSARY FOR CARBURETOR BEING SERVICED.

SPECIAL INSTRUCTIONS

IDLE ADJUSTING NEEDLE (68)-TURN NEEDLE IN UNTIL LIGHTLY SEATED. THEN BACK OUT 4 TURNS.

PUMP RETURN SPRING (43)-INSTALL WITH CROSS WIRE TO THE BOTTOM OF PUMP CYLINDER.

1981 PUMP CUP SERVICE INSTRUCTIONS

PLACE PUMP STEM BETWEEN WOODEN BLOCKS AND CLAMP IN VISE. TAKE TWO SMALL BLADE SCREW DRIVERS AND INSERT UNDER CUP AND CAREFULLY PRY UP REMOVING CUP, INSERT WASHER AND SCREEN.

TO REPLACE: INSTALL CUP THEN PLACE INSERT WASHER AND SCREEN ASSEMBLY ON STEM. USING A 5/16" DIAMETER FLAT PUNCH AND HAMMER, LIGHTLY TAP ASSEMBLY IN PLACE. CAUTION: CUP SHOULD BE HELD FIRMLY IN PLACE. DO NOT OVER TIGHTEN.

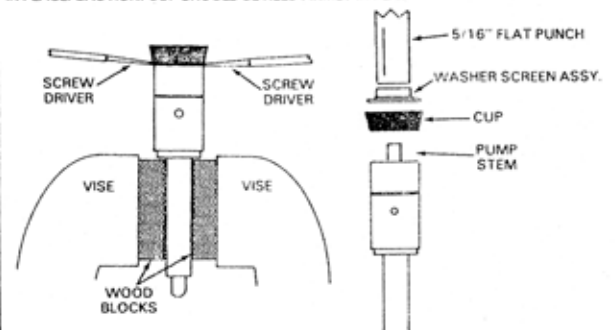

ADJUSTMENTS

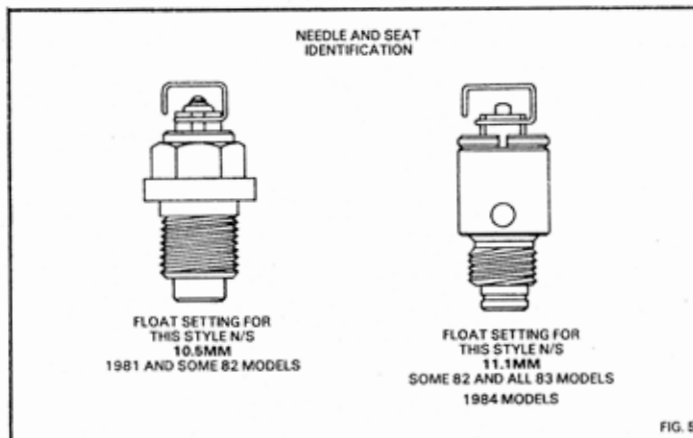
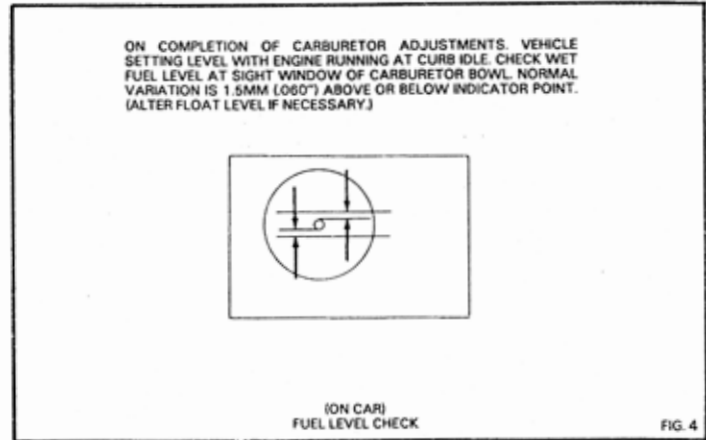
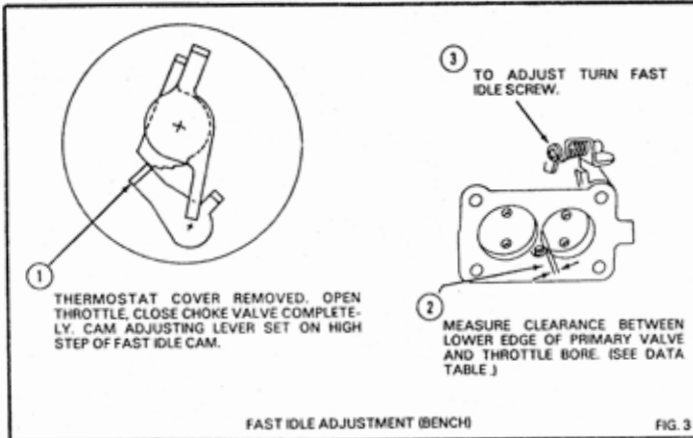
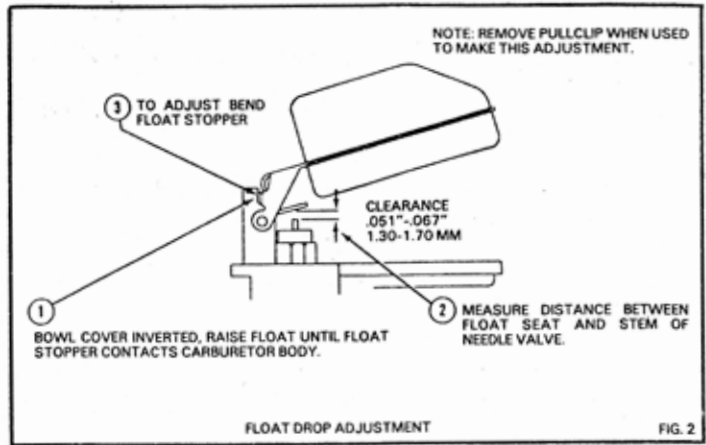
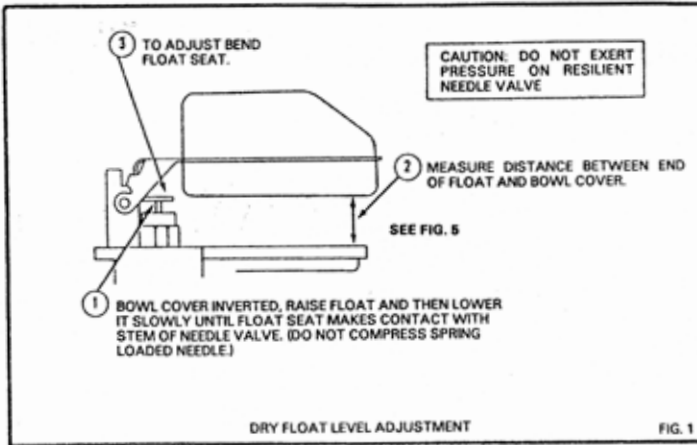

FAST IDLE DATA TABLE		
1981		
DCP306-11	.046"	1.17MM
DCP306-12	.054"	1.38MM
DCP306-13	.054"	1.38MM
1982		
DCP306-14	.039"	0.98MM
DCP306-15	.048"	1.22MM
DCP306-16	.052"	1.33MM
1983		
DCP306-17	.039"	0.98MM
DCP306-18	.048"	1.22MM
DCP306-19	.052"	1.34MM
DCP306-21	.048"	1.22MM
DCP306-22	.052"	1.34MM
1984		
DCP306-23	.039"	0.98MM
DCP306-24	.048"	1.22MM
DCP306-25	.052"	1.34MM
DCP306-26	.055"	1.40MM
DCP306-27	.056"	1.43MM